

## 阅读申明

- 1.本站收集的数据手册和产品资料都来自互联网，版权归原作者所有。如读者和版权方有任何异议请及时告之，我们将妥善解决。
- 2.本站提供的中文数据手册是英文数据手册的中文翻译，其目的是协助用户阅读，该译文无法自动跟随原稿更新，同时也可能存在翻译上的不当。建议读者以英文原稿为参考以便获得更精准的信息。
- 3.本站提供的产品资料，来自厂商的技术支持或者使用者的心得体会等，其内容可能存在描述上的差异，建议读者做出适当判断。
- 4.如需与我们联系，请发邮件到marketing@iczoom.com，主题请标有“数据手册”字样。

## Read Statement

1. The datasheets and other product information on the site are all from network reference or other public materials, and the copyright belongs to the original author and original published source. If readers and copyright owners have any objections, please contact us and we will deal with it in a timely manner.
2. The Chinese datasheets provided on the website is a Chinese translation of the English datasheets. Its purpose is for reader's learning exchange only and do not involve commercial purposes. The translation cannot be automatically updated with the original manuscript, and there may also be improper translations. Readers are advised to use the English manuscript as a reference for more accurate information.
3. All product information provided on the website refer to solutions from manufacturers' technical support or users the contents may have differences in description, and readers are advised to take the original article as the standard.
4. If you have any questions, please contact us at marketing@iczoom.com and mark the subject with "Datasheets" .

## ICs for use with 3rd Overtone Crystal Oscillators

### GENERAL DESCRIPTION

The XC2163 series are high frequency, low current consumption CMOS ICs with built-in crystal oscillator and divider circuits. Output is selectable from any one of the following values for  $f_0$ :  $f_0/1$ ,  $f_0/2$ ,  $f_0/4$ ,  $f_0/8$ .

With oscillation capacitors and a feedback resistors built-in, it is possible to configure a stable 3rd overtone oscillator using only an external crystal oscillator.

Also available is an external oscillation capacitor/external oscillation feedback resistor type, which makes oscillation frequency control possible.

### APPLICATIONS

- Crystal Oscillation Modules
- Computer, DSP Clocks
- Communication Equipment
- Various System Clocks

### FEATURES

- Oscillation Frequency** : 40MHz ~ 125MHz  
(Rf, Cg, Cd internal; 5.0V)
- (3rd Overtone)** : 57MHz ~ 125MHz  
(Rf, Cg, Cd internal; 3.3V)
- : 20MHz ~ 125MHz  
(Rf, Cg, Cd external)
- Divider Ratio** : Selectable from  $f_0/1$ ,  $f_0/2$ ,  $f_0/4$ ,  $f_0/8$ .
- Output** : 3-State
- Operating Voltage Range** : 3.3V  $\pm$  10%, 5.0V  $\pm$  10%
- Low Current Consumption** : Stand-by function included \*

#### CMOS

**Built-in Oscillation Capacitor**

**Built-in Oscillation Feedback Resistor**

**Package** : SOT-26

**Environmentally Friendly** : EU RoHS Compliant, Pb Free

\* Oscillation continues in stand-by mode

### PIN CONFIGURATION

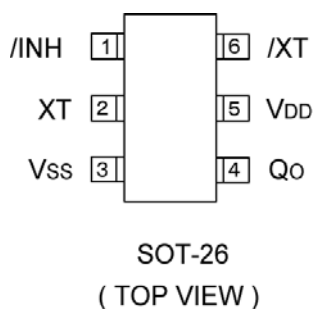

### PIN ASSIGNMENT

PIN NUMBER	PIN NAME	FUNCTION
1	/INH	Stand-by Control*
2	XT	Crystal Oscillator Connection (Input)
3	Vss	GND
4	Q0	Clock Output
5	VDD	Power Supply
6	/XT	Crystal Oscillator Connection (Output)

\* Stand-by control pin has a pull-up resistor built-in.

### /INH, Q0 PIN FUNCTION

/INH	"H" or OPEN	"L"(Stand-by)
Q0	Divider Output	High Impedance

"H" = High Level

"L" = Low Level

## PRODUCT CLASSIFICATION

### Ordering Information

XC2163 \_\_\_\_\_ - (\*1)

DESIGNATOR	DESCRIPTION	SYMBOL	DESCRIPTION
	Divider Ratio	C	: f0/1
		D	: f0/2
		E	: f0/4
		F	: f0/8
	Output Capacity	5	: 10TTL
	Duty Level	1	: CMOS (V <sub>DD</sub> /2) *TTL : 20MHz to 37MHz
	Frequency Range & R <sub>f</sub> , C <sub>g</sub> , C <sub>d</sub> Values	Z	: External type (refer to table 1)
		A ~ L	: Built-in type (refer to table 2)
-	Packages Taping Type (*2)	MR-G	: SOT-26

(\*1) The "-G" suffix indicates that the products are Halogen and Antimony free as well as being fully RoHS compliant.

(\*2) The device orientation is fixed in its embossed tape pocket. For reverse orientation, please contact your local Torex sales office or representative. (Standard orientation: R- , Reverse orientation: L- )

Table 1: Frequency for External Type

SYMBOL	5.0V TYPE			3.3V TYPE		
	FREQUENCY RANGE	R <sub>f</sub>	C <sub>g</sub> /C <sub>d</sub>	FREQUENCY RANGE	R <sub>f</sub>	C <sub>g</sub> /C <sub>d</sub>
Z	108MHz ~ 125MHz	1.6k	10pF	108MHz ~ 125MHz	3.9k	4pF
	93MHz ~ 110MHz	2.4k	10pF	95MHz ~ 110MHz	2.4k	7pF
	80MHz ~ 95MHz	2.4k	12pF	80MHz ~ 97MHz	2.7k	8pF
	68MHz ~ 83MHz	2.4k	15pF	68MHz ~ 83MHz	2.7k	10pF
	55MHz ~ 70MHz	3.3k	15pF	58MHz ~ 70MHz	3.9k	10pF
	45MHz ~ 57MHz	3.3k	20pF	50MHz ~ 60MHz	3.9k	12pF
	35MHz ~ 47MHz	3.6k	24pF	40MHz ~ 52MHz	2.4k	20pF
	28MHz ~ 37MHz	4.7k	27pF	33MHz ~ 42MHz	3.6k	20pF
	24MHz ~ 30MHz	5.6k	30pF	28MHz ~ 35MHz	3.6k	24pF
	20MHz ~ 26MHz	6.8k	33pF	24MHz ~ 30MHz	3.9k	27pF
-	-	-	20MHz ~ 26MHz	3.9k	33pF	

Note: We recommend that a damping resistor R<sub>d</sub> be added between the /XT pin & the crystal oscillator pin in order to safeguard the crystal oscillator and improve oscillation stability.

Table 2: Frequency for Built-In Type

SYMBOL	5.0V TYPE			3.3V TYPE		
	FREQUENCY RANGE	R <sub>f</sub>	C <sub>g</sub> /C <sub>d</sub>	FREQUENCY RANGE	R <sub>f</sub>	C <sub>g</sub> /C <sub>d</sub>
A	-	-	-	108MHz ~ 125MHz	1.5k	5.5pF
B	-	-	-	93MHz ~ 110MHz	1.7k	6.5pF
C	108MHz ~ 125MHz	2.2k	5.5pF	80MHz ~ 95MHz	2.2k	5.5pF
D	95MHz ~ 110MHz	2.4k	6.5pF	72MHz ~ 83MHz	2.4k	6.5pF
E	80MHz ~ 97MHz	3.2k	6.5pF	65MHz ~ 75MHz	3.2k	6.5pF
F	68MHz ~ 83MHz	3.7k	6.5pF	57MHz ~ 67MHz	3.7k	6.5pF
H	55MHz ~ 70MHz	4.9k	7.6pF	-	-	-
K	45MHz ~ 57MHz	5.5k	11.0pF	-	-	-
L	40MHz ~ 48MHz	6.5k	11.0pF	-	-	-

## BLOCK DIAGRAMS

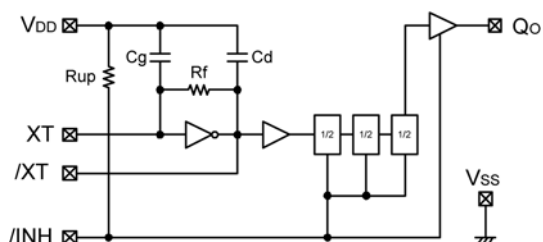

① Built-in oscillation capacitors, oscillation feedback resistor

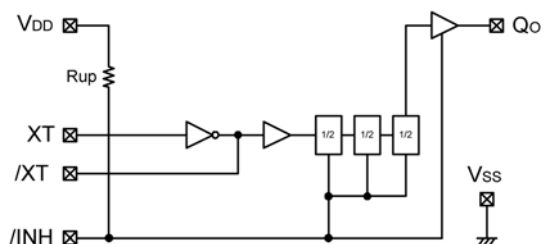

② External oscillation capacitors, oscillation feedback resistor

## ABSOLUTE MAXIMUM RATINGS

PARAMETER	SYMBOL	CONDITIONS	UNITS
Supply Voltage	VDD	VSS-0.3 ~ VSS+7.0	V
Input Voltage	VIN	VSS-0.3 ~ VDD+0.3	V
Power Dissipation	Pd	250 *	mW
Operating Temperature Range	Topr	-30 ~ +80	
Storage Temperature Range	Tstg	-55 ~ +125	

\* When implemented on a glass epoxy PCB.

## ELECTRICAL CHARACTERISTICS

XC2163C51AMR

Fosc=108MHz~125MHz

(Unless otherwise stated, VDD=3.3V, Ta=25 )

PARAMETER	SYMBOL	CONDITIONS	STANDARD VALUE			UNITS
			MIN.	TYP.	MAX.	
Operating Voltage	VDD		2.97	-	3.63	V
'H' Level Input Voltage	VIH	/INH pin	2.4	-	-	V
'L' Level Input Voltage	VIL	/INH pin		-	0.4	V
'H' Level Output Voltage	VOH	Qo pin, VDD = 2.97V, IOH = 8mA	2.2	2.4	-	V
'L' Level Output Voltage	VOL	Qo pin, VDD = 2.97V, IOL = 8mA	-	0.3	0.4	V
Supply Current 1	Idd1	/INH = OPEN, CL = 15pF, f = 125MHz	-	18	-	mA
Supply Current 2	Idd2	/INH = 'L', f = 125MHz	-	5	-	mA
Input Pull-Up Resistance 1	Rup1	/INH = 'L'	1.0	2.0	4.0	M
Input Pull-Up Resistance 2	Rup2	/INH = 0.7VDD	35	70	140	k
Internal Oscillation Capacity	Cg	R&D Value	-	5.5	-	pF
	Cd	R&D Value	-	5.5	-	pF
Internal Oscillation Feedback Resistance	Rf		-	1.5	-	k
Output Off Leak Current	Ioz	Qo pin, /INH = 'L'	-	-	10	μA

Note) R&G value

XC2163C51BMR

Fosc=93MHz~110MHz

(Unless otherwise stated, VDD=3.3V, No load, Ta=25 )

PARAMETER	SYMBOL	CONDITIONS	STANDARD VALUE			UNITS
			MIN.	TYP.	MAX.	
Operating Voltage	VDD		2.97	-	3.63	V
'H' Level Input Voltage	VIH	/INH pin	2.4	-	-	V
'L' Level Input Voltage	VIL	/INH pin	-	-	0.4	V
'H' Level Output Voltage	VOH	Qo pin, VDD = 2.97V, IOH = 8mA	2.2	2.4	-	V
'L' Level Output Voltage	VOL	Qo pin, VDD = 2.97V, IOL = 8mA	-	0.3	0.4	V
Supply Current 1	Idd1	/INH = OPEN, CL = 15pF, f = 110MHz	-	15	-	mA
Supply Current 2	Idd2	/INH = 'L', f = 110MHz	-	5	-	mA
Input Pull-Up Resistance 1	Rup1	/INH = 'L'	1.0	2.0	4.0	M
Input Pull-Up Resistance 2	Rup2	/INH = 0.7VDD	35	70	140	k
Internal Oscillation Capacity	Cg	R&D Value	-	6.5	-	pF
	Cd	R&D Value	-	6.5	-	pF
Internal Oscillation Feedback Resistance	Rf		-	1.7	-	k
Output Off Leak Current	Ioz	Qo pin, /INH = 'L'	-	-	10	μA

## SWITCHING CHARACTERISTICS

XC2163C51AMR/XC2163C51BMR

CMOS DUTY:VDD=3.3V, Ta=25

PARAMETER	SYMBOL	CONDITIONS	STANDARD VALUE			UNITS	
			MIN.	TYP.	MAX.		
Output Rise Time	tr	CL=15pF, 0.1VDD 0.9VDD	-	1.5	-	ns	
Output Fall Time	tf	CL=15pF, 0.9VDD 0.1VDD	-	1.5	-	ns	
Output Duty Cycle	DUTY	C51A	0.5VDD, CL=15pF, f=125MHz	45	-	55	%
		C51B	0.5VDD, CL=15pF, f=110MHz				
Output Disable Delay Time	tplz	CL=15pF	-	-	100	ns	

## ELECTRICAL CHARACTERISTICS (Continued)

XC2163C51ZMR

Fosc = 108MHz to 125MHz; Rf = 1.6k , Cg = Cd = 10pF external

(Unless otherwise stated, VDD=5.0V, Ta=25 )

PARAMETER	SYMBOL	CONDITIONS	STANDARD VALUE			UNITS
			MIN.	TYP.	MAX.	
Operating Voltage	VDD		4.5	-	5.5	V
'H' Level Input Voltage	VIH	/INH pin	2.4	-	-	V
'L' Level Input Voltage	VIL	/INH pin	-	-	0.4	V
'H' Level Output Voltage	VOH	Qo pin, VDD = 4.5V, IOH = -16mA	3.9	4.2	-	V
'L' Level Output Voltage	VOL	Qo pin, VDD = 4.5V, IOL = 16mA	-	0.3	0.4	V
Supply Current 1	IDD1	/INH = OPEN, CL = 15pF, f = 120MHz	-	31	-	mA
Supply Current 2	IDD2	/INH = 'L', f = 120MHz	-	14	-	mA
Input Pull-Up Resistance 1	Rup1	/INH = 'L'	0.5	1.0	2.0	M
Input Pull-Up Resistance 2	Rup2	/INH = 0.7VDD	25	50	100	k
Output Off Leak Current	Ioz	Qo pin, /INH = 'L'	-	-	10	μA

## SWITCHING CHARACTERISTICS

XC2163C51ZMR

CMOS DUTY : VDD=5.0V, Ta=25

PARAMETER	SYMBOL	CONDITIONS	STANDARD VALUE			UNITS
			MIN.	TYP.	MAX.	
Output Rise Time	tr	CL=15pF, 0.1VDD 0.9VDD	-	1.5	-	ns
Output Fall Time	tf	CL=15pF, 0.9VDD 0.1VDD	-	1.5	-	ns
Output Duty Cycle	DUTY	0.5VDD, CL=15pF, f=120MHz	45	-	55	%
Output Disable Delay Time	tpLz	CL=15pF	-	-	100	ns
Output Enable Delay Time	tpzL	CL=15pF	-	-	100	ns

The contents can be changed without advance notice.

## ELECTRICAL CHARACTERISTICS (Continued)

XC2163C51ZMR

Fosc= 108MHz to 125MHz : Rf = 3.9k , Cg = Cd = 4pF external

(Unless otherwise stated, VDD=3.3V, Ta=25 )

PARAMETER	SYMBOL	CONDITIONS	STANDARD VALUE			UNITS
			MIN.	TYP.	MAX.	
Operating Voltage	VDD		2.97	-	3.63	V
'H' Level Input Voltage	VIH	/INH pin	2.4	-	-	V
'L' Level Input Voltage	VIL	/INH pin	-	-	0.4	V
'H' Level Output Voltage	VOH	Qo pin, VDD = 2.97V, IOH = -8mA	2.2	2.4	-	V
'L' Level Output Voltage	VOL	Qo pin, VDD = 2.97V, IOL = 8mA	-	0.3	0.4	V
Supply Current 1	IDD1	/INH = OPEN, CL = 15pF, f = 120MHz	-	15	-	mA
Supply Current 2	IDD2	/INH = 'L', f = 100MHz	-	4	-	mA
Input Pull-Up Resistance 1	Rup1	/INH = 'L'	2.0	4.0	6.0	M
Input Pull-Up Resistance 2	Rup2	/INH = 0.7VDD	70	140	250	k
Output Off Leak Current	Ioz	Qo pin, /INH = 'L'	-	-	10	μA

## SWITCHING CHARACTERISTICS

XC2163C51ZMR

CMOS DUTY : VDD=3.3V, Ta=25

PARAMETER	SYMBOL	CONDITIONS	STANDARD VALUE			UNITS
			MIN.	TYP.	MAX.	
Output Rise Time	tr	CL=15pF, 0.1VDD ~ 0.9VDD	-	1.5	-	ns
Output Fall Time	tf	CL=15pF, 0.9VDD ~ 0.1VDD	-	1.5	-	ns
Output Duty Cycle	DUTY	0.5VDD, CL=15pF, f=120MHz	45	-	55	%
Output Disable Delay Time	tpLz	CL=15pF	-	-	100	ns
Output Enable Delay Time	tpzL	CL=15pF	-	-	100	ns

The contents can be changed without advance notice.

## SWITCHING CHARACTERISTICS MEASUREMENT WAVEFORMS

### (1) Switching Time

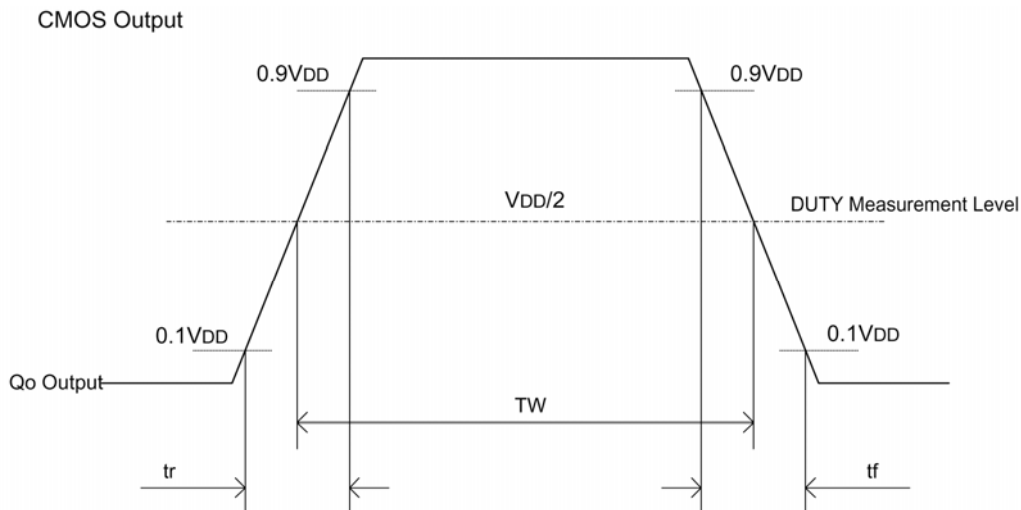

### (2) Output Waveform Symmetry

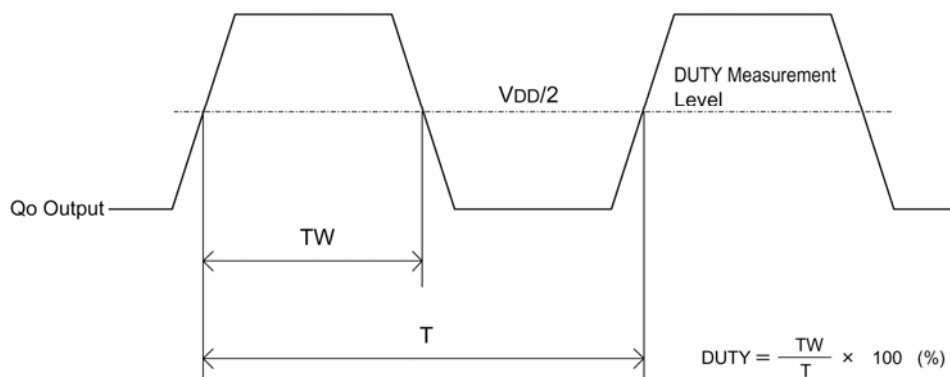

### (3) Output Disable Delay Time, Output Enable Delay Time

\*) /INH Pin Input Waveform  $t_r = t_f = \text{less than } 10\text{ns}$

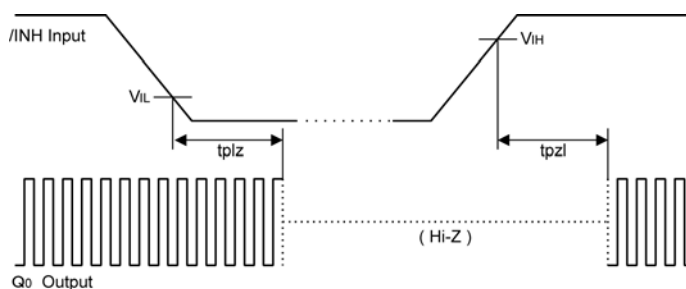



## PACKAGING INFORMATION

SOT-26

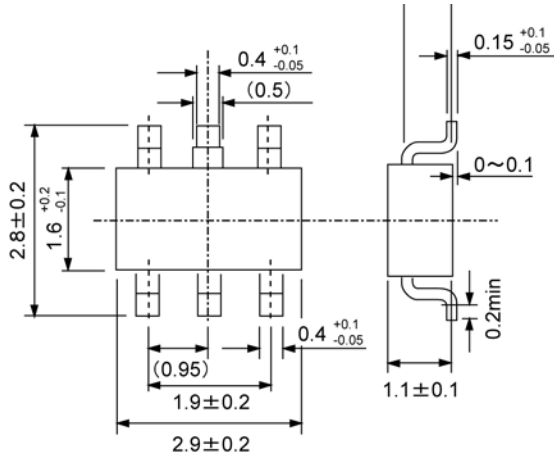

## MARKING RULE

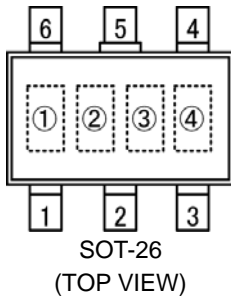

Represents product series

MARK
6

Represents divider ratio

MARK	RATIO	MARK	RATIO
C	$f_0/1$	E	$f_0/4$
D	$f_0/2$	F	$f_0/8$

Represents frequency & Rf, Cg & Cd values

MARK	Frequency (MHz)	
	5.0V	3.3V
A	-	108~125
B	-	93~110
C	108~125	80~95
D	95~110	72~83
E	80~97	65~75
F	68~83	57~67
H	55~70	-
K	45~57	-
L	40~48	-
Z	External	

Represents assembly lot number  
(Based on internal standards)

1. The products and product specifications contained herein are subject to change without notice to improve performance characteristics. Consult us, or our representatives before use, to confirm that the information in this datasheet is up to date.
2. We assume no responsibility for any infringement of patents, patent rights, or other rights arising from the use of any information and circuitry in this datasheet.
3. Please ensure suitable shipping controls (including fail-safe designs and aging protection) are in force for equipment employing products listed in this datasheet.
4. The products in this datasheet are not developed, designed, or approved for use with such equipment whose failure or malfunction can be reasonably expected to directly endanger the life of, or cause significant injury to, the user.  
(e.g. Atomic energy; aerospace; transport; combustion and associated safety equipment thereof.)
5. Please use the products listed in this datasheet within the specified ranges.  
Should you wish to use the products under conditions exceeding the specifications, please consult us or our representatives.
6. We assume no responsibility for damage or loss due to abnormal use.
7. All rights reserved. No part of this datasheet may be copied or reproduced without the prior permission of TOREX SEMICONDUCTOR LTD.

**TOREX SEMICONDUCTOR LTD.**

# Mouser Electronics

Authorized Distributor

Click to View Pricing, Inventory, Delivery & Lifecycle Information:

[Torex Semiconductor:](#)

[XC2163C51FMR-G](#) [XC2163E51EMR-G](#) [XC2163C51ZMR-G](#) [XC2163F51EMR-G](#) [XC2163C51AMR-G](#)  
[XC2163C51LMR-G](#)