

阅读申明

- 1.本站收集的数据手册和产品资料都来自互联网，版权归原作者所有。如读者和版权方有任何异议请及时告之，我们将妥善解决。
- 2.本站提供的中文数据手册是英文数据手册的中文翻译，其目的是协助用户阅读，该译文无法自动跟随原稿更新，同时也可能存在翻译上的不当。建议读者以英文原稿为参考以便获得更精准的信息。
- 3.本站提供的产品资料，来自厂商的技术支持或者使用者的心得体会等，其内容可能存在描述上的差异，建议读者做出适当判断。
- 4.如需与我们联系，请发邮件到marketing@iczoom.com，主题请标有“数据手册”字样。

Read Statement

1. The datasheets and other product information on the site are all from network reference or other public materials, and the copyright belongs to the original author and original published source. If readers and copyright owners have any objections, please contact us and we will deal with it in a timely manner.
2. The Chinese datasheets provided on the website is a Chinese translation of the English datasheets. Its purpose is for reader's learning exchange only and do not involve commercial purposes. The translation cannot be automatically updated with the original manuscript, and there may also be improper translations. Readers are advised to use the English manuscript as a reference for more accurate information.
3. All product information provided on the website refer to solutions from manufacturers' technical support or users the contents may have differences in description, and readers are advised to take the original article as the standard.
4. If you have any questions, please contact us at marketing@iczoom.com and mark the subject with "Datasheets" .



Features

- Lead free as standard (RoHS compliant*)
- Protects 1 line or 1 I/O port
- Bidirectional configuration
- ESD protection >40 kV
- Low capacitance ~3 pF typical
- Replaces 0805 MLV devices

Applications

- Cell phones
- PDAs and notebooks
- Digital cameras
- MP3 players and GPS
- USB interface

CDSOD323-TxxC – TVS Diode Array Series

General Information

The markets of portable communications, computing and video equipment are challenging the semiconductor industry to develop increasingly smaller electronic components.

Bourns offers Transient Voltage Suppressor Array diodes for surge and ESD protection applications, in SOD323 package size format. The Transient Voltage Suppressor Array series offers a choice of voltage types ranging from 3 V to 24 V in a unidirectional or bidirectional configuration. Bourns® Chip Diodes conform to JEDEC standards, are easy to handle on standard pick and place equipment and their flat configuration minimizes roll away.

The Bourns® device will meet IEC 61000-4-2 (ESD), IEC 61000-4-4 (EFT) and IEC 61000-4-5 (Surge) requirements.

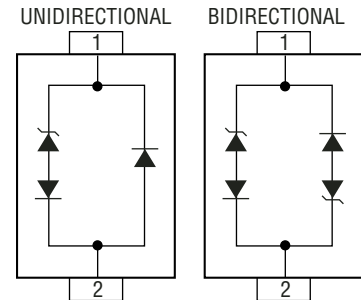

Electrical & Thermal Characteristics (@ T_A = 25 °C Unless Otherwise Noted)

Parameter	Symbol	Value	Unit
Peak Pulse Power (t _p = 8/20 μs)	P _{PP}	350	W
Operating Temperature	T _J	-55 °C to 150 °C	°C
Storage Temperature	T _{STG}	-55 °C to 150 °C	°C

Parameter	Symbol	CDSOD323-								Unit
		Uni-T03	Bi-T03C	Uni-T05	Bi-T05C	Uni-T08	Bi-T08C	Uni-T12	Bi-T12C	
Min. Breakdown Voltage @ 1 mA	V _{BR}	4.0	4.0	6.0	6.0	8.5	8.5	13.3	13.3	V
Working Peak Voltage	V _{WM}	3.3	3.3	5.0	5.0	8.0	8.0	12.0	12.0	V
Maximum Clamping Voltage @ I _p = 1 A	V _F	7.0	7.0	9.8	9.8	13.4	13.4	19.0	19.0	V
Maximum Clamping Voltage @ 8/20 μs @ I _{PP}	V _C	19.0 V @ 20 A	19.0 V @ 20 A	18.3 V @ 17 A	18.3 V @ 17 A	18.5 V @ 17 A	18.5 V @ 17 A	28.3 V @ 11 A	28.3 V @ 11 A	V
Maximum Leakage Current @ V _{WM}	I _D	5	5	5	5	2	2	1	1	μA
Typical Capacitance @ 0 V, 1 MHz	C _J	3								pF

Notes:

1. Part numbers with suffix "C" indicate bidirectional device, i.e. CDSOD323-T05C.
2. For bidirectional devices only, the electrical specifications apply in both directions.

CDSOD323-TxxC – TVS Diode Array Series

BOURNS®

Electrical & Thermal Characteristics (@ $T_A = 25^\circ\text{C}$ Unless Otherwise Noted)

Parameter	Symbol	CDSOD323-						Unit
		Uni-T15	Bi-T15C	Uni-T18	Bi-T18C	Uni-T24	Bi-T24C	
Min. Breakdown Voltage @ 1 mA	V_{BR}	16.7	16.7	20.0	20.0	26.7	26.7	V
Working Peak Voltage	V_{WM}	15.0	15.0	18.0	18.0	24.0	24.0	V
Maximum Clamping Voltage @ $I_P = 1\text{ A}$	V_F	24.0	24.0	29.0	29.0	43.0	43.0	V
Maximum Clamping Voltage @ 8/20 μs @ I_{PP}	V_C	31.8 V @ 10 A	31.8 V @ 10 A	45.0 V @ 8 A	45.0 V @ 8 A	56.0 V @ 6 A	56.0 V @ 6 A	V
Maximum Leakage Current @ V_{WM}	I_b	1						μA
Typical Capacitance @ 0 V, 1 MHz	C_J	3						pF

Notes:

1. Part numbers with suffix "C" indicate bidirectional device, i.e. CDSOD323-T05C.
2. For bidirectional devices only, the electrical specifications apply in both directions.

Performance Graphs

Peak Pulse Power vs Pulse Time

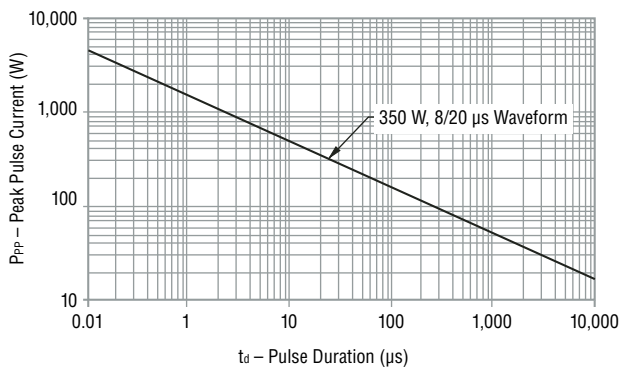

Pulse Wave Form

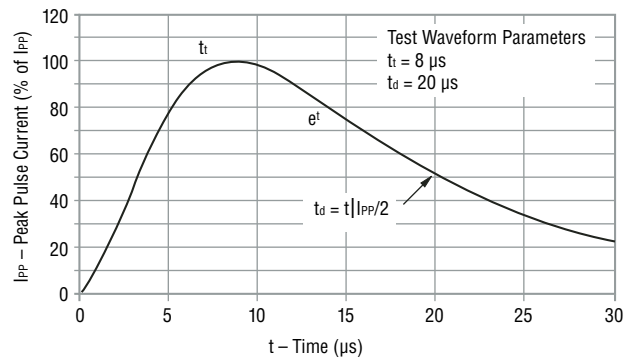

Block Diagram

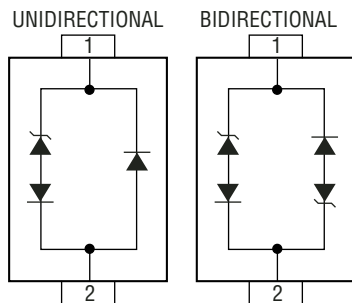

How To Order

Common Code _____ **CD SOD323 - T 05 C**
 Chip Diode _____
 Package _____
 • SOD323 = SOD-323 Package
 Model _____
 T = Transient Voltage Suppressor
 Working Peak Reverse Voltage _____
 05 = 5 V_{RWM} (Volts)
 Suffix _____
 C = Bidirectional Diode

CDSOD323-TxxC – TVS Diode Array Series



Product Dimensions

This is a molded JEDEC SOD-323 package with lead free 100 % Sn plating on the terminations. It weighs approximately 30 mg and has a flammability rating of UL 94V-0.

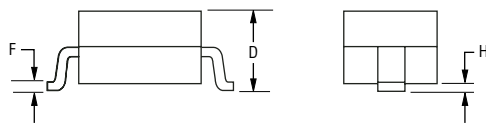
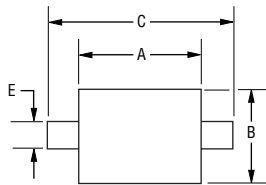

Dimensions	
A	$\frac{0.60 - 1.90}{0.063 - 0.075}$
B	$\frac{1.15 - 1.45}{0.045 - 0.057}$
C	$\frac{2.39 - 2.70}{0.094 - 0.106}$
D	$\frac{0.92 - 1.10}{0.036 - 0.043}$
E	$\frac{0.25 - 0.40}{0.010 - 0.016}$
F	$\frac{0.10 - 0.20}{0.004 - 0.008}$
H	$\frac{0.10}{0.004}$ MAX.

DIMENSIONS = $\frac{\text{MILLIMETERS}}{\text{(INCHES)}}$

Recommended Footprint

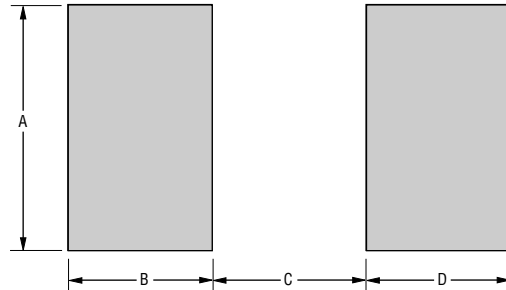

Dimensions (Nominal)	
A	$\frac{0.80}{0.031}$
B	$\frac{0.80}{0.031}$
C	$\frac{1.40}{0.055}$
D	$\frac{0.80}{0.031}$

DIMENSIONS = $\frac{\text{MILLIMETERS}}{\text{(INCHES)}}$

Typical Part Marking

Each device has device marking outlined below and the unidirectional devices have an additional Polarity Band indicating the cathode.

CDSOD323-T03	3
CDSOD323-T03C	3C
CDSOD323-T05	5
CDSOD323-T05C	5C
CDSOD323-T08	8
CDSOD323-T08C	8C
CDSOD323-T12	2
CDSOD323-T12C	2C
CDSOD323-T15	6
CDSOD323-T15C	6C
CDSOD323-T18	1
CDSOD323-T18C	1C
CDSOD323-T24	4
CDSOD323-T24C	4C

CDSOD323-TxxC – TVS Diode Array Series

BOURNS®

Packaging Information

The surface mount product is packaged in an 8 mm x 4 mm tape and reel format per EIA-481 standard.

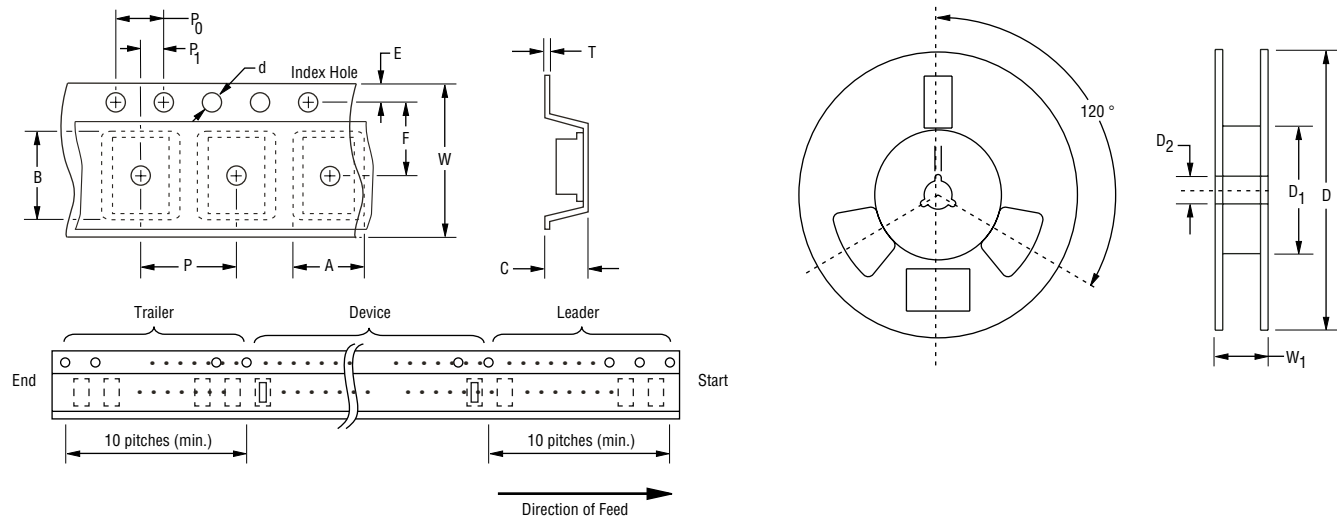

Item	Symbol	SOD-323
Carrier Width	A	$\frac{1.55 \pm 0.10}{(0.061 - 0.004)}$
Carrier Length	B	$\frac{2.90 \pm 0.10}{(0.114 - 0.004)}$
Carrier Depth	C	$\frac{1.35 \pm 0.10}{(0.053 - 0.004)}$
Sprocket Hole	d	$\frac{1.55 \pm 0.05}{(0.061 - 0.002)}$
Reel Outside Diameter	D	$\frac{178}{(7.008)}$
Reel Inner Diameter	D ₁	$\frac{80.0}{(3.150)}$ Min.
Feed Hole Diameter	D ₂	$\frac{13.0 \pm 0.20}{(0.512 - 0.008)}$
Sprocket Hole Position	E	$\frac{1.75 \pm 0.10}{(0.069 - 0.004)}$
Punch Hole Position	F	$\frac{3.50 \pm 0.05}{(0.138 - 0.002)}$
Punch Hole Pitch	P	$\frac{4.00 \pm 0.10}{(0.157 - 0.004)}$
Sprocket Hole Pitch	P ₀	$\frac{4.00 \pm 0.10}{(0.157 - 0.004)}$
Embossment Center	P ₁	$\frac{2.00 \pm 0.05}{(0.079 - 0.002)}$
Overall Tape Thickness	T	$\frac{0.20 \pm 0.10}{(0.008 - 0.004)}$
Tape Width	W	$\frac{8.00 \pm 0.20}{(0.315 - 0.008)}$
Reel Width	W ₁	$\frac{13.5}{(0.531)}$ Max.
Quantity per Reel	—	3,000



Reliable Electronic Solutions

Asia-Pacific:

Tel: +886-2 2562-4117 • Fax: +886-2 2562-4116

Europe:

Tel: +41-41 768 5555 • Fax: +41-41 768 5510

The Americas:

Tel: +1-951 781-5500 • Fax: +1-951 781-5700

www.bourns.com