

阅读申明

- 1.本站收集的数据手册和产品资料都来自互联网，版权归原作者所有。如读者和版权方有任何异议请及时告之，我们将妥善解决。
- 2.本站提供的中文数据手册是英文数据手册的中文翻译，其目的是协助用户阅读，该译文无法自动跟随原稿更新，同时也可能存在翻译上的不当。建议读者以英文原稿为参考以便获得更精准的信息。
- 3.本站提供的产品资料，来自厂商的技术支持或者使用者的心得体会等，其内容可能存在描述上的差异，建议读者做出适当判断。
- 4.如需与我们联系，请发邮件到marketing@iczoom.com，主题请标有“数据手册”字样。

Read Statement

1. The datasheets and other product information on the site are all from network reference or other public materials, and the copyright belongs to the original author and original published source. If readers and copyright owners have any objections, please contact us and we will deal with it in a timely manner.
2. The Chinese datasheets provided on the website is a Chinese translation of the English datasheets. Its purpose is for reader's learning exchange only and do not involve commercial purposes. The translation cannot be automatically updated with the original manuscript, and there may also be improper translations. Readers are advised to use the English manuscript as a reference for more accurate information.
3. All product information provided on the website refer to solutions from manufacturers' technical support or users the contents may have differences in description, and readers are advised to take the original article as the standard.
4. If you have any questions, please contact us at marketing@iczoom.com and mark the subject with "Datasheets" .

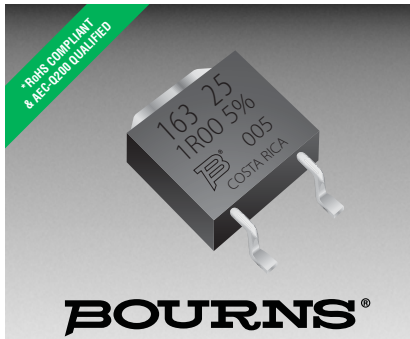

Features

- Smaller than a D²PAK package
- Low inductance
- Resistor electrically isolated from the backplate
- High power rating
- Compatible with lead free solder reflow temperatures
- RoHS compliant*

- AEC-Q200 qualified

Applications

- Power supplies
- Motor drives
- Test and measurement
- Rectifiers

PWR163 Series Power Resistor

General Information

The PWR163 Series is a DPAK style surface mount power resistor. It has a very low inductance making it ideal for high frequency applications such as amplifiers for audio or wireless base stations. It has excellent pulse characteristics as well, allowing it to be used in current limiting or capacitor discharge circuits.

Electrical & Thermal Characteristics

Parameter	Value(s)
Resistance (See Popular Resistance Values table)	0.02 Ω to 130 K Ω
Power Rating @ 25 °C Case Temperature	25 W
Tolerance	$\pm 1\%$ **, $\pm 5\%$
TCR	± 100 PPM/°C
Thermal Resistance - R _{thj}	5.2 °C/W
Inductance	0.1 μ H maximum
Operating Voltage	$\sqrt{P \cdot R}$ with a maximum of 250 V
Dielectric Strength	2 KV AC
Insulation Resistance	10 G Ω
Operating Temperature	-55 °C to 155 °C

** Available for most values. Check Popular Resistance Values table.

Reliability Characteristics

Parameter	Specification
Short Term Overload (2x Pr for R < 2 Ω , 1.6 x Pr for R \geq 2 Ω , V < 1.5 x Operating Voltage)	$\Delta R \pm 0.25\%$
Load Life (1000 hours at rated power)	$\Delta R \pm 1.0\%$
Thermal Shock (-55 °C to 155 °C, 5 cycles)	$\Delta R \pm 0.5\%$
Resistance to Soldering Heat (10 seconds at 270 °C)	$\Delta R \pm 0.5\%$
Vibration (20 G 10-2000 Hz .06" D.A.)	$\Delta R \pm 0.25\%$
Moisture Sensitivity Level	1

Derating Curve

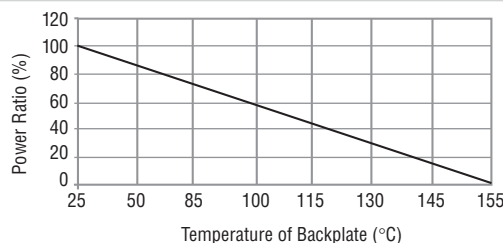

Material Characteristics

Resistor Thick film
Substrate Alumina (AL2O3)
Housing Epoxy
Pins Tinned Copper (Sn/Cu)
Flammability Conforms to UL-94V0

Popular Resistance Values

Code	Resistance Value	Code	Resistance Value
R020	0.02 Ω ***	1000	100 Ω
R025	0.025 Ω ***	1200	120 Ω
R030	0.03 Ω ***	1500	150 Ω
R033	0.033 Ω ***	2000	200 Ω
R040	0.04 Ω ***	2500	250 Ω
R050	0.05 Ω ***	3000	300 Ω
R075	0.075 Ω ***	3300	330 Ω
R100	0.1 Ω	4000	400 Ω
R150	0.15 Ω	4700	470 Ω
R200	0.2 Ω	5000	500 Ω
R250	0.25 Ω	5600	560 Ω
R300	0.3 Ω	7500	750 Ω
R330	0.33 Ω	1001	1.0 K Ω
R400	0.4 Ω	1501	1.5 K Ω
R500	0.5 Ω	2001	2.0 K Ω
R750	0.75 Ω	2501	2.5 K Ω
1R00	1 Ω	3001	3.0 K Ω
1R50	1.5 Ω	3301	3.3 K Ω
2R00	2 Ω	4001	4.0 K Ω
2R50	2.5 Ω	5001	5.0 K Ω
3R00	3 Ω	7501	7.5 K Ω
3R30	3.3 Ω	1002	10 K Ω
4R00	4 Ω	1502	15 K Ω
5R00	5 Ω	2002	20 K Ω
7R50	7.5 Ω	2502	25 K Ω
8R00	8 Ω	3002	30 K Ω
10R0	10 Ω	3302	33 K Ω
12R0	12 Ω	4002	40 K Ω
15R0	15 Ω	4702	47 K Ω
20R0	20 Ω	5002	50 K Ω
25R0	25 Ω	5602	56 K Ω
27R0	27 Ω	6802	68 K Ω
30R0	30 Ω	7502	75 K Ω
33R0	33 Ω	8202	82 K Ω
40R0	40 Ω	1003	100 K Ω
47R0	47 Ω	1153	115 K Ω
50R0	50 Ω	1203	120 K Ω
56R0	56 Ω	1253	125 K Ω
75R0	75 Ω	1303	130 K Ω

*** 5 % Tolerance

*RoHS Directive 2002/95/EC Jan. 27, 2003 including annex and RoHS Recast 2011/65/EU June 8, 2011. Specifications are subject to change without notice.

The device characteristics and parameters in this data sheet can and do vary in different applications and actual device performance may vary over time.

Users should verify actual device performance in their specific applications.

PWR163 Series Power Resistor

BOURNS®

Soldering Profile

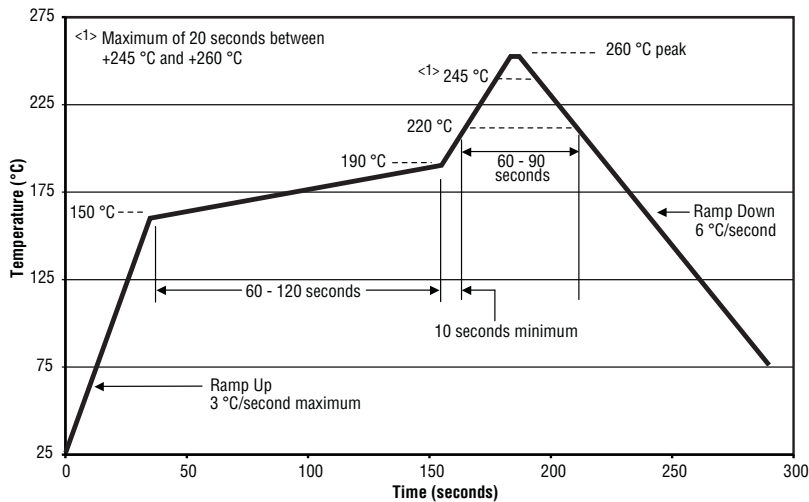

Power dissipation is 2.8 W at an ambient temperature of 25 °C when mounted on a double-sided copper board using FR4 standard, 70 μm of copper, 39 x 30 x 1.6 mm.

Pulse Power Rating

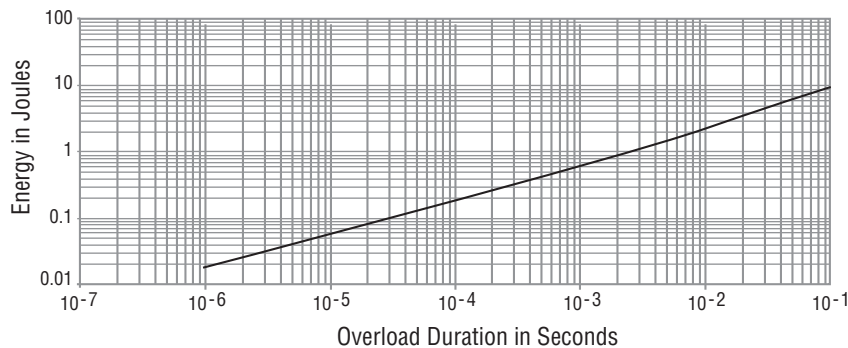

The energy absorbed by the resistor expressed in Joules can be calculated by multiplying the peak power of the pulse in watts times the length of the pulse in seconds.

The energy should not exceed the limits shown in the graph. The overload voltage should not exceed 1.5 times the maximum operating voltage.

How to Order

PWR 163 S - 25 - 10R0 J E

Model _____
 PWR = Power Resistor

Package _____
 163 = DPAK Style

Pin Style _____
 S = Surface Mount

Power _____
 25 = 25 W

Resistance Value _____
 <100 ohms ... "R" represents decimal point (examples: 7R50 = 7.5 Ω; R500 = 0.5 Ω)
 ≥100 ohms... First three digits are significant, fourth digit represents number of zeros to follow (examples: 2000 = 200 ohms; 3002 = 30K ohms)

Absolute Tolerance _____
 J = 5 %
 F = 1 %

Packaging _____
 E = Tape & Reel
 Blank = Tubes

Typical Part Marking

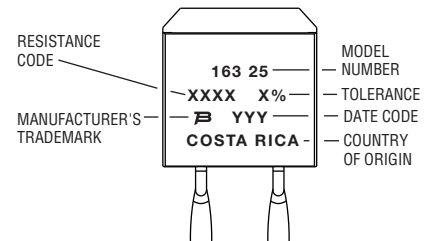

PWR163 Series Power Resistor

BOURNS®

Product Dimensions

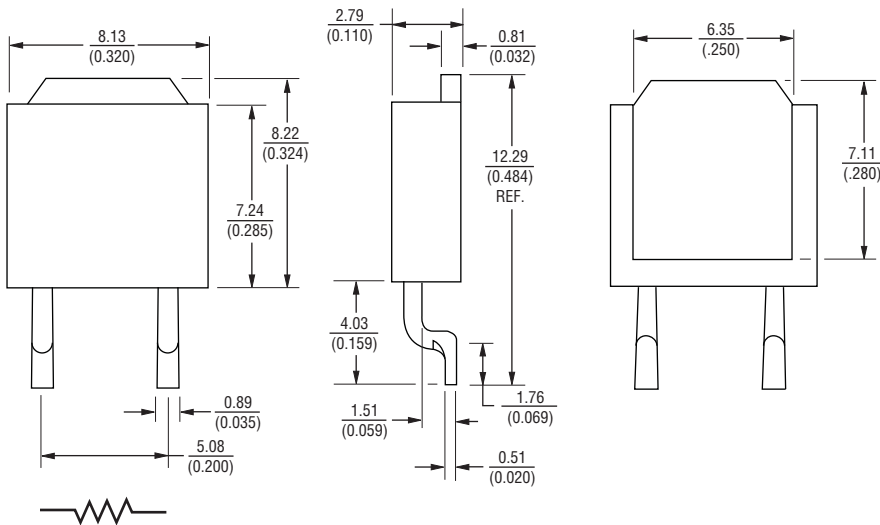

Recommended Pad Layout

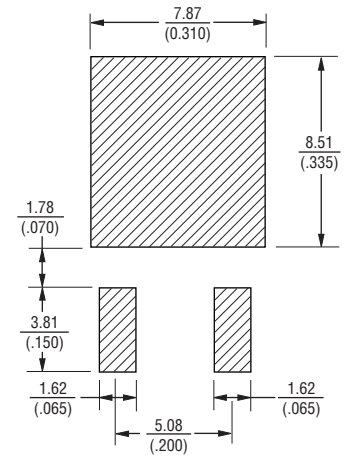

Packaging Specifications

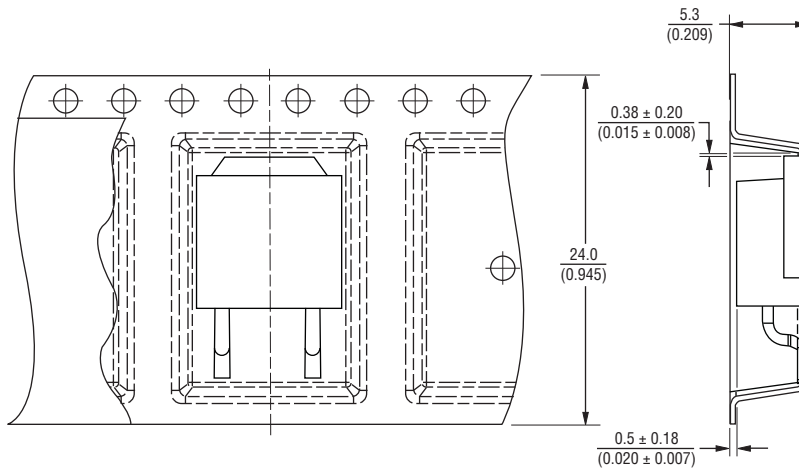

DIMENSIONS: $\frac{\text{MM}}{\text{(INCHES)}}$
 TOLERANCE: ± 0.38 (±0.015) UNLESS OTHERWISE NOTED

BOURNS®

Asia-Pacific: Tel: +886-2 2562-4117 • Fax: +886-2 2562-4116

Europe: Tel: +36 88 520 390 • Fax: +36 88 520 211

The Americas: Tel: +1-951 781-5500 • Fax: +1-951 781-5700

www.bourns.com

REV. 10/13

Specifications are subject to change without notice.

The device characteristics and parameters in this data sheet can and do vary in different applications and actual device performance may vary over time. Users should verify actual device performance in their specific applications.