

## 阅读申明

- 1.本站收集的数据手册和产品资料都来自互联网，版权归原作者所有。如读者和版权方有任何异议请及时告之，我们将妥善解决。
- 2.本站提供的中文数据手册是英文数据手册的中文翻译，其目的是协助用户阅读，该译文无法自动跟随原稿更新，同时也可能存在翻译上的不当。建议读者以英文原稿为参考以便获得更精准的信息。
- 3.本站提供的产品资料，来自厂商的技术支持或者使用者的心得体会等，其内容可能存在描述上的差异，建议读者做出适当判断。
- 4.如需与我们联系，请发邮件到marketing@iczoom.com，主题请标有“数据手册”字样。

## Read Statement

1. The datasheets and other product information on the site are all from network reference or other public materials, and the copyright belongs to the original author and original published source. If readers and copyright owners have any objections, please contact us and we will deal with it in a timely manner.
2. The Chinese datasheets provided on the website is a Chinese translation of the English datasheets. Its purpose is for reader's learning exchange only and do not involve commercial purposes. The translation cannot be automatically updated with the original manuscript, and there may also be improper translations. Readers are advised to use the English manuscript as a reference for more accurate information.
3. All product information provided on the website refer to solutions from manufacturers' technical support or users the contents may have differences in description, and readers are advised to take the original article as the standard.
4. If you have any questions, please contact us at marketing@iczoom.com and mark the subject with "Datasheets" .



The Future of Analog IC Technology®

# MP1488

## 800mA Fixed Frequency White LED Driver

### DESCRIPTION

The MP1488 is a step-up converter designed for driving up to 27 WLEDs (9 strings of 3 WLEDs each) from a 5V system rail. The MP1488 uses a current mode, fixed frequency architecture to regulate the LED current, which is measured through an external current sense resistor. Its low 104mV feedback voltage reduces power loss and improves efficiency. The OV pin monitors the output voltage and turns off the converter if an over-voltage condition is present due to an open circuit condition.

The MP1488 includes under-voltage lockout, current limiting and thermal overload protection preventing damage in the event of an output overload.

The MP1488 is available in a small 6-pin TSOT23 package.

### FEATURES

- 2.5V to 6V Input Voltage Range
- On Board Power MOSFET
- Drives up to 27 White LEDs at 5V Input
- Up to 92% Efficiency
- Over 1MHz Fixed Switching Frequency
- Open Load Shutdown
- Low 104mV Feedback Voltage
- Soft-Start/PWM Dimming
- UVLO, Thermal Shutdown
- Internal 800mA Current Limit
- Available in a TSOT23-6 Package

### APPLICATIONS

- Cell Phones
- Handheld Computers and PDAs
- Digital Still Cameras
- Small LCD Displays

"MPS" and "The Future of Analog IC Technology" are Registered Trademarks of Monolithic Power Systems, Inc.

### TYPICAL APPLICATION

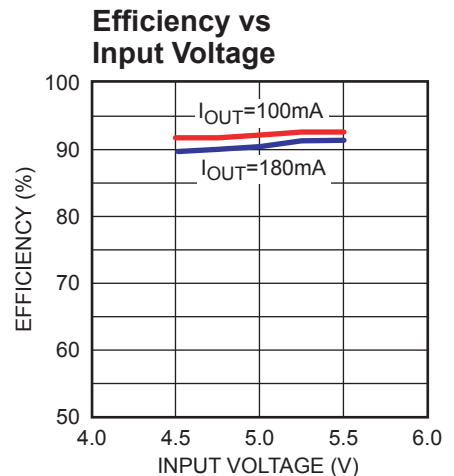
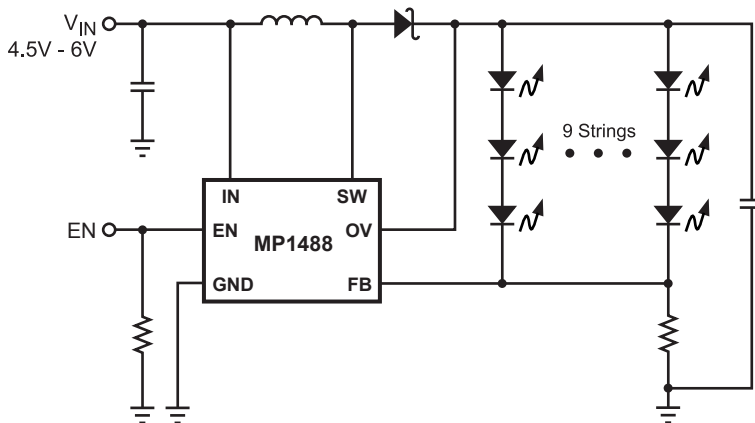

## PACKAGE REFERENCE

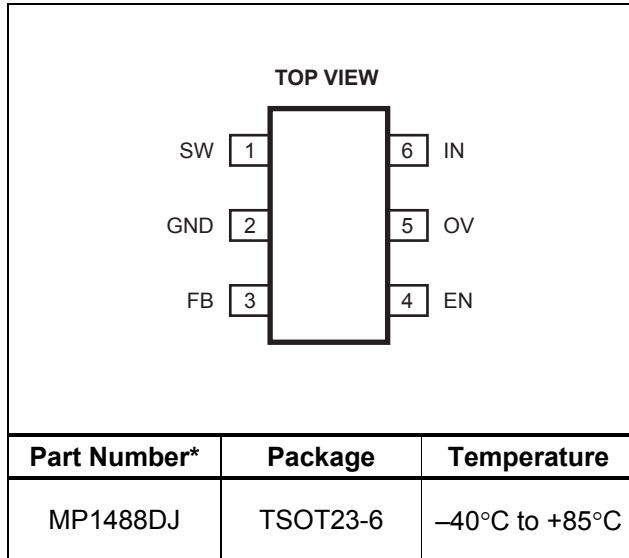

\* For Tape & Reel, add suffix -Z (eg. MP1488DJ-Z)  
 For RoHS compliant packaging, add suffix -LF  
 (eg. MP1488DJ-LF-Z)

## ABSOLUTE MAXIMUM RATINGS <sup>(1)</sup>

SW Pin.....-0.5V to +28.5V  
 All Other Pins.....-0.3V to +6.5V  
 Storage Temperature .....-55°C to +150°C

## Recommended Operating Conditions <sup>(2)</sup>

IN Supply Voltage..... 2.5V to 6V  
 Output Voltage.....  $V_{IN}$  to 25V  
 Operating Temperature .....-40°C to +85°C

## Thermal Resistance <sup>(3)</sup>

$\theta_{JA}$   $\theta_{JC}$   
 TSOT23-6..... 220 .... 110.. °C/W

### Notes:

- 1) Exceeding these ratings may damage the device.
- 2) The device is not guaranteed to function outside of its operating conditions.
- 3) Measured on approximately 1" square of 1 oz copper.

## ELECTRICAL CHARACTERISTICS

$V_{IN} = V_{EN} = 5V$ ,  $T_A = +25^\circ C$ , unless otherwise noted.

Parameters	Symbol	Condition	Min	Typ	Max	Units
Operating Input Voltage	$V_{IN}$		2.5		6	V
Supply Current (Shutdown)		$V_{EN} = 0V$		0.1	1	$\mu A$
Supply Current (Quiescent)		$V_{FB} = 0.15V$		690	750	$\mu A$
Switching Frequency	$f_{SW}$		1.0	1.3	1.5	MHz
Maximum Duty Cycle		$V_{FB} = 0V$	85	92		%
<b>Under Voltage Lockout</b>						
IN Under Voltage Lockout	UVLO	$V_{IN}$ Rising		2.25	2.45	V
Under Voltage Lockout Hysteresis				92		mV
Open Lamp Shutdown Threshold	$V_{OV}$	$V_{OV}$ Rising		28		V
<b>Enable</b>						
EN Threshold		$V_{EN}$ Rising, $V_{IN} = 5V$	1.0	1.35	1.6	V
EN Threshold		$V_{EN}$ Rising, $V_{IN} = 2.5V$	0.8			V
EN Hysteresis				90		mV
EN Input Bias Current		$V_{EN} = 0V, 5V$			1	$\mu A$

**ELECTRICAL CHARACTERISTICS** *(continued)*
 $V_{IN} = V_{EN} = 5V$ ,  $T_A = +25^{\circ}C$ , unless otherwise noted.

Parameters	Symbol	Condition	Min	Typ	Max	Units
<b>Feedback</b>						
FB Voltage			94	104	114	mV
FB Input Bias Current		$V_{FB} = 0.1V$	-600	-300		nA
<b>Output Switch</b>						
SW On-Resistance <sup>(4)</sup>	$R_{ON}$			0.5		$\Omega$
SW Current Limit <sup>(4)</sup>		Duty Cycle = 60%		800		mA
Thermal Shutdown <sup>(4)</sup>				160		$^{\circ}C$

**Notes:**

4) Guaranteed by design.

**PIN FUNCTIONS**

TSOT23-6 Pin #	Name	Description
1	SW	Power Switch Output. SW is the drain of the internal MOSFET switch. Connect the power inductor and output rectifier to SW. SW can swing between GND and 25V.
2	GND	Ground.
3	FB	Feedback Input. The MP1488 regulates the voltage across the current sense resistor between FB and GND. Connect a current sense resistor from the bottom of the LED string to GND. Connect the bottom of the LED string to FB. The regulation voltage is 104mV.
4	EN	Regulator On/Off Control Input. A high input at EN turns on the converter, and a low input turns it off. When not used, connect EN to the input source for automatic startup. <b>The EN pin cannot be left floating.</b>
5	OV	Over Voltage Input. OV measures the output voltage for open circuit protection. Connect OV to the output at the top of the LED string.
6	IN	Input Supply Pin. Must be locally bypassed.

## OPERATION

The MP1488 uses a constant frequency, peak current mode boost regulator architecture to regulate the strings of white LEDs. Refer to the block diagram in Figure 1 for details.

At the start of each oscillator cycle the FET is turned on through the control circuitry. To prevent sub-harmonic oscillations at duty cycles greater than 50%, a stabilizing ramp is added to the output of the current sense amplifier and the result is fed into the positive input of the PWM comparator. When this voltage equals the output voltage of the error amplifier the power FET is turned off.

The voltage at the output of the error amplifier is an amplified version of the difference between the 104mV reference voltage and the feedback voltage. In this way the peak current level keeps the output in regulation.

If the feedback voltage starts to drop, the output of the error amplifier increases. This results in more current flowing through the power FET, thus increasing the power delivered to the output.

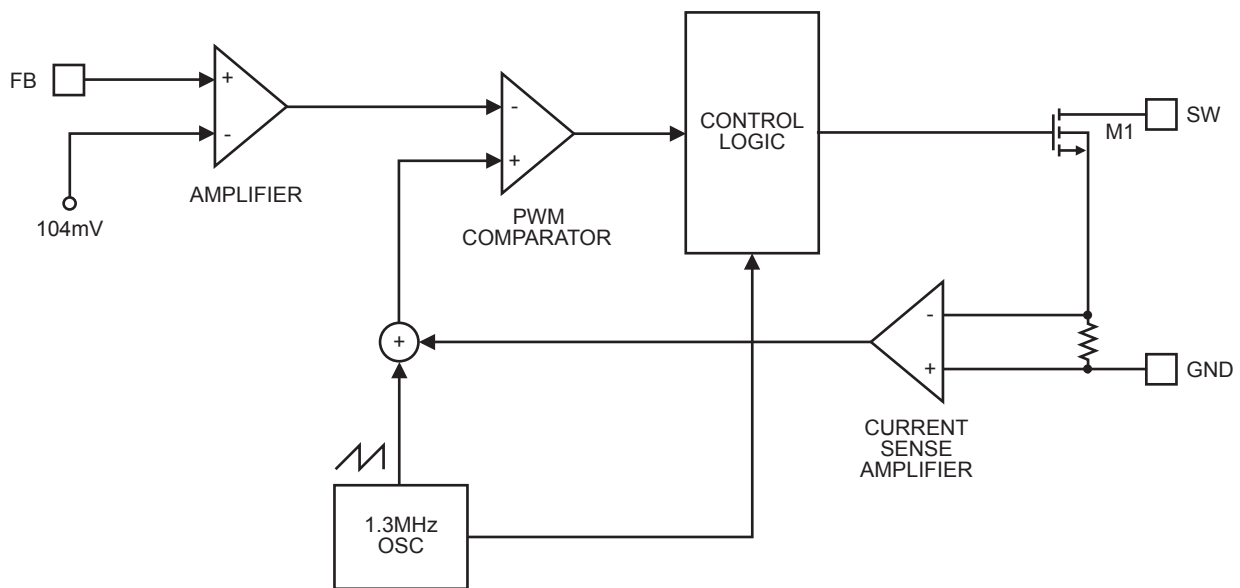

**Figure 1—Functional Block Diagram**

APPLICATION INFORMATION

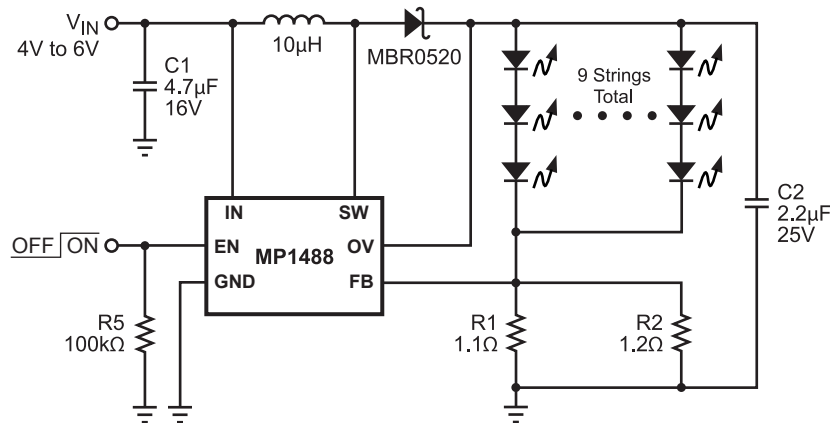

Figure 2—Circuit for Driving 27 WLEDs

A typical application circuit is provided in Figure 2. The 27 white LEDs can be driven from a voltage supply range of 4V to 6V at a total output current of 180mA. A 2.2µF output capacitor is sufficient for most applications but up to 1µF may be used. A 10µH inductor with low DCR (inductor resistance) is recommended to improve efficiency. A 4.7µF ceramic capacitor is recommended for the input capacitance in the real system. Schottky diodes with fast recovery and a low forward voltage are recommended. Schottky diodes with a 500mA rating are sufficient for the MP1488. The switching characteristics during normal operation can be seen in Figure 3. The MP1488 has internal soft-start to limit the amount of current through the IN pin at startup and to also limit the amount of overshoot on the output. The current limit is increased by a fourth every 40µs giving a total soft-start time of 120µs.

Steady State Operation

V<sub>IN</sub> = 5V, 27 LEDs, 180mA

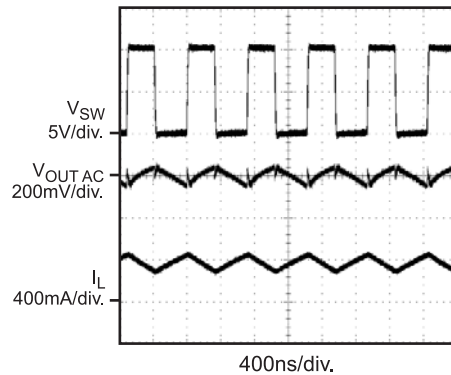
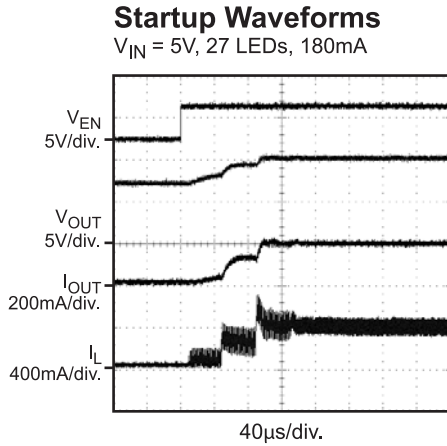

Figure 3—Steady State Operation

Figure 4 shows the startup behavior of the MP1488. The ramped voltage added to the current sense amplifier reduces the current output as the duty cycle increases. As more LEDs are added, the output voltage rises but the current that can be delivered to the load is reduced as well.



**Figure 4—Startup Waveforms**

**Setting the LED Current**

The LED current is controlled by the feedback resistors R1 and R2, as shown in Figure 2. The current through the LEDs is given by the equation:

$$I_{LED} = 104\text{mV} \times \frac{R1 + R2}{R1 \times R2}$$

Table 1 shows the selection of resistors for a given LED current.

**Table 1— $I_{LED}$  vs. R1**

$I_{LED}$ (mA)	R1 ( $\Omega$ )	R2 ( $\Omega$ )
10	10.4	N/A
50	2.08	N/A
100	1.04	N/A
150	1.5	1.3
180	1.2	1.1

**Analog and Digital Dimming**

There are three methods to control dimming for the MP1488 during normal operation. The first method uses DC voltage to control the feedback voltage. This is shown in Figure 6. As the DC voltage increases, current starts flowing down R1, R2 and R3. The loop will continue to regulate the feedback voltage to 104mV. Thus the current has to decrease through the LEDs by the same amount of current as is being injected from the DC voltage source. With a  $V_{DC}$  from 0V to 2V, the resistor values shown for R2 and R3 can control the LED current from 0mA to 20mA.

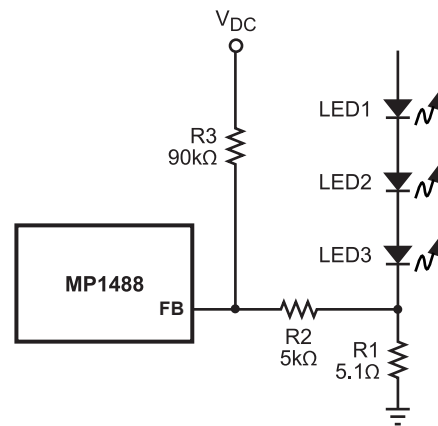

**Figure 6—Dimming Control Using a DC Voltage**

Other applications require a logic signal to control dimming. This is shown in Figure 7. The PWM signal is applied to the EN pin of the MP1488. The LEDs will switch between full load to completely shut off. The average current through the LEDs will increase proportionally to the duty cycle of the PWM signal. The PWM signal used in Figure 7 should be 1KHz or below due to the soft-start function.

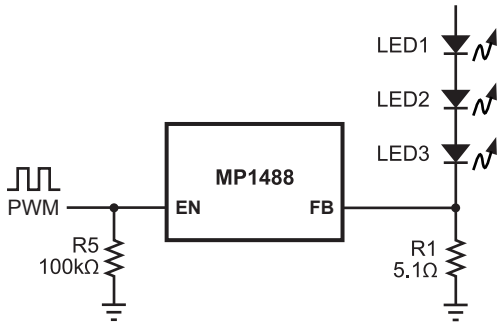

**Figure 7—PWM Dimming Control Using a Logic Signal**

If the PWM signal is above 1KHz, dimming can be achieved using the circuit shown in Figure 8.

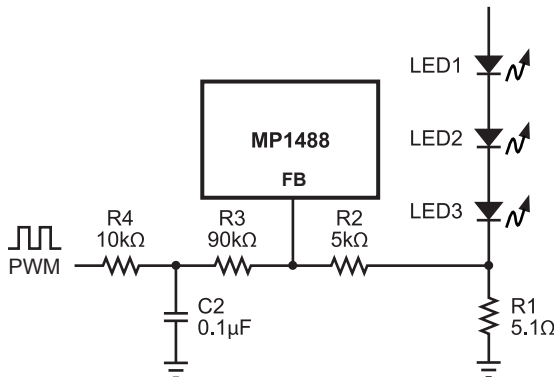
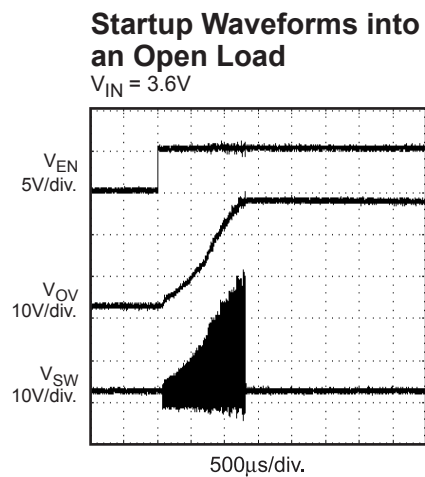

**Figure 8— Dimming Control Using a Filtered PWM Signal**

**Open Load Protection**

Open Load protection will shut off the MP1488 if the output voltage rises too high when the OV pin is tied to the output. In some cases an LED may fail. This will result in the feedback voltage always remaining at zero.

The part will run at maximum duty cycle boosting the output voltage higher and higher. By tying the OV pin to the top of the LED string the MP1488 can check for this condition. If the output exceeds 28V, the MP1488 will shut down. The part will not switch again until the power is recycled. Figure 9 shows the behavior of the MP1488 into an open load.



**Figure 9—Startup Waveforms into an Open Load**

**Layout Considerations**

Careful attention must be paid to the PCB board layout and component placement. Proper layout of the high frequency switching path is critical to prevent noise and electromagnetic interference problems. Due to high frequency switching, the length and area of all the traces connected to the switch node should be minimized.



## PACKAGE INFORMATION

### TSOT23-6

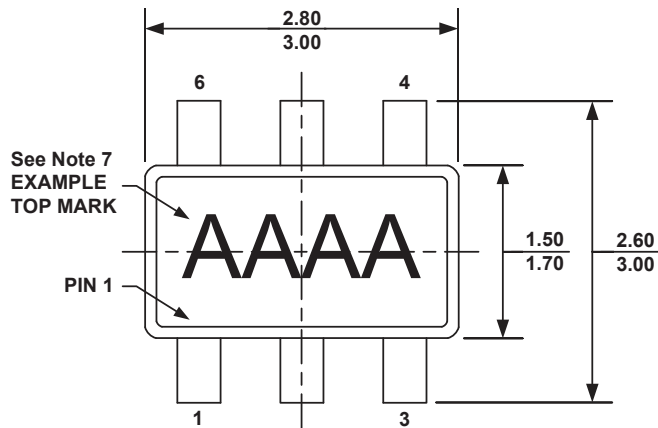

**TOP VIEW**

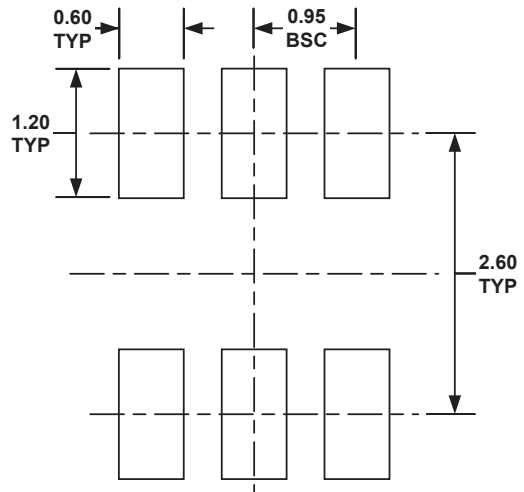

**RECOMMENDED LAND PATTERN**

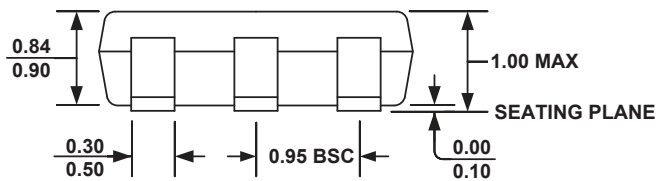

**FRONT VIEW**

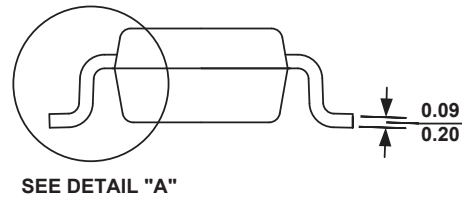

**SIDE VIEW**

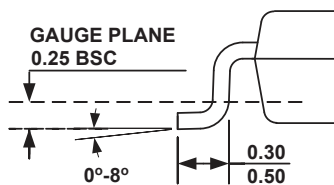

**DETAIL A**

#### NOTE:

- 1) ALL DIMENSIONS ARE IN MILLIMETERS.
- 2) PACKAGE LENGTH DOES NOT INCLUDE MOLD FLASH, PROTRUSION OR GATE BURR.
- 3) PACKAGE WIDTH DOES NOT INCLUDE INTERLEAD FLASH OR PROTRUSION.
- 4) LEAD COPLANARITY (BOTTOM OF LEADS AFTER FORMING) SHALL BE 0.10 MILLIMETERS MAX.
- 5) DRAWING CONFORMS TO JEDEC MO-193, VARIATION AB.
- 6) DRAWING IS NOT TO SCALE.
- 7) PIN 1 IS LOWER LEFT PIN WHEN READING TOP MARK FROM LEFT TO RIGHT, (SEE EXAMPLE TOP MARK)

**NOTICE:** The information in this document is subject to change without notice. Users should warrant and guarantee that third party Intellectual Property rights are not infringed upon when integrating MPS products into any application. MPS will not assume any legal responsibility for any said applications.