

阅读申明

- 1.本站收集的数据手册和产品资料都来自互联网，版权归原作者所有。如读者和版权方有任何异议请及时告之，我们将妥善解决。
- 2.本站提供的中文数据手册是英文数据手册的中文翻译，其目的是协助用户阅读，该译文无法自动跟随原稿更新，同时也可能存在翻译上的不当。建议读者以英文原稿为参考以便获得更精准的信息。
- 3.本站提供的产品资料，来自厂商的技术支持或者使用者的心得体会等，其内容可能存在描述上的差异，建议读者做出适当判断。
- 4.如需与我们联系，请发邮件到marketing@iczoom.com，主题请标有“数据手册”字样。

Read Statement

1. The datasheets and other product information on the site are all from network reference or other public materials, and the copyright belongs to the original author and original published source. If readers and copyright owners have any objections, please contact us and we will deal with it in a timely manner.
2. The Chinese datasheets provided on the website is a Chinese translation of the English datasheets. Its purpose is for reader's learning exchange only and do not involve commercial purposes. The translation cannot be automatically updated with the original manuscript, and there may also be improper translations. Readers are advised to use the English manuscript as a reference for more accurate information.
3. All product information provided on the website refer to solutions from manufacturers' technical support or users the contents may have differences in description, and readers are advised to take the original article as the standard.
4. If you have any questions, please contact us at marketing@iczoom.com and mark the subject with "Datasheets" .

8-A, 12-V INPUT NONISOLATED WIDE-OUTPUT ADJUST SIP MODULE

FEATURES

- 8 A Output Current
- 12-V Input Voltage
- Wide-Output Voltage Adjust (1.2 V to 5.5 V)/(0.8 V to 1.8 V)
- Efficiencies up to 93%
- On/Off Inhibit
- Prebias Start Up
- Undervoltage Lockout
- Auto-Track™ Sequencing
- Output Overcurrent Protection (Nonlatching, Auto-Reset)
- Operating Temperature: –40°C to 85°C
- Safety Agency Approvals: UL/IEC/CSA-22.2 60950-1
- POLA™ Alliance Compatible

APPLICATIONS

- Multivoltage Digital Systems
- High-End Computing
- Networking
- 12-V Intermediate Bus Architectures



DESCRIPTION

The PTV12010 series of non-isolated power modules are part of a new class of complete dc/dc switching regulator modules from Texas Instruments. These modules combine high performance with double-sided, surface mount construction to give designers the flexibility to power the most complex multiprocessor digital systems using off-the-shelf catalog parts.

The PTV12010 series is produced in an 8-pin, single in-line pin (SIP) package. The SIP footprint minimizes board space, and offers an alternate package option for space conscious applications. Operating from a 12-V input bus, the series provides step-down conversion to a wide range of output voltages, at up to 8 A of output current. The output voltage of the W-suffix parts can be set to any value over the range of 1.2 V to 5.5 V. The L-suffix parts have an adjustment range of 0.8 V to 1.8 V. The output voltage is set using a single external resistor.

This series includes Auto-Track™. Auto-Track™ simplifies the task of supply-voltage sequencing in a power system by enabling the output voltage of multiple modules to accurately track each other, or any external voltage, during power up and power down.

Other operating features include an on/off inhibit, and the ability to start up into an existing output voltage or prebias. A nonlatching overcurrent trip and overtemperature shutdown provide protection against load faults.

Target applications include complex multivoltage, multiprocessor systems that incorporate the industry's high-speed DSPs, microprocessors, and bus drivers.

For start-up into a non-prebiased output, review page 13 in the *Application Information* section.

For start-up into a prebiased output, review page 17 in the *Application Information* section.



Please be aware that an important notice concerning availability, standard warranty, and use in critical applications of Texas Instruments semiconductor products and disclaimers thereto appears at the end of this data sheet.

POLA, Auto-Track, TMS320 are trademarks of Texas Instruments.



These devices have limited built-in ESD protection. The leads should be shorted together or the device placed in conductive foam during storage or handling to prevent electrostatic damage to the MOS gates.

STANDARD APPLICATION

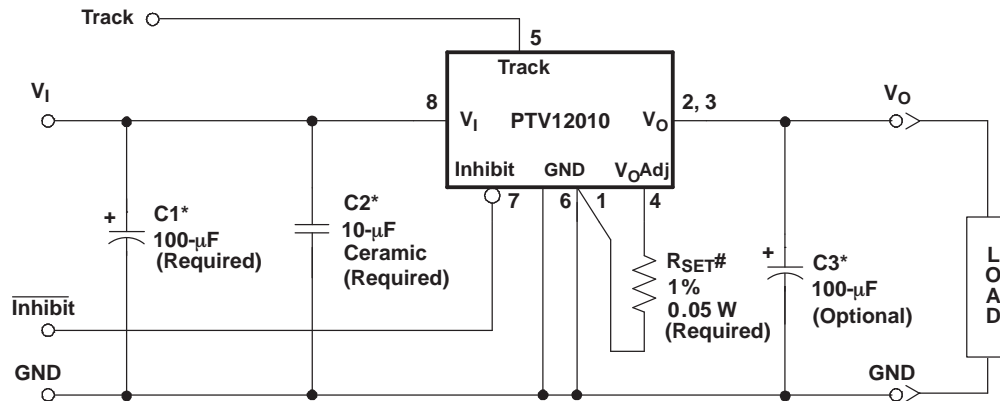

*See the application information for capacitor recommendation.
#R_{SET} is Required to adjust the output voltage higher than its lowest value. See the application information for values.

ORDERING INFORMATION

PTV12010 (Basic Model)			
Output Voltage	Part Number	DESCRIPTION	Package ⁽¹⁾
1.2 V – 5.5 V (Adjustable)	PTV12010WAH	Horizontal T/H	EVA
0.8 V – 1.8 V (Adjustable)	PTV12010LAH	Horizontal T/H	EVA

(1) See the applicable package drawing for dimensions and PC board layout.

ABSOLUTE MAXIMUM RATINGS

over operating free-air temperature range unless otherwise noted⁽¹⁾

			UNIT
V _(Track)	Track input		–0.3 V to V _I +0.3 V
T _A	Operating temperature range	Over V _I range	–40°C to 85°C
	Lead temperature	5 seconds	260°C ⁽²⁾
T _{stg}	Storage temperature		–55°C to 125°C
V _(Inhibit)	Inhibit (pin 12) input voltage		–0.3 V to 7 V

- Stresses beyond those listed under absolute maximum ratings may cause permanent damage to the device. These are stress ratings only, and functional operation of the device at these or any other conditions beyond those indicated under recommended operating conditions is not implied. Exposure to absolute-maximum-rated conditions for extended periods may affect device reliability.
- This product is not compatible with surface-mount reflow solder processes.

PACKAGE SPECIFICATIONS

PTV12010x (Suffix AH)		
Weight		2.6 grams
Flammability	Meets UL 94 V-O	
Mechanical shock	Per Mil-STD-883D, Method 2002.3, 1 ms, 1/2 sine, mounted	
Mechanical vibration	Mil-STD-883D, Method 2007.2, 20 Hz - 2000 Hz	

(1) Qualification limit.

ELECTRICAL CHARACTERISTICS

operating at 25°C free-air temperature, $V_I = 12\text{ V}$, $V_O = 3.3\text{ V}$, $C_1 = 100\text{ }\mu\text{F}$, $C_2 = 10\text{ }\mu\text{F}$, $C_3 = 0\text{ }\mu\text{F}$, and $I_O = I_O\text{ max}$ (unless otherwise noted)

PARAMETER	TEST CONDITIONS	PTV12010W			UNIT	
		MIN	TYP	MAX		
I_O Output current	Natural convection airflow	0		8 ⁽¹⁾	A	
V_I Input voltage range	Over I_O load range	10.8		13.2	V	
V_O	Set-point voltage tolerance			$\pm 2\%$ ⁽²⁾		
	Temperature variation	$-40^\circ\text{C} < T_A < 85^\circ\text{C}$		$\pm 0.5\%$		
	Line regulation	Over V_I range		± 10	mV	
	Load regulation	Over I_O range		± 12	mV	
	Total output variation	Includes set-point, line, load, $-40^\circ\text{C} \leq T_A \leq 85^\circ\text{C}$			± 3 ⁽²⁾	$\%V_O$
	Adjust range	Over V_I range	1.2		5.5	V
η Efficiency	$I_O = I_O\text{ max}$	$R_{SET} = 280\text{ }\Omega$, $V_O = 5\text{ V}$		92%		
		$R_{SET} = 2.0\text{ k}\Omega$, $V_O = 3.3\text{ V}$		90%		
		$R_{SET} = 4.32\text{ k}\Omega$, $V_O = 2.5\text{ V}$		88%		
		$R_{SET} = 11.5\text{ k}\Omega$, $V_O = 1.8\text{ V}$		85%		
		$R_{SET} = 24.3\text{ k}\Omega$, $V_O = 1.5\text{ V}$		83%		
		$R_{SET} = \text{open cct.}$, $V_O = 1.2\text{ V}$		80%		
Output voltage ripple (peak-to-peak)	20-MHz bandwidth		20		mV _{PP}	
I_O (trip) Overcurrent threshold	Reset, followed by auto-recovery		16		A	
Transient response	1-A/ μs load step, 50 to 100% I_O max, $C_3 = 100\text{ }\mu\text{F}$ Recovery time V_O over/undershoot		70		μs	
			100		mV	
Track control (pin 5)	I_{IL} Input low current	Pin to GND		-0.13	mA	
	Control slew-rate limit	$C_3 \leq C_3$ (max)		1	V/ms	
UVLO Undervoltage lockout	V_I increasing		9.5	10.4	V	
	V_I decreasing		8.8	9		
Inhibit control (pin 7)	V_{IH} Input high voltage	Referenced to GND		Open ⁽³⁾	V	
	V_{IL} Input low voltage		-0.2	0.6		
	I_{IL} Input low current	Pin to GND		-0.24	mA	
I_I (stby) Input standby current	Inhibit (pin 7) to GND, Track (pin 5) open		10		mA	
f_S Switching frequency	Over V_I and I_O ranges	250	325	400	kHz	
External input capacitance	Nonceramic (C1)	100 ⁽⁴⁾			μF	
	Ceramic (C2)	10 ⁽⁴⁾				
External output capacitance (C3)	Capacitance value	Nonceramic	0	100 ⁽⁵⁾ 3,300 ⁽⁶⁾	μF	
		Ceramic	0	300		
	Equivalent series resistance (nonceramic)		4 ⁽⁷⁾			m Ω
MTBF Reliability	Per Telcordia SR-332, 50% stress, $T_A = 40^\circ\text{C}$, ground benign	5			10^6 Hrs	

- (1) See thermal derating curves for safe operating area (SOA), or consult factory for appropriate derating.
- (2) The set-point voltage tolerance is affected by the tolerance and stability of R_{SET} . The stated limit is unconditionally met if R_{SET} has a tolerance of 1%, with 100 ppm/ $^\circ\text{C}$ or better temperature stability.
- (3) This control pin is pulled up to an internal supply voltage. To avoid risk of damage to the module, *do not* apply an external voltage greater than 7 V. If this input is left open-circuit, the module operates when input power is applied. A small low-leakage (<100 nA) MOSFET is recommended for control. For further information, consult the related application note.
- (4) A 10- μF high-frequency ceramic capacitor and 100- μF electrolytic input capacitor are required for proper operation. The electrolytic capacitor must be rated for the minimum ripple current rating. See the application information for further guidance on input capacitor selection.
- (5) An external output capacitor is not required for basic operation. Adding 100 μF of distributed capacitance at the load improves the transient response.
- (6) This is the calculated maximum. The minimum ESR limitation often results in a lower value. See the application information for further guidance.
- (7) This is the typical ESR for all the electrolytic (nonceramic) output capacitance. Use 7 m Ω as the minimum when using max-ESR values to calculate.

ELECTRICAL CHARACTERISTICS

operating at 25°C free-air temperature, $V_I = 12\text{ V}$, $V_O = 1.8\text{ V}$, $C_1 = 100\text{ }\mu\text{F}$, $C_2 = 10\text{ }\mu\text{F}$, $C_3 = 0\text{ }\mu\text{F}$, and $I_O = I_O\text{ max}$ (unless otherwise noted)

PARAMETER	TEST CONDITIONS	PTV12010L			UNIT
		MIN	TYP	MAX	
I_O	Output current	Natural convection airflow			A
V_I	Input voltage range	Over I_O load range			V
V_O	Set-point voltage tolerance				$\pm 2\%$ (2)
	Temperature variation	$-40^\circ\text{C} < T_A < 85^\circ\text{C}$			$\pm 0.5\%$
	Line regulation	Over V_I range			± 10
	Load regulation	Over I_O range			± 12
	Total output variation	Includes set-point, line, load, $-40^\circ\text{C} \leq T_A \leq 85^\circ\text{C}$			± 3 (2)
	Adjust range	Over V_I range			0.8 1.8
η	Efficiency	$I_O = I_O\text{ max}$	$R_{SET} = 130\text{ }\Omega$, $V_O = 1.8\text{ V}$		87%
			$R_{SET} = 3.57\text{ k}\Omega$, $V_O = 1.5\text{ V}$		86%
			$R_{SET} = 12.1\text{ k}\Omega$, $V_O = 1.2\text{ V}$		84%
			$R_{SET} = 32.4\text{ k}\Omega$, $V_O = 1\text{ V}$		81%
			$R_{SET} = \text{open cct.}$, $V_O = 0.8\text{ V}$		78%
	Output voltage ripple (pk-pk)	20-MHz bandwidth			mV _{PP}
I_O (trip)	Overcurrent threshold	Reset, followed by auto-recovery			A
	Transient response	1-A/ μs load step, 50 to 100% I_O max, $C_3 = 100\text{ }\mu\text{F}$			
		Recovery time			70
		V_O over/undershoot			100
Track control (pin 5)	I_{IL} Input low current	Pin to GND			-0.13
	Control slew-rate limit	$C_3 \leq C_3$ (max)			1
Inhibit control (pin 7)	V_{IH} Input high voltage	Referenced to GND			Open (3)
	V_{IL} Input low voltage				-0.2 0.6
	I_{IL} Input low current	Pin to GND			-0.24
I_I (stby)	Input standby current	Inhibit (pin 7) to GND, Track (pin 5) open			10
UVLO	Undervoltage lockout	V_I increasing			9.5 10.4
		V_I decreasing			8.8 9
f_S	Switching frequency	Over V_I and I_O ranges			200 250 300
	External input capacitance	Nonceramic (C1)			100 (4)
		Ceramic (C2)			10 (4)
	External output capacitance (C3)	Capacitance value	Nonceramic		0 100 (5) 3,300 (6)
			Ceramic		0 300
		Equivalent series resistance (nonceramic)		4 (7)	
MTBF	Reliability	Per Telcordia SR-332, 50% stress, $T_A = 40^\circ\text{C}$, ground benign			10^6 Hrs

- (1) See thermal derating curves for safe operating area (SOA), or consult factory for appropriate derating.
- (2) The set-point voltage tolerance is affected by the tolerance and stability of R_{SET} . The stated limit is unconditionally met if R_{SET} has a tolerance of 1%, with 100 ppm/ $^\circ\text{C}$ or better temperature stability.
- (3) This control pin is pulled up to an internal supply voltage. To avoid risk of damage to the module, *do not* apply an external voltage greater than 7 V. If this input is left open-circuit, the module operates when input power is applied. A small low-leakage (<100 nA) MOSFET is recommended for control. For further information, consult the related application note.
- (4) A 10- μF high-frequency ceramic capacitor and 100- μF electrolytic input capacitor are required for proper operation. The electrolytic capacitor must be rated for the minimum ripple current rating. Consult the Application Information for guidance on input capacitor selection.
- (5) An external output capacitor is not required for basic operation. Adding 100 μF of distributed capacitance at the load improves the transient response.
- (6) This is the calculated maximum. The minimum ESR limitation often results in a lower value. Consult the Application Information for further guidance.
- (7) This is the typical ESR for all the electrolytic (nonceramic) output capacitance. Use 7 m Ω as the minimum when using max-ESR values to calculate.

PTV12010W Characteristic Data; 1.2 V to 5.5 V⁽⁸⁾⁽⁹⁾

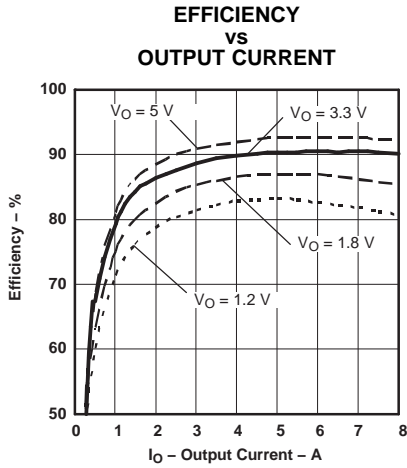

Figure 1.

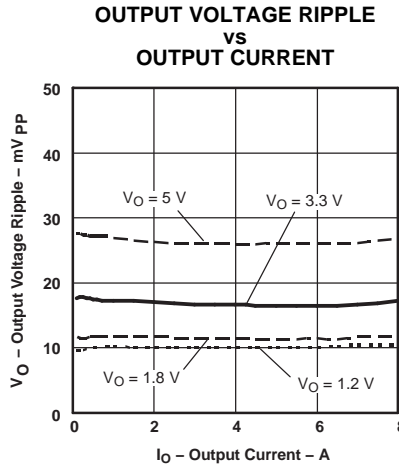

Figure 2.

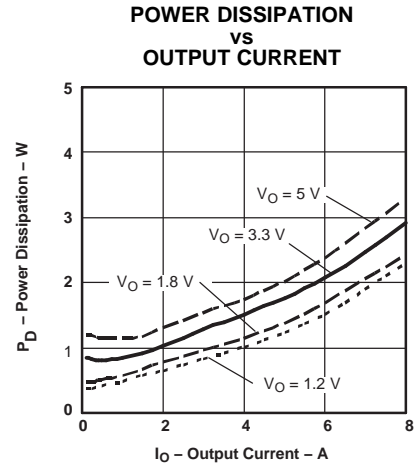

Figure 3.

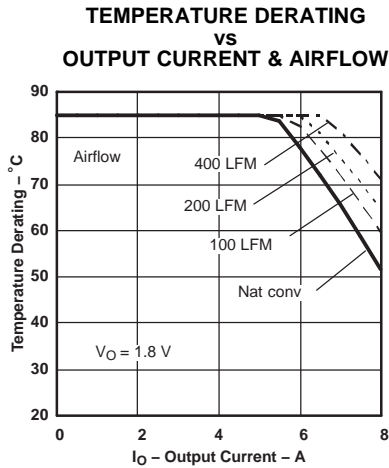

Figure 4.

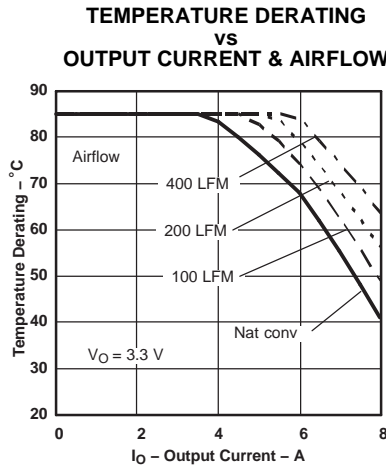

Figure 5.

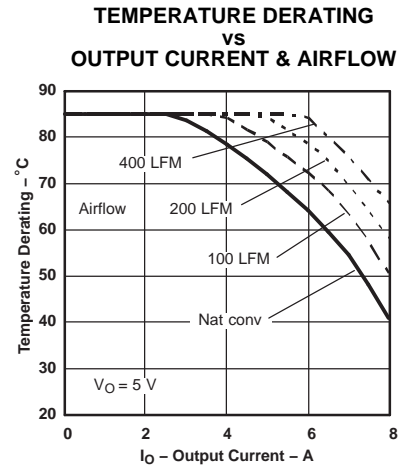

Figure 6.

- (8) The electrical characteristic data has been developed from actual products tested at 25°C. This data is considered typical for the converter. Applies to [Figure 1](#), [Figure 2](#), and [Figure 3](#).
- (9) The temperature derating curves represent the conditions at which internal components are at or below the manufacturer's maximum operating temperatures. Derating limits apply to modules soldered directly to a 100 mm x 100 mm double-sided PCB with 2 oz. copper. Applies to [Figure 4](#), [Figure 5](#), and [Figure 6](#).

PTV12010L Characteristic Data; 0.8 V to 1.8 V⁽¹⁰⁾⁽¹¹⁾

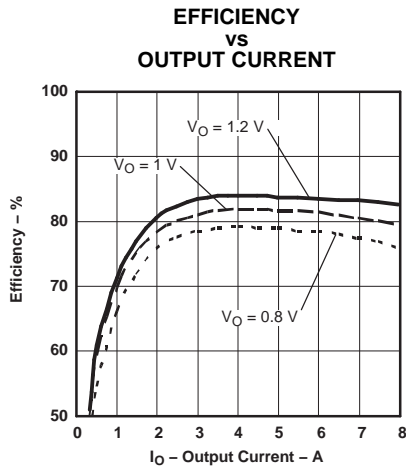

Figure 7.

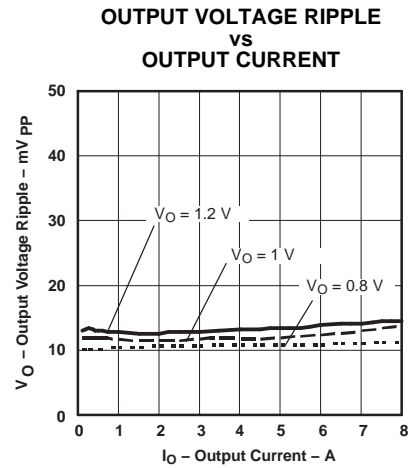

Figure 8.

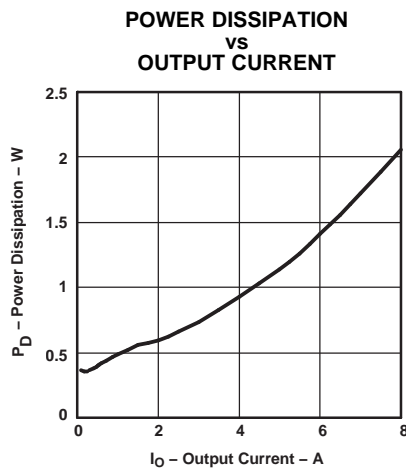

Figure 9.

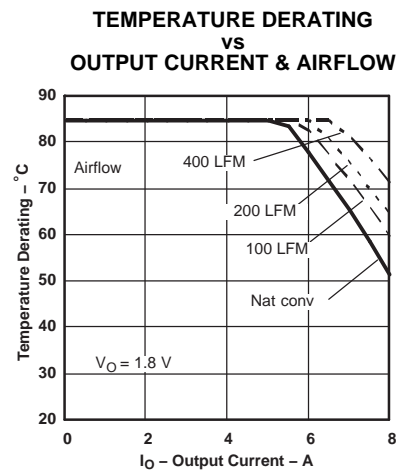

Figure 10.

- (10) The electrical characteristic data has been developed from actual products tested at 25°C. This data is considered typical for the converter. Applies to [Figure 7](#), [Figure 8](#), and [Figure 9](#).
- (11) The temperature derating curves represent the conditions at which internal components are at or below the manufacturer's maximum operating temperatures. Derating limits apply to modules soldered directly to a 100 mm x 100 mm double-sided PCB with 2 oz. copper. Applies to [Figure 10](#).

DEVICE INFORMATION
TERMINAL FUNCTIONS

TERMINAL		DESCRIPTION
NAME	NO.	
V_I	8	The positive input voltage power node to the module, which is referenced to common GND.
V_O	2, 3	The regulated positive power output with respect to the GND node.
GND	1, 6	This is the common ground connection for the V_I and V_O power connections. It is also the 0 VDC reference for the control inputs.
Inhibit	7	The Inhibit pin is an open-collector/drain, active-low input that is referenced to GND. Applying a low-level ground signal to this input disables the module's output and turns off the output voltage. When the Inhibit control is active, the input current drawn by the regulator is significantly reduced. If the inhibit feature is not used, the control pin should be left open-circuit. The module then produces an output voltage whenever a valid input source is applied. Do not place an external pull-up on this pin. <i>For power-up into a non-prebiased output, it is recommended that AutoTrack be utilized for On/Off control. See the Application Information for additional details.</i>
V_O Adjust	4	A 1% resistor must be connected directly between this pin and GND (pin 1) to set the output voltage of the module higher than its lowest value. The temperature stability of the resistor should be 100 ppm/°C (or better). The set-point range is 1.2 V to 5.5 V for W-suffix devices and 0.8 V to 1.8 V for L-suffix devices. The resistor value required for a given output voltage may be calculated using a formula. If left open-circuit, the module output voltage defaults to its lowest value. For further information on output voltage adjustment, consult the related application note. The specification table gives the standard resistor values for a number of common output voltages.
Track	5	This is an analog control input that enables the output voltage to follow an external voltage. This pin becomes active typically 20 ms after the input voltage has been applied, and allows direct control of the output voltage from 0 V up to the nominal set-point voltage. Within this range, the output follows the voltage at the Track pin on a volt-for-volt basis. When the control voltage is raised above this range, the module regulates at its set-point voltage. The feature allows the output voltage to rise simultaneously with other modules powered from the same input bus. If unused, this input should be connected to V_I . <i>NOTE: Due to the undervoltage lockout feature, the output of the module cannot follow its own input voltage during power up. Consult the related Application Information for further guidance.</i>

APPLICATION INFORMATION

ADJUSTING THE OUTPUT VOLTAGE

The V_O Adjust control (pin 8) sets the output voltage of the PTV12010 product. The adjustment range is from 1.2 V to 5.5 V for the W-suffix modules and 0.8 V to 1.8 V for L-suffix modules. The adjustment method requires the addition of a single external resistor, R_{SET} , that must be connected directly between the V_O Adjust and GND (pin 1 or 2). [Table 1](#) gives the standard value of the external resistor for a number of standard voltages, along with the actual output voltage that this resistance value provides. For other output voltages, the value of the required resistor can either be calculated using [Equation 1](#) or simply selected from the range of values given in [Table 3](#). [Figure 11](#) shows the placement of the required resistor.

Table 1. Standard Values of R_{SET} for Common Output Voltages

V_O (V) (Required)	PTV12010W		PTV12010L	
	R_{SET} (k Ω) (Standard Value)	V_O (V) (Actual)	R_{SET} (k Ω) (Standard Value)	V_O (V) (Actual)
5	0.280	5.009	N/A	N/A
3.3	2.0	3.294	N/A	N/A
2.5	4.32	2.503	N/A	N/A
2	8.06	2.010	N/A	N/A
1.8	11.5	1.801	0.130	1.800
1.5	24.3	1.506	3.57	1.499
1.2	Open	1.200	12.1	1.201
1.1	N/A	N/A	18.7	1.101
1.0	N/A	N/A	32.4	0.999
0.9	N/A	N/A	71.5	0.901
0.8	N/A	N/A	Open	0.800

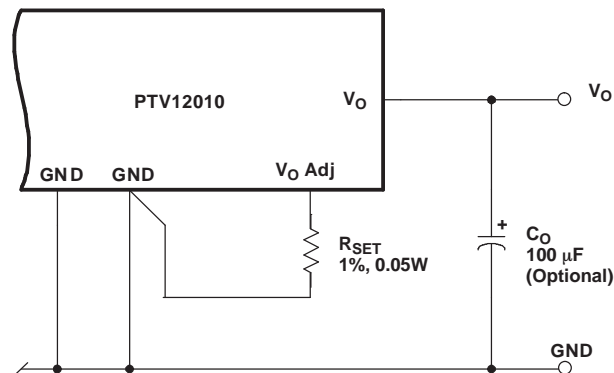

- (1) A 0.05-W rated resistor may be used. The tolerance should be 1%, with temperature stability of 100 ppm/ $^{\circ}$ C (or better). Place the resistor as close to the regulator as possible. Connect the resistor directly between pin 8 and pins 1 or 2, using dedicated PCB traces.
- (2) Never connect capacitors from V_O Adj to either GND or V_O . Any capacitance added to the V_O Adj pin affects the stability of the regulator.

Figure 11. V_O Adjust Resistor Placement

Use [Equation 1](#) to calculate the adjust resistor value. See [Table 2](#) for parameters, R_s and V_{min} .

Equation 1. Output Voltage Adjust

$$R_{set} = 10 \text{ k}\Omega \times \frac{0.8 \text{ V}}{V_{out} - V_{min}} - R_s \text{ k}\Omega \quad (1)$$

Table 2. Adjust Formula Parameters

PARAMETER	PART NUMBER	
	PTV12010W	PTV12010L
V_{min} (V)	1.2	0.8
V_{max} (V)	5.5	1.8
R_s (k Ω)	1.82	7.87

Table 3. Calculated Values of R_{SET} for Other Output Voltages

PTV12010W				PTV12010L	
V_{OUT} (V)	R_{SET} (k Ω)	V_{OUT} (V)	R_{SET} (k Ω)	V_{OUT} (V)	R_{SET} (k Ω)
1.200	Open	2.70	3.51	0.800	Open
1.250	158.0	2.80	3.18	0.825	312.0
1.300	78.2	2.90	2.89	0.850	152.0
1.350	51.5	3.00	2.62	0.875	98.8
1.400	38.2	3.10	2.39	0.900	72.1
1.450	30.2	3.20	2.18	0.925	56.1
1.50	24.8	3.30	1.99	0.950	45.5
1.55	21.0	3.40	1.82	0.975	37.8
1.60	18.2	3.50	1.66	1.000	32.1
1.65	16.0	3.60	1.51	1.025	27.7
1.70	14.2	3.70	1.38	1.050	24.1
1.75	12.7	3.80	1.26	1.075	21.2
1.80	11.5	3.90	1.14	1.100	18.8
1.85	10.5	4.00	1.04	1.125	16.7
1.90	9.61	4.10	0.939	1.150	15.0
1.95	8.85	4.20	0.847	1.175	13.5
2.00	8.18	4.30	0.761	1.200	12.1
2.05	7.59	4.40	0.680	1.250	9.91
2.10	7.07	4.50	0.604	1.300	8.13
2.15	6.60	4.60	0.533	1.350	6.68
2.20	6.18	4.70	0.466	1.400	5.46
2.25	5.80	4.80	0.402	1.450	4.44
2.30	5.45	4.90	0.342	1.50	3.56
2.35	5.14	5.00	0.285	1.55	2.8
2.40	4.85	5.10	0.231	1.60	2.13
2.45	4.58	5.20	0.180	1.65	1.54
2.50	4.33	5.30	0.131	1.70	1.02
2.55	4.11	5.40	0.085	1.75	0.551
2.60	3.89	5.50	0.041	1.80	0.130
2.65	3.70				

Capacitor Recommendations for the PTV12010 Series of Power Modules

Input Capacitors

The required input capacitors are a combination of a 10- μ F X5R/X7R ceramic, and a 100- μ F electrolytic type. When $V_O > 3$ V the 100- μ F electrolytic capacitance must be rated for 700 mArms ripple current capability. For $V_O \leq 3$ V, the ripple current rating must be at least 450 mArms. Where applicable, [Table 4](#) gives the maximum output voltage and current limits for a capacitor's rms ripple current rating. The ripple current requirements for the electrolytic capacitance are *conditional* that the 10- μ F ceramic capacitor is present.

The 10- μ F ceramic capacitor is necessary to reduce both the magnitude of ripple current through the electrolytic capacitor and the amount of ripple current reflected back to the input source. Ceramic capacitors should be located within 0.5 in. (1,3 cm) of the module input pins. Additional ceramic capacitors can be added to reduce the RMS ripple current requirement for the electrolytic capacitor.

Ripple current (Arms) rating, less than 100 m Ω of equivalent series resistance (ESR), and temperature are the major considerations when selecting input capacitors. Regular tantalum capacitors have a recommended minimum voltage rating of $2 \times$ (max. dc voltage + ac ripple). This is standard practice to ensure reliability. Only a few tantalum capacitors were found to have sufficient voltage rating to meet this requirement. At temperatures below 0°C, the ESR of aluminum electrolytic capacitors increases. For these applications Os-Con, polymer-tantalum, and polymer-aluminum types should be considered.

Output Capacitor (Optional)

For applications with load transients (sudden changes in load current), regulator response benefits from external output capacitance. The optional value defined is only required to meet the transient response specification. For most applications, a high-quality computer-grade aluminum electrolytic capacitor is adequate. These capacitors provide decoupling over the frequency range, 2 kHz to 150 kHz, and are suitable when ambient temperatures are above 0°C. For operation below 0°C, tantalum, ceramic, or Os-Con type capacitors are recommended. When using one or more nonceramic capacitors, the calculated equivalent ESR should be no lower than 4 m Ω (7 m Ω using the manufacturer's maximum ESR for a single capacitor). A list of preferred low-ESR type capacitors are identified in [Table 4](#).

In addition to electrolytic capacitance, adding a 10- μ F ceramic capacitor across the output will further reduce the output ripple voltage and improve the regulator's transient response. The measurement of both the output ripple and transient response is also best achieved across a 10- μ F ceramic capacitor.

Ceramic Capacitors

Above 150 kHz, the performance of aluminum electrolytic capacitors is less effective. Multilayer ceramic capacitors have low ESR and a resonant frequency higher than the bandwidth of the regulator. They are recommended to reduce the reflected ripple current at the input as well as improve the transient response of the output. When used on the output their combined ESR is not critical as long as the total value of ceramic capacitance does not exceed approximately 300 μ F. Also, to prevent the formation of local resonances, do not place more than five identical ceramic capacitors in parallel with values of 10 μ F or greater.

Tantalum Capacitors

Tantalum-type capacitors can only be used on the output bus, and are recommended for applications where the ambient operating temperature can be less than 0°C. The AVX TPS, Sprague 593D/594/595 and Kemet T495/T510 capacitor series are suggested over many other tantalum types due to their higher rated surge, power dissipation, and ripple current capability. As a caution, many general-purpose tantalum capacitors have considerably higher ESR, reduced power dissipation and lower ripple current capability. These capacitors are also less reliable as they have reduced power dissipation and surge current ratings. Tantalum capacitors that have no stated ESR or surge current rating are not recommended for power applications.

When specifying Os-con and polymer tantalum capacitors for the output, the minimum ESR limit is encountered before the maximum capacitance value is reached.

Capacitor Table

Table 4 identifies the characteristics of capacitors from a number of vendors with acceptable ESR and ripple current (rms) ratings. The recommended number of capacitors required at both the input and output buses is identified for each capacitor type.

Note: This is not an extensive capacitor list. Capacitors from other vendors are available with comparable specifications. Those listed are for guidance. The RMS ripple current rating and ESR (at 100 kHz) are critical parameters necessary to ensure both optimum regulator performance and long capacitor life.

Table 4. Input/Output Capacitors

Capacitor Vendor, Type/Series (Style)	Capacitor Characteristics					Quantity		Vendor Part Number
	Working Voltage (V)	Value (μ F)	Max ESR at 100 kHz (Ω)	Max. Irms Ripple Current at 85°C (mA)	Physical Size (mm)	Input Bus	Optional Output Bus	
Panasonic, Aluminum	25	330	0.090	755	10 x 12.5	1	1	EEUFC1E331
FC (Radial)	35	180	0.090	755	10 x 12.5	1	1	EEUFC1V181
FK (SMD)	25	470	0.080	850	10 x 10.2	1	1	EEVFK1E471P
United Chemi-Con PXA, Poly-Aluminum (SMD)	16	150	0.026	3430	10 x 7.7	1	≤ 4	PXA16VC151MJ80TP
FP, Os-con (Radial)	20	120	0.024	3100	8 x 10.5	1	≤ 4	20FP120MG
FS, OS-con (SMD)	20	100	0.030	2740	8 x 10.5	1	≤ 4	20FS100M
LXZ, Aluminum (Radial)	35	220	0.090	760	10 x 12.5	1	1	LXZ35VB221M10X12LL
Nichicon, Aluminum HD (Radial)	25	220	0.072	760	8 x 11.5	1	1	UHD1E221MPR
PM (Radial)	35	220	0.090	770	10 x 15	1	1	UPM1V221MHH6
Panasonic, Poly-Aluminum WA (SMD)	16	100	0.039	2500	8 x 6.9	1	≤ 5	EEFWA1C101P
S/SE (SMD)	6.3 ⁽¹⁾	180	0.005	4000	7.3 x 4.3 x 4.2	N/R ⁽²⁾	≤ 1	EEFSE0J181R (V _O \leq 5.1V)
Sanyo SVP, Os-Con (SMD)	20	100	0.024	>3300	8 x 12	1	≤ 4	20SVP100M
SP, Os-Con	20	120	0.024	>3100	8 x 10.5	1	≤ 4	20SP120M
TPE, Pos-cap (SMD)	10	220	0.025	>2400	7.3 x 5.7	1	≤ 4	10TPE220ML
AVX, Tantalum, TPS (SMD)	10	100	0.100	>1090	7.3x 5.7x4.1	N/R ⁽²⁾	≤ 5	TPSD107M010R0100
	10	220	0.100	>1414	7.3x 5.7x4.1	N/R ⁽²⁾	≤ 5	TPSV227M010R0100
	25	68	0.095	>1451	7.3x 5.7x4.1	2	≤ 5	TPSV686M025R0095
Kemet (SMD) T520, Poly-Tant (SMD)	10	100	0.080	1200	7.3x5.7x4	N/R ⁽²⁾	≤ 5	T520D107M010AS
T495, Tantalum (SMD)	10	100	0.100	>1100	7.3x5.7x4	N/R ⁽²⁾	≤ 1	T495X107M010AS
Vishay-Sprague 594D, Tantalum (SMD)	10	150	0.090	1100	7.3x6x4.1	N/R ⁽²⁾	≤ 5	594D157X0010C2T
	25	68	0.095	1600	7.3x6x4.1	2	≤ 5	594D686X0025R2T
94SP, Organic (Radial)	16	100	0.075	2890	10 x 10.5	1	≤ 2	94SP107X0016FBP
Kemet, Ceramic X5R (SMD)	16	10	0.002	—		≥ 1 ⁽³⁾	≤ 5	C1210C106M4PAC
	6.3	47	0.002		3225 mm	N/R ⁽²⁾	≤ 5	C1210C476K9PAC
Murata, Ceramic X5R (SMD)	6.3	100				N/R ⁽²⁾	≤ 3	GRM32ER60J107M
	6.3	47	0.002	—	3225 mm	N/R ⁽²⁾	≤ 5	GRM32ER60J476M
	16	22				≥ 1 ⁽³⁾	≤ 5	GRM32ER61C226K
	16	10				≥ 1 ⁽³⁾	≤ 5	GRM32DR61C106K
TDK, Ceramic X5R (SMD)	6.3	100				N/R ⁽²⁾	≤ 3	C3225X5R0J107MT
	6.3	47	0.002	—	3225 mm	N/R ⁽²⁾	≤ 5	C3225X5R0J476MT
	16	22				≥ 1 ⁽³⁾	≤ 5	C3225X5R1C226MT
	16	10				≥ 1 ⁽³⁾	≤ 5	C3225X5R1C106MT

(1) The voltage rating of this capacitor only allows it to be used for output voltages that are equal to, or less than, 5.1 V.

(2) N/R – Not recommended. The voltage rating does not meet the minimum operating limits.

(3) Ceramic capacitors are required to complement electrolytic types at the input and to reduce high-frequency ripple current.

Designing for Fast Load Transients

The transient response of the dc/dc converter has been characterized using a load transient with a di/dt of 1 A/μs. The typical voltage deviation for this load transient is given in the data sheet specification table using the optional value of output capacitance. As the di/dt of a transient is increased, the response of a converter regulation circuit ultimately depends on its output capacitor decoupling network. This is an inherent limitation with any dc/dc converter once the speed of the transient exceeds its bandwidth capability. If the target application specifies a higher di/dt or lower voltage deviation, the requirement can only be met with additional output capacitor decoupling. In these cases special attention must be paid to the type, value and ESR of the capacitors selected.

Features of the PTH Family of Non-Isolated Wide Output Adjust Power Modules

Introduction

The PTH/PTV family of non-isolated, wide-output adjustable power modules are optimized for applications that require a flexible, high performance module that is small in size. Each of these products are POLA™ compatible. POLA-compatible products are produced by a number of manufacturers, and offer customers advanced, nonisolated modules with the same footprint and form factor. POLA parts are also ensured to be interoperable, thereby, providing customers with second-source availability.

From the basic, *Just Plug it In* functionality of the 6-A modules, to the 30-A rated feature-rich PTHxx030, these products were designed to be very flexible, yet simple to use. The features vary with each product. Table 5 provides a quick reference to the features by product series and input bus voltage.

Table 5. Operating Features by Series and Input Bus Voltage

Series	Input Bus (V)	I _o (A)	Adjust (Trim)	On/Off Inhibit	Over-Current	Prebias Startup	Auto-Track™	Margin Up/Down	Output Sense	Thermal Shutdown
PTHxx050	3.3	6	•	•	•	•	•			
	5	6	•	•	•	•	•			
	12	6	•	•	•	•	•			
PTHxx060	3.3 / 5	10	•	•	•	•	•	•	•	
	12	8	•	•	•	•	•	•	•	
PTHxx010	3.3 / 5	15	•	•	•	•	•	•	•	
	12	12	•	•	•	•	•	•	•	
PTVxx010	5	8	•	•	•	•	•			
	12	8	•	•	•	•	•			
PTHxx020	3.3 / 5	22	•	•	•	•	•	•	•	•
	12	18	•	•	•	•	•	•	•	•
PTVxx020	5	18	•	•	•	•	•		•	•
	12	16	•	•	•	•	•		•	•
PTHxx030	3.3 / 5	30	•	•	•	•	•	•	•	•
	12	26	•	•	•	•	•	•	•	•

For simple point-of-use applications, the PTH12050 (6A) provides operating features such as an on/off inhibit, output voltage trim, prebias start-up and overcurrent protection. The PTH12060 (10A), and PTH12010 (12A) include an output voltage sense, and margin up/down controls. Then the higher output current, PTH12020 (18A) and PTH12030 (26A) products incorporate overtemperature shutdown protection.

The PTV12010 and PTV12020 are similar parts offered in a vertical, single in-line pin (SIP) profile, at slightly lower current ratings.

All of the products referenced in [Table 5](#) include Auto-Track™. This feature was specifically designed to simplify the task of sequencing the supply voltages in a power system. This and other features are described in the following sections.

POWER-UP INTO A NON-PREBIASED OUTPUT — AUTO-TRACK™ FUNCTION

The Auto-Track function is unique to the PTH/PTV family, and is available with all POLA products. Auto-Track was designed to simplify the amount of circuitry required to make the output voltage from each module power up and power down in sequence. The sequencing of two or more supply voltages during power up is a common requirement for complex mixed-signal applications that use dual-voltage VLSI ICs such as the TMS320™ DSP family, microprocessors, and ASICs.

Basic Power-Up using Auto-Track™

For applications requiring output voltage on/off control, each series of the PTH family incorporates the track control pin. The Auto-Track feature should be used instead of the inhibit feature wherever there is a requirement for the output voltage from the regulator to be turned on/off.

Figure 12 shows the typical application for basic start-up. Note the discrete transistor (Q1). The track input has its own internal pull-up to a potential of 5 V to 13.2 V. The input is not compatible with TTL logic devices. An open-collector (or open-drain) discrete transistor or supply voltage supervisor (TPS3808 or TPS7712) is recommended for control.

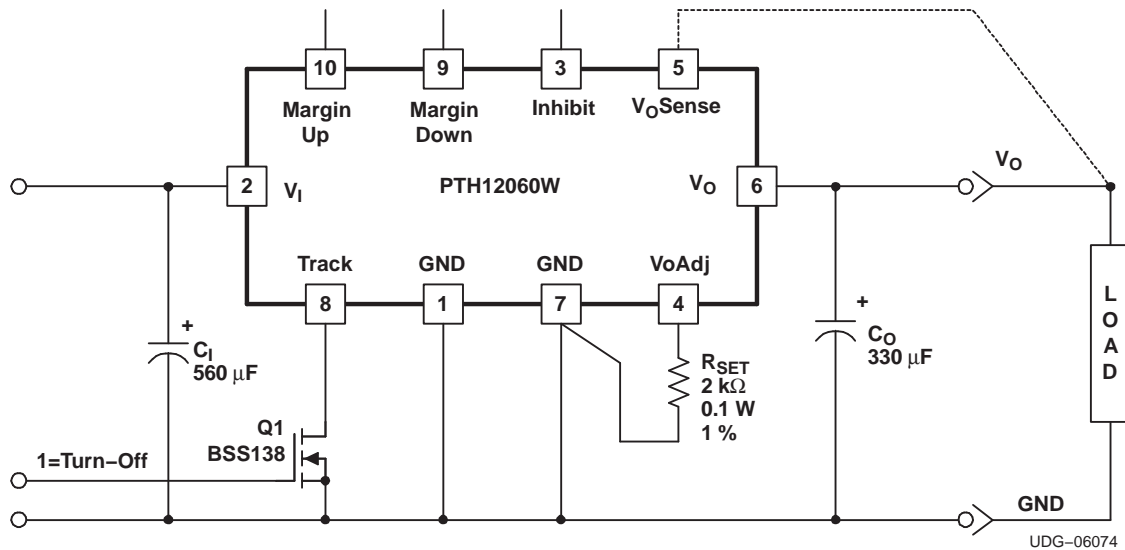

Figure 12. Basic Start-up Control Circuit

Turning on Q1 applies a low voltage to the track control pin and disables the output of the module. If Q1 is then turned off, the output ramps immediately to the regulated output voltage. A regulated output voltage is produced within 35 ms. With the initial application of the input source voltage, the track pin must be held low (Q1 turned ON) for at least 40 ms. Figure 13 shows the typical rise in both the output voltage and input current, following the turn off of Q1. The turn off of Q1 corresponds to the rise in the waveform, Q1 Vds. The waveforms were measured with a 10-A constant current load.

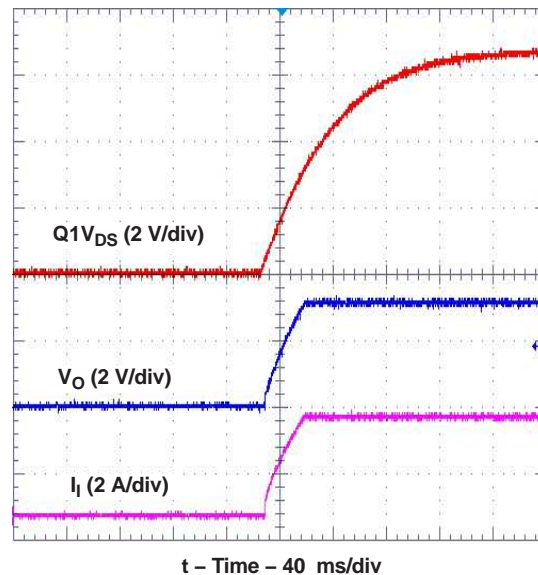

Figure 13. Power-Up from Track Control

NOTE:

If a prebias condition is not present, it is highly recommended that the Track control pin be used for controlled power-up and power-down. If Track control is not used, the output voltage starts up and overshoots by as much as 10%, before settling at the output voltage setpoint.

How Auto-Track™ Works

Auto-Track works by forcing the module output voltage to follow a voltage presented at the *Track* control pin ⁽¹⁾. This control range is limited to between 0 V and the module set-point voltage. Once the track-pin voltage is raised above the set-point voltage, the module output remains at its set-point ⁽²⁾. As an example, if the *Track* pin of a 2.5-V regulator is at 1 V, the regulated output is 1 V. If the voltage at the *Track* pin rises to 3 V, the regulated output does not go higher than 2.5 V.

When under Auto-Track control, the regulated output from the module follows the voltage at its *Track* pin on a volt-for-volt basis. By connecting the *Track* pin of a number of these modules together, the output voltages follow a common signal during power up and power down. The control signal can be an externally generated master ramp waveform, or the output voltage from another power supply circuit ⁽³⁾. For convenience, the *Track* input incorporates an internal RC-charge circuit. This operates off the module input voltage to produce a suitable rising waveform at power up.

Typical Auto-Track Application

The basic implementation of Auto-Track allows for simultaneous voltage sequencing of a number of Auto-Track compliant modules. Connecting the *Track* inputs of two or more modules forces their track input to follow the same collective RC-ramp waveform, and allows their power-up sequence to be coordinated from a common Track control signal. This can be an open-collector (or open-drain) device, such as a power-up reset voltage supervisor IC. See U3 in [Figure 14](#).

To coordinate a power-up sequence, the Track control must first be pulled to ground potential through R_{TRK} as defined in [Figure 14](#). This should be done at or before input power is applied to the modules. The ground signal should be maintained for at least 40 ms after input power has been applied. This brief period gives the modules time to complete their internal soft-start initialization⁽⁴⁾, enabling them to produce an output voltage. A low-cost supply voltage supervisor IC, that includes a built-in time delay, is an ideal component for automatically controlling the Track inputs at power up.

[Figure 14](#) shows how the TL7712A supply voltage supervisor IC (U3) can be used to coordinate the sequenced power up of two 12-V input Auto-Track modules. The output of the TL7712A supervisor becomes active above an input voltage of 3.6 V, enabling it to assert a ground signal to the common track control well before the input voltage has reached the module's undervoltage lockout threshold. The ground signal is maintained until approximately 43 ms after the input voltage has risen above U3's voltage threshold, which is 10.95 V. The 43-ms time period is controlled by the capacitor C3. The value of 3.3 μ F provides sufficient time delay for the modules to complete their internal soft-start initialization. The output voltage of each module remains at zero until the track control voltage is allowed to rise. When U3 removes the ground signal, the track control voltage automatically rises. This causes the output voltage of each module to rise simultaneously with the other modules, until each reaches its respective set-point voltage.

[Figure 15](#) shows the output voltage waveforms from the circuit of [Figure 14](#) after input voltage is applied to the circuit. The waveforms, V_{O1} and V_{O2} , represent the output voltages from the two power modules, U1 (3.3 V) and U2 (1.8 V), respectively. V_{TRK} , V_{O1} , and V_{O2} are shown rising together to produce the desired simultaneous power-up characteristic.

The same circuit also provides a power-down sequence. When the input voltage falls below U3's voltage threshold, the ground signal is re-applied to the common track control. This pulls the track inputs to zero volts, forcing the output of each module to follow, as shown in [Figure 16](#). In order for a simultaneous power-down to occur, the track inputs must be pulled low before the input voltage has fallen below the modules' undervoltage lockout. This is an important constraint. Once the modules recognize that a valid input voltage is no longer present, their outputs can no longer follow the voltage applied at their track input. During a power-down sequence, the fall in the output voltage from the modules is limited by the maximum output capacitance and the Auto-Track slew rate. If the *Track* pin is pulled low at a slew rate greater than 1 V/ms, the discharge of the output capacitors will induce large currents which could exceed the peak current rating of the module. This will result in a reduction in the maximum allowable output capacitance as listed in the Electrical Characteristics table. When controlling the *Track* pin of the PTH12060W using a voltage supervisor IC, the slew rate is increased, therefore C_{Omax} is reduced to 2200 μ F.

Notes on Use of Auto-Track™

1. The *Track* pin voltage must be allowed to rise above the module set-point voltage before the module regulates at its adjusted set-point voltage.
2. The Auto-Track function tracks almost any voltage ramp during power up, and is compatible with ramp speeds of up to 1 V/ms.
3. The absolute maximum voltage that may be applied to the *Track* pin is the input voltage V_i .
4. The module cannot follow a voltage at its track control input until it has completed its soft-start initialization. This takes about 40 ms from the time that a valid voltage has been applied to its input. During this period, it is recommended that the *Track* pin be held at ground potential.
5. The Auto-Track function is disabled by connecting the *Track* pin to the input voltage (V_i). When Auto-Track is disabled, the output voltage rises at a quicker and more linear rate after input power has been applied.

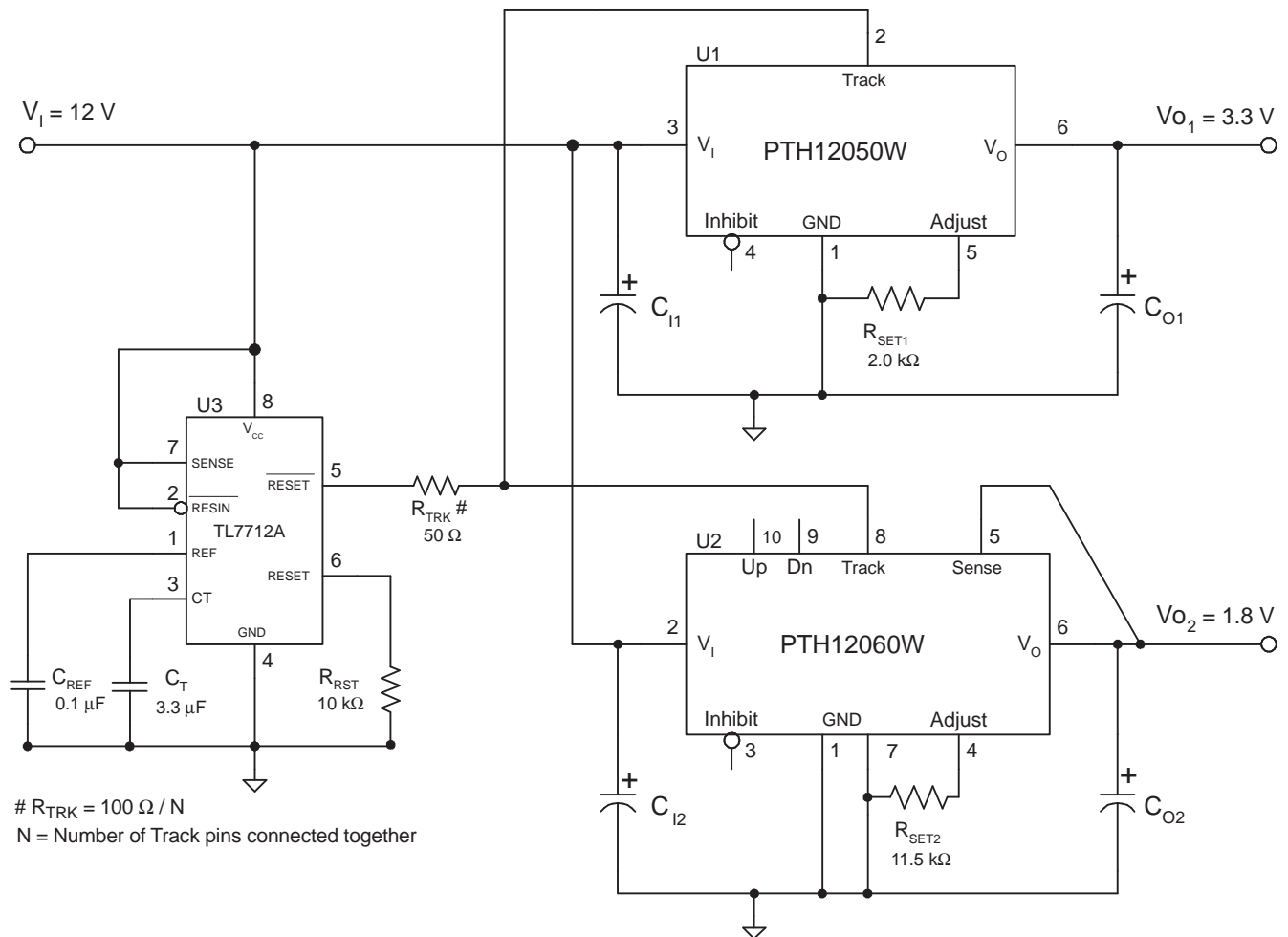

Figure 14. Sequenced Power Up and Power Down Using Auto-Track

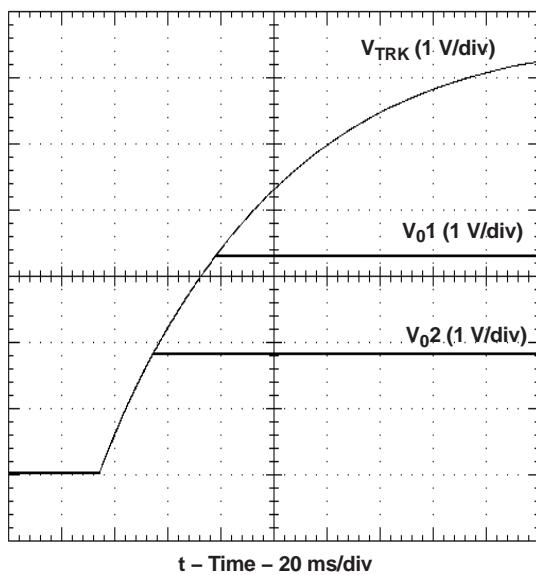

Figure 15. Simultaneous Power Up With Auto-Track Control

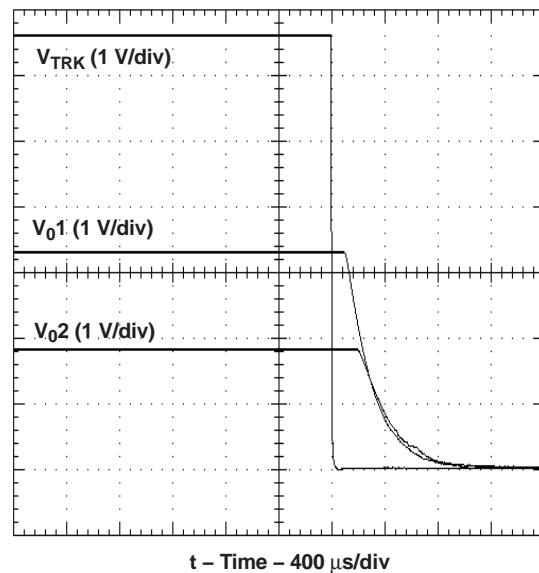

Figure 16. Simultaneous Power Down with Auto-Track Control

POWER-UP INTO A PREBIASED OUTPUT — START-UP USING INHIBIT CONTROL

The capability to start up into an output prebias condition is now available to all the 12-V input, PTH series of power modules. (Note that this is a feature enhancement for the many of the W-suffix products) ^[1].

A prebias startup condition occurs as a result of an external voltage being present at the output of a power module prior to its output becoming active. This often occurs in complex digital systems when current from another power source is backfed through a dual-supply logic component, such as an FPGA or ASIC. Another path might be via clamp diodes, sometimes used as part of a dual-supply power-up sequencing arrangement. A prebias can cause problems with power modules that incorporate synchronous rectifiers. This is because under most operating conditions, such modules can sink as well as source output current. The 12-V input PTH modules all incorporate synchronous rectifiers, but does not sink current during startup, or whenever the Inhibit pin is held low.

Conditions for Prebias Holdoff

In order for the module to allow an output prebias voltage to exist (and not sink current), certain conditions must be maintained. The module holds off a prebias voltage when the Inhibit pin is held low, and whenever the output is allowed to rise under soft-start control. Power up under soft-start control occurs upon the removal of the ground signal to the Inhibit pin (with input voltage applied), or when input power is applied with Auto-Track disabled ^[2]. To further ensure that the regulator doesn't sink output current, (even with a ground signal applied to its Inhibit), the input voltage must always be greater than the applied prebias source. This condition must exist throughout the power-up sequence ^[3].

The soft-start period is complete when the output begins rising above the prebias voltage. Once it is complete the module functions as normal, and sinks current if a voltage higher than the nominal regulation value is applied to its output.

Note: If a prebias condition is not present, the soft-start period is complete when the output voltage has risen to either the set-point voltage, or the voltage applied at the module's Track control pin, whichever is lowest. to its output.

Prebias Demonstration Circuit

Figure 17 shows the startup waveforms for the demonstration circuit shown in Figure 18. The initial rise in V_{O2} is the prebias voltage, which is passed from the VCCIO to the V_{CORE} voltage rail through the ASIC. Note that the output current from the PTH12010L module (I_{O2}) is negligible until its output voltage rises above the applied prebias.

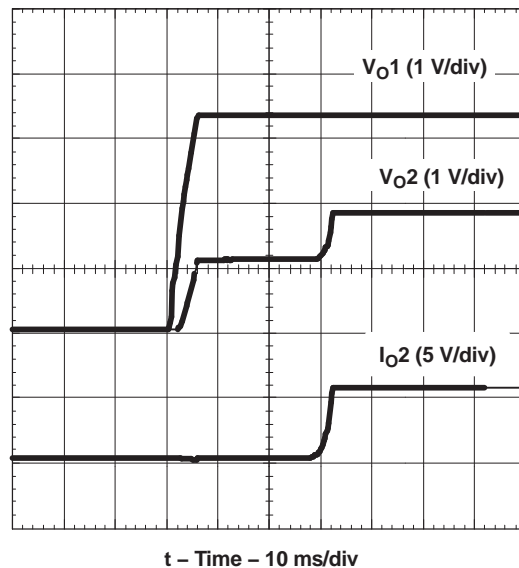

Figure 17. Prebias Startup Waveforms

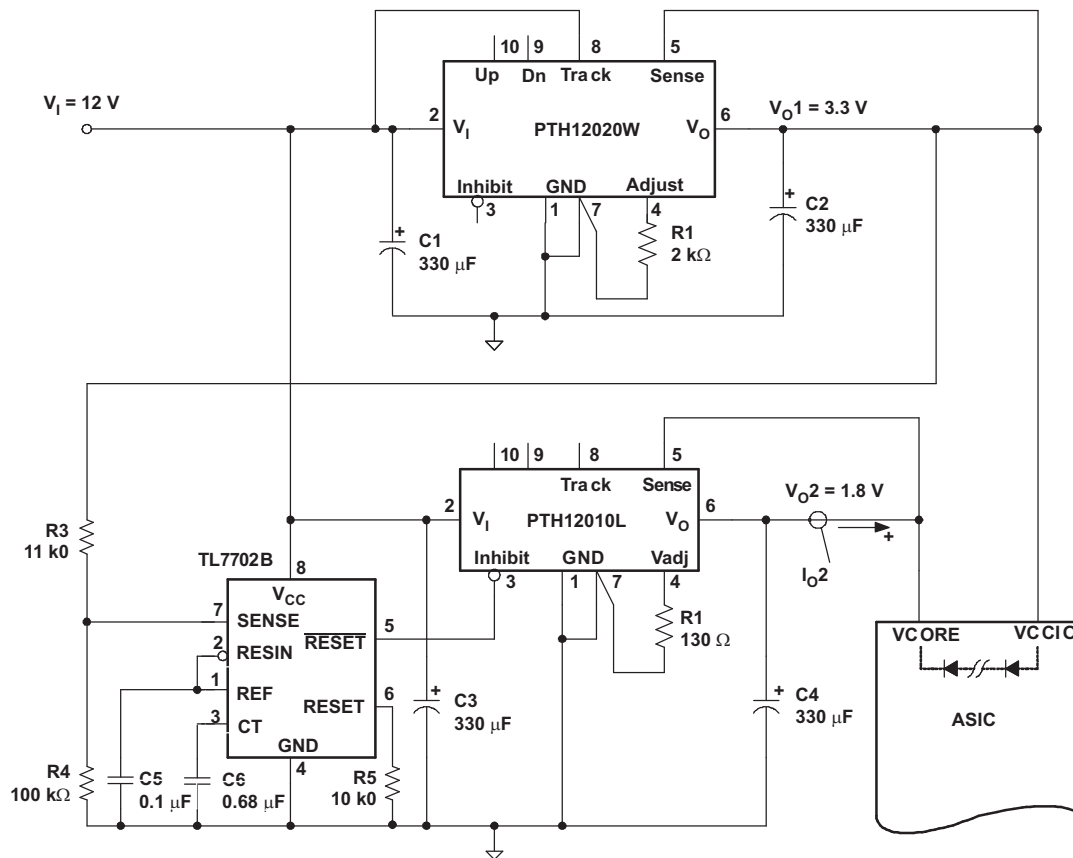

Figure 18. Application Circuit Demonstrating Prebias Startup

Notes:

1. Output prebias holdoff is an inherent feature to all PTH120x0L and PTV120x0W/L modules. It has now been incorporated into all modules (including W-suffix modules with part numbers of the form PTH120x0W), with a production lot date code of 0423 or later.
2. The prebias start-up feature is not compatible with Auto-Track. If the rise in the output is limited by the voltage applied to the Track control pin, the output sinks current during the period that the track control voltage is below that of the back-feeding source. For this reason, it is recommended that Auto-Track be disabled when not being used. This is accomplished by connecting the Track pin to the input voltage, V_I . This raises the Track pin voltage well above the set-point voltage prior to the module's start up, thereby, defeating the Auto-Track feature.
3. To further ensure that the regulator's output does not sink current when power is first applied (even with a ground signal applied to the Inhibit control pin), the input voltage must always be greater than the applied prebias source. This condition must exist *throughout* the power-up sequence of the power system.

Overcurrent Protection

For protection against load faults, all modules incorporate output overcurrent protection. Applying a load that exceeds the regulator's overcurrent threshold causes the regulated output to shut down. Following shutdown, a module periodically attempts to recover by initiating a soft-start power-up. This is described as a *hiccup* mode of operation, whereby, the module continues in a cycle of successive shutdown and power up until the load fault is removed. During this period, the average current flowing into the fault is significantly reduced. Once the fault is removed, the module automatically recovers and returns to normal operation.

Overtemperature Protection (OTP)

The PTH12020, PTV12020, and PTH12030 products have overtemperature protection. These products have an on-board temperature sensor that protects the module's internal circuitry against excessively high temperatures. A rise in the internal temperature may be the result of a drop in airflow, or a high ambient temperature. If the internal temperature exceeds the OTP threshold, the module's Inhibit control is internally pulled low. This turns the output off. The output voltage drops as the external output capacitors are discharged by the load circuit. The recovery is automatic, and begins with a soft-start power up. It occurs when the sensed temperature decreases by about 10°C below the trip point.

Note: The overtemperature protection is a last resort mechanism to prevent thermal stress to the regulator. Operation at or close to the thermal shutdown temperature is not recommended and will reduce the long-term reliability of the module. Always operate the regulator within the specified Safe Operating Area (SOA) limits for the worst-case conditions of ambient temperature and airflow.

PACKAGING INFORMATION

Orderable Device	Status ⁽¹⁾	Package Type	Package Drawing	Pins	Package Qty	Eco Plan ⁽²⁾	Lead/ Ball Finish	MSL Peak Temp ⁽³⁾	Samples (Requires Login)
PTV12010LAD	ACTIVE	SIP MODULE	EVA	8	70	Pb-Free (RoHS)	SN	N / A for Pkg Type	Request Free Samples
PTV12010LAH	ACTIVE	SIP MODULE	EVA	8	70	Pb-Free (RoHS)	SN	N / A for Pkg Type	Request Free Samples
PTV12010WAD	ACTIVE	SIP MODULE	EVA	8	70	Pb-Free (RoHS)	SN	N / A for Pkg Type	Purchase Samples
PTV12010WAH	ACTIVE	SIP MODULE	EVA	8	70	Pb-Free (RoHS)	SN	N / A for Pkg Type	Request Free Samples

⁽¹⁾ The marketing status values are defined as follows:

ACTIVE: Product device recommended for new designs.

LIFEBUY: TI has announced that the device will be discontinued, and a lifetime-buy period is in effect.

NRND: Not recommended for new designs. Device is in production to support existing customers, but TI does not recommend using this part in a new design.

PREVIEW: Device has been announced but is not in production. Samples may or may not be available.

OBSOLETE: TI has discontinued the production of the device.

⁽²⁾ Eco Plan - The planned eco-friendly classification: Pb-Free (RoHS), Pb-Free (RoHS Exempt), or Green (RoHS & no Sb/Br) - please check <http://www.ti.com/productcontent> for the latest availability information and additional product content details.

TBD: The Pb-Free/Green conversion plan has not been defined.

Pb-Free (RoHS): TI's terms "Lead-Free" or "Pb-Free" mean semiconductor products that are compatible with the current RoHS requirements for all 6 substances, including the requirement that lead not exceed 0.1% by weight in homogeneous materials. Where designed to be soldered at high temperatures, TI Pb-Free products are suitable for use in specified lead-free processes.

Pb-Free (RoHS Exempt): This component has a RoHS exemption for either 1) lead-based flip-chip solder bumps used between the die and package, or 2) lead-based die adhesive used between the die and leadframe. The component is otherwise considered Pb-Free (RoHS compatible) as defined above.

Green (RoHS & no Sb/Br): TI defines "Green" to mean Pb-Free (RoHS compatible), and free of Bromine (Br) and Antimony (Sb) based flame retardants (Br or Sb do not exceed 0.1% by weight in homogeneous material)

⁽³⁾ MSL, Peak Temp. -- The Moisture Sensitivity Level rating according to the JEDEC industry standard classifications, and peak solder temperature.

Important Information and Disclaimer: The information provided on this page represents TI's knowledge and belief as of the date that it is provided. TI bases its knowledge and belief on information provided by third parties, and makes no representation or warranty as to the accuracy of such information. Efforts are underway to better integrate information from third parties. TI has taken and continues to take reasonable steps to provide representative and accurate information but may not have conducted destructive testing or chemical analysis on incoming materials and chemicals. TI and TI suppliers consider certain information to be proprietary, and thus CAS numbers and other limited information may not be available for release.

In no event shall TI's liability arising out of such information exceed the total purchase price of the TI part(s) at issue in this document sold by TI to Customer on an annual basis.

EVA (R-PDSS-T8)

DOUBLE SIDED MODULE

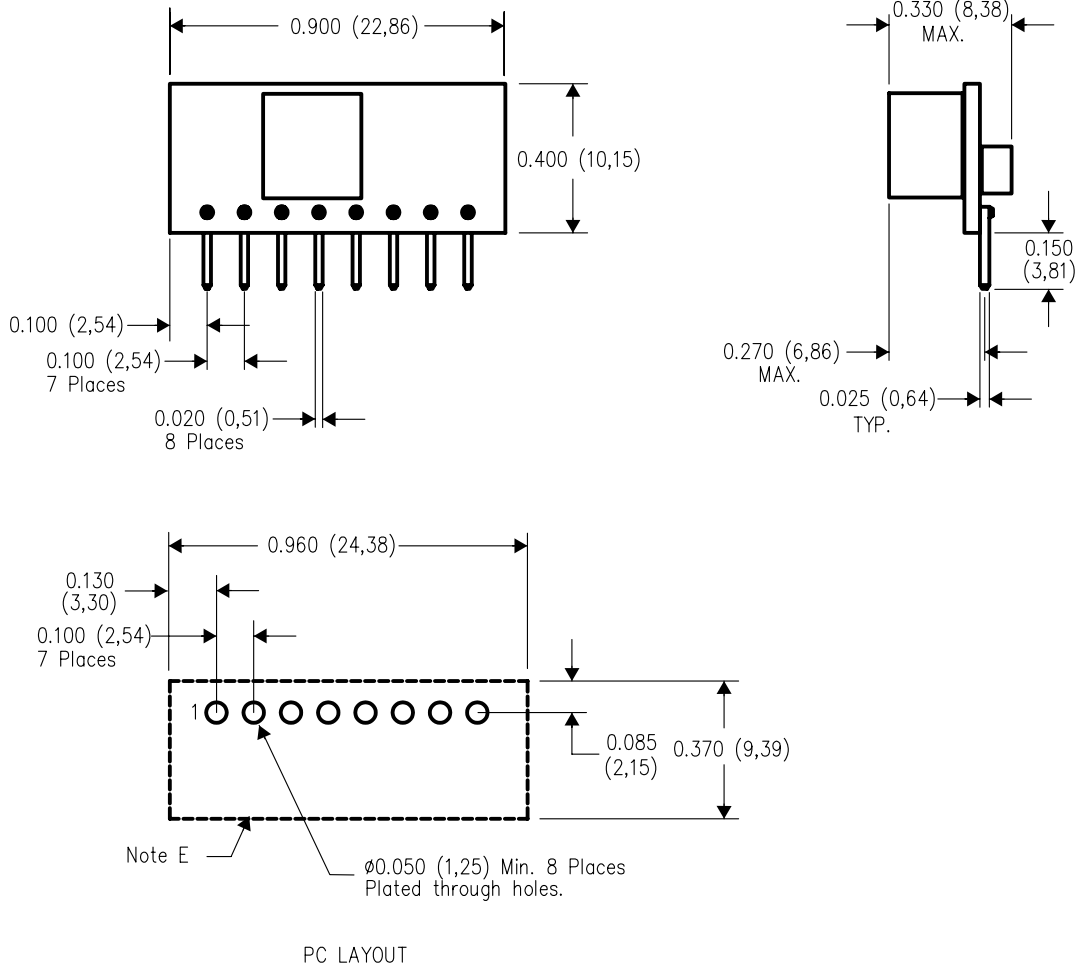

4205909/A 03/04

- NOTES:
- A. All linear dimensions are in inches (mm).
 - B. This drawing is subject to change without notice.
 - C. 2 place decimals are ± 0.030 ($\pm 0,76$ mm).
 - D. 3 place decimals are ± 0.010 ($\pm 0,25$ mm).
 - E. Recommended keep out area for user components.
 - F. Pins are 0.020" (0,51) x 0.025" (0,64).
 - G. All pins: Material - Copper Alloy
Finish - Tin (100%) over Nickel plate

IMPORTANT NOTICE

Texas Instruments Incorporated and its subsidiaries (TI) reserve the right to make corrections, modifications, enhancements, improvements, and other changes to its products and services at any time and to discontinue any product or service without notice. Customers should obtain the latest relevant information before placing orders and should verify that such information is current and complete. All products are sold subject to TI's terms and conditions of sale supplied at the time of order acknowledgment.

TI warrants performance of its hardware products to the specifications applicable at the time of sale in accordance with TI's standard warranty. Testing and other quality control techniques are used to the extent TI deems necessary to support this warranty. Except where mandated by government requirements, testing of all parameters of each product is not necessarily performed.

TI assumes no liability for applications assistance or customer product design. Customers are responsible for their products and applications using TI components. To minimize the risks associated with customer products and applications, customers should provide adequate design and operating safeguards.

TI does not warrant or represent that any license, either express or implied, is granted under any TI patent right, copyright, mask work right, or other TI intellectual property right relating to any combination, machine, or process in which TI products or services are used. Information published by TI regarding third-party products or services does not constitute a license from TI to use such products or services or a warranty or endorsement thereof. Use of such information may require a license from a third party under the patents or other intellectual property of the third party, or a license from TI under the patents or other intellectual property of TI.

Reproduction of TI information in TI data books or data sheets is permissible only if reproduction is without alteration and is accompanied by all associated warranties, conditions, limitations, and notices. Reproduction of this information with alteration is an unfair and deceptive business practice. TI is not responsible or liable for such altered documentation. Information of third parties may be subject to additional restrictions.

Resale of TI products or services with statements different from or beyond the parameters stated by TI for that product or service voids all express and any implied warranties for the associated TI product or service and is an unfair and deceptive business practice. TI is not responsible or liable for any such statements.

TI products are not authorized for use in safety-critical applications (such as life support) where a failure of the TI product would reasonably be expected to cause severe personal injury or death, unless officers of the parties have executed an agreement specifically governing such use. Buyers represent that they have all necessary expertise in the safety and regulatory ramifications of their applications, and acknowledge and agree that they are solely responsible for all legal, regulatory and safety-related requirements concerning their products and any use of TI products in such safety-critical applications, notwithstanding any applications-related information or support that may be provided by TI. Further, Buyers must fully indemnify TI and its representatives against any damages arising out of the use of TI products in such safety-critical applications.

TI products are neither designed nor intended for use in military/aerospace applications or environments unless the TI products are specifically designated by TI as military-grade or "enhanced plastic." Only products designated by TI as military-grade meet military specifications. Buyers acknowledge and agree that any such use of TI products which TI has not designated as military-grade is solely at the Buyer's risk, and that they are solely responsible for compliance with all legal and regulatory requirements in connection with such use.

TI products are neither designed nor intended for use in automotive applications or environments unless the specific TI products are designated by TI as compliant with ISO/TS 16949 requirements. Buyers acknowledge and agree that, if they use any non-designated products in automotive applications, TI will not be responsible for any failure to meet such requirements.

Following are URLs where you can obtain information on other Texas Instruments products and application solutions:

Products

Audio	www.ti.com/audio
Amplifiers	amplifier.ti.com
Data Converters	dataconverter.ti.com
DLP® Products	www.dlp.com
DSP	dsp.ti.com
Clocks and Timers	www.ti.com/clocks
Interface	interface.ti.com
Logic	logic.ti.com
Power Mgmt	power.ti.com
Microcontrollers	microcontroller.ti.com
RFID	www.ti-rfid.com
RF/IF and ZigBee® Solutions	www.ti.com/lprf

Applications

Communications and Telecom	www.ti.com/communications
Computers and Peripherals	www.ti.com/computers
Consumer Electronics	www.ti.com/consumer-apps
Energy and Lighting	www.ti.com/energy
Industrial	www.ti.com/industrial
Medical	www.ti.com/medical
Security	www.ti.com/security
Space, Avionics and Defense	www.ti.com/space-avionics-defense
Transportation and Automotive	www.ti.com/automotive
Video and Imaging	www.ti.com/video
Wireless	www.ti.com/wireless-apps

TI E2E Community Home Page

e2e.ti.com

Mailing Address: Texas Instruments, Post Office Box 655303, Dallas, Texas 75265
Copyright © 2011, Texas Instruments Incorporated