

阅读申明

- 1.本站收集的数据手册和产品资料都来自互联网，版权归原作者所有。如读者和版权方有任何异议请及时告之，我们将妥善解决。
- 2.本站提供的中文数据手册是英文数据手册的中文翻译，其目的是协助用户阅读，该译文无法自动跟随原稿更新，同时也可能存在翻译上的不当。建议读者以英文原稿为参考以便获得更精准的信息。
- 3.本站提供的产品资料，来自厂商的技术支持或者使用者的心得体会等，其内容可能存在描述上的差异，建议读者做出适当判断。
- 4.如需与我们联系，请发邮件到marketing@iczoom.com，主题请标有“数据手册”字样。

Read Statement

1. The datasheets and other product information on the site are all from network reference or other public materials, and the copyright belongs to the original author and original published source. If readers and copyright owners have any objections, please contact us and we will deal with it in a timely manner.
2. The Chinese datasheets provided on the website is a Chinese translation of the English datasheets. Its purpose is for reader's learning exchange only and do not involve commercial purposes. The translation cannot be automatically updated with the original manuscript, and there may also be improper translations. Readers are advised to use the English manuscript as a reference for more accurate information.
3. All product information provided on the website refer to solutions from manufacturers' technical support or users the contents may have differences in description, and readers are advised to take the original article as the standard.
4. If you have any questions, please contact us at marketing@iczoom.com and mark the subject with "Datasheets" .

FEATURES

- Extremely Low Supply Current(50µA,Typ.)
- Very Low Dropout Voltage
- 300mA Output Current
- High Output Voltage Accuracy +/- 1.4 %
- Standard or Custom Output Voltages
- Over Current and Over Temperature Protection
- Small input/output differential : 0.3V for full load

APPLICATIONS

- Battery Operated Systems
- Portable Computers
- Portable Cameras and Video Recorders
- Medical Instruments
- Instrumentation
- Cellular/GSM/PHS Phones
- Linear Post-Regulators for SMPS
- Pagers

DESCRIPTION

The LM1108 is a fixed output, high accuracy (typically $\pm 0.5\%$) C MOS low drop-out regulator. Total supply current is typically 50µA at full load (20 to 60 times lower than in bipolar regulators). LM1108 key features include ultra low noise operation, very low dropout voltage (typically 240mV at full load), and fast response to step changes in load. The LM1108 incorporates both over temperature and over current protection. The LM1108 is stable with an output capacitor of only 1µF and has a maximum output current of 300mA. It is available in a SOT-23 & SOT-89 package

TYPICAL APPLICATION CIRCUIT

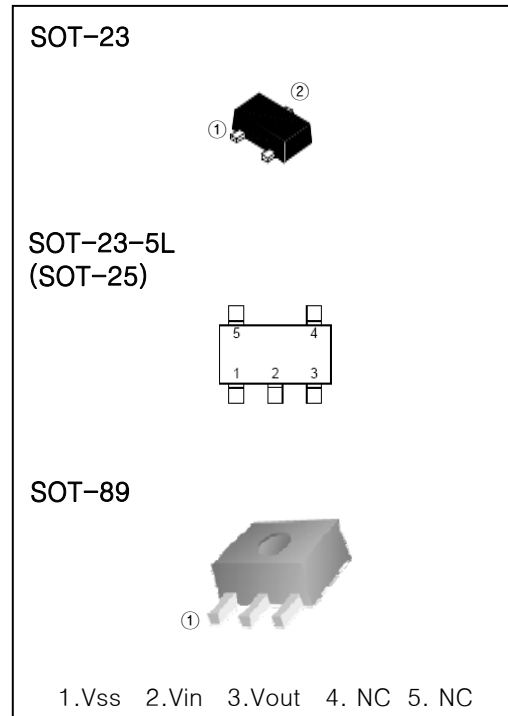
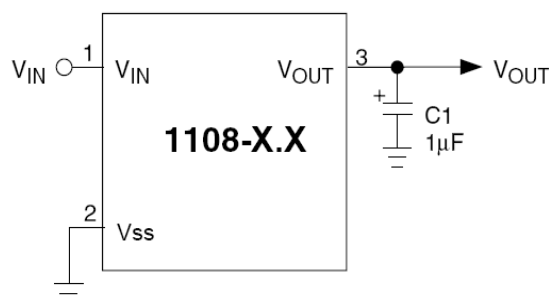

ORDERING INFORMATION

Device	Marking	Package
LM1108 SF	HXX	SOT-23
LM1108 SF5	HXX	SOT-25
LM1108 F	1108 X.X	SOT-89

(Note : "XX" is Output Voltage for SOT-23 Pkg, 1.5V=H15, 1.8V=H18....3.3V=H33)

ABSOLUTE MAXIMUM RATING (Note 1)

Supply Voltage (Vin)	+6.5V
Output Current (Iout)	300 mA
Output Voltage (Vout)	Vss-0.3 to Vin+0.3V
Total Power Dissipation (Pd) SOT-89	500 mW
SOT-23	230 mW
Operating Ambient Temperature (Topr)	-30 ~ +80 °C
Lead Temperature (soldering, 5 sec)	260°C
Storage Temperature (Tstg)	-40 ~ +125 °C

ELECTRICAL CHARACTERISTICS

Parameter	Symbol	Condition	Limit			Units
			Min	Typ	Max	
Output Voltage Accuracy	Vout	Io=1mA				V
		Io=0~300 mA				
Line Regulation	$\Delta V_{out}/\Delta V_{in}$	Io=1mA,				%/V
Load Regulation(Note.1)	$\Delta V_{out}/\Delta I_o$	Vin=6V, 0.1mA<Io<300 mA,		0.005	0.04	%/mA
Maximum Output Current	Io	Vin=5V, Vout >0.96VRATING	300	500		mA
Current Limit			400			mA
Ground Current	Ignd	Io=0~300 mA		15	30	μA
Dropout Voltage for Vout>2.5V 2.0V<Vout<2.5V Vout<2.0V	Vdrop	Io=100 mA		100	180	mV
		Io=300 mA		300	550	
		Io=100 mA		150	300	
		Io=300 mA		450	800	
		Io=100 mA		200	400	
		Io=300 mA		600	1100	

Note.1 : Load Regulation is measured using pulse techniques with duty cycle<5%

Detail Description

- The LM1108 is a precision, fixed output LDO.

Unlike bipolar regulators, the LM1108's supply current does not increase with load current. In addition, V_{OUT} remains stable and within regulation over the entire 0mA to I_{OUT} MAX operating load current range, (an important consideration in RTC and CMOS RAM battery back-up applications). Figure 3-1 shows a typical application circuit.

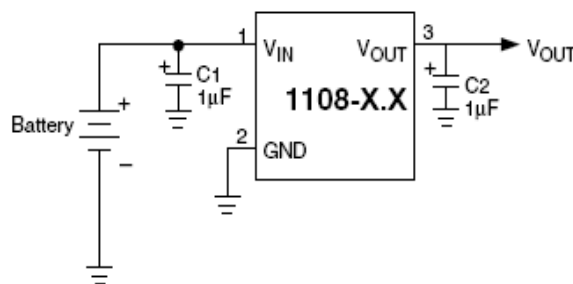

1. Output Capacitor

1µF(min) capacitor from V_{OUT} to ground is required. The output capacitor should have an effective series resistance greater than 0.1 Ω and less than 0.0Ω. 1µF capacitor should be connected from VIN to GND if there is more than 10 inches of wire between the regulator and the AC filter capacitor, or if a battery is used as the power source. Aluminum electrolytic or tantalum capacitor types can be used. (Since many aluminum electrolytic capacitors freeze at approximately -30°C, solid tantalums are recommended for applications operating below -25°C.) When operating from sources other than batteries, supply-noise rejection and transient response can be improved by increasing the value of the input and output capacitors and employing passive filtering techniques.

2. THERMAL CONSIDERATIONS

2.1 Thermal Shutdown

Integrated thermal protection circuitry shuts the regulator off when die temperature exceeds 150°C. The regulator remains off until the die temperature drops to approximately 140°C.

2.2 Power Dissipation

The amount of power the regulator dissipates is primarily a function of input and output voltage, and output current. The following equation is used to calculate worst case actual power dissipation:

EQUATION 2-1:

The maximum allowable power dissipation (Equation 2-2) is a function of the maximum ambient temperature (T_{AMAX}), the maximum allowable die temperature (T_{JMAX}) and the thermal resistance from junction-to-air (θ_{JA}).

TABLE 2-1 :

$P_D \approx (V_{INMAX} - V_{OUTMIN}) I_{LOADMAX}$ <p>Where:</p> <ul style="list-style-type: none"> P_D = Worst case actual power dissipation V_{INMAX} = Maximum voltage on V_{IN} V_{OUTMIN} = Minimum regulator output voltage I_{LOADMAX} = Maximum output (load) current

EQUATION 2-2:

$$P_{D\text{MAX}} = \frac{(T_{J\text{MAX}} - T_{A\text{MAX}})}{\theta_{JA}}$$

Where all terms are previously defined.

Table 2-1 shows various values of θ_{JA} for the LM1108 versus board copper area.

TABLE 2-1 : THERMAL RESISTANCE GUIDELINES FOR LM1108

Copper Area (Topside)*	Copper Area (Backside)	Board Area	Thermal Resistance (θ_{JA})
2500 sq mm	2500 sq mm	2500 sq mm	45°C/W
1000 sq mm	2500 sq mm	2500 sq mm	45°C/W
225 sq mm	2500 sq mm	2500 sq mm	53°C/W
100 sq mm	2500 sq mm	2500 sq mm	59°C/W
1000 sq mm	1000 sq mm	1000 sq mm	52°C/W
1000 sq mm	0 sq mm	1000 sq mm	55°C/W

NOTE: *Tab of device attached to topside copper

Equation 2-1 can be used in conjunction with Equation 2-2 to ensure regulator thermal operation is within limits. Forexample:

Given:

$$\begin{aligned} V_{IN\text{MAX}} &= 3.3V + 10\% \\ V_{OUT\text{MIN}} &= 2.7V - 0.5\% \\ I_{LOAD\text{MAX}} &= 275\text{mA} \\ T_{J\text{MAX}} &= 125^\circ\text{C} \\ T_{A\text{MAX}} &= 95^\circ\text{C} \\ \theta_{JA} &= 59^\circ\text{C/W} \end{aligned}$$

Find: 1. Actual power dissipation
2. Maximum allowable dissipation

Actual power dissipation:

$$\begin{aligned} P_D &\approx (V_{IN\text{MAX}} - V_{OUT\text{MIN}})I_{LOAD\text{MAX}} \\ &= [(3.3 \times 1.1) - (2.7 \times .995)]275 \times 10^{-3} \\ &= 260\text{mW} \end{aligned}$$

Maximum allowable power dissipation:

$$\begin{aligned} P_{D\text{MAX}} &= \frac{(T_{J\text{MAX}} - T_{A\text{MAX}})}{\theta_{JA}} \\ &= \frac{(125 - 95)}{59} \\ &= 508\text{mW} \end{aligned}$$

In this example, the LM1108 dissipates a maximum of 260mW; below the allow able limit of 508 mW . In a similar manner, Equation 2-1 and Equation 2-2 can be used to calculate maximum current and/or input voltage limits. For example, the maximum allowable V_{IN} , is found by substituting the maximum allowable power dissipation of 508 mW into Equation 2-1, from which $V_{IN\text{MAX}} = 4.6V$.