

阅读申明

- 1.本站收集的数据手册和产品资料都来自互联网，版权归原作者所有。如读者和版权方有任何异议请及时告之，我们将妥善解决。
- 2.本站提供的中文数据手册是英文数据手册的中文翻译，其目的是协助用户阅读，该译文无法自动跟随原稿更新，同时也可能存在翻译上的不当。建议读者以英文原稿为参考以便获得更精准的信息。
- 3.本站提供的产品资料，来自厂商的技术支持或者使用者的心得体会等，其内容可能存在描述上的差异，建议读者做出适当判断。
- 4.如需与我们联系，请发邮件到marketing@iczoom.com，主题请标有“数据手册”字样。

Read Statement

1. The datasheets and other product information on the site are all from network reference or other public materials, and the copyright belongs to the original author and original published source. If readers and copyright owners have any objections, please contact us and we will deal with it in a timely manner.
2. The Chinese datasheets provided on the website is a Chinese translation of the English datasheets. Its purpose is for reader's learning exchange only and do not involve commercial purposes. The translation cannot be automatically updated with the original manuscript, and there may also be improper translations. Readers are advised to use the English manuscript as a reference for more accurate information.
3. All product information provided on the website refer to solutions from manufacturers' technical support or users the contents may have differences in description, and readers are advised to take the original article as the standard.
4. If you have any questions, please contact us at marketing@iczoom.com and mark the subject with "Datasheets" .



Chilisin Electronics Singapore Pte Ltd

High Current Chip Beads, PBX Series

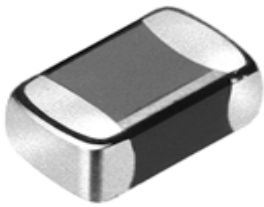

Feature:

Our SMD High Current Chips Beads is specially designed to with Stand large Currents while providing a means of EMI/RFI attenuation for electronics products. Its has a full range different sizes to choose from.

Ordering Code:

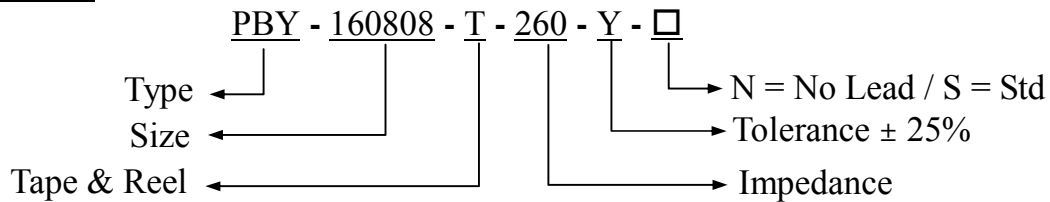

Dimension in mm:

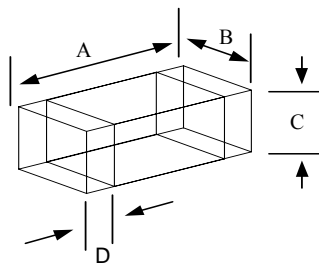

Type	A	B	C	D
PBX - 100505	1.0 ± 0.1	0.5 ± 0.1	0.5 ± 0.1	0.25 ± 0.1
PBX - 160808	1.6 ± 0.2	0.8 ± 0.15	0.8 ± 0.15	0.4 ± 0.2
PBX - 201209	2.0 ± 0.2	1.25 ± 0.2	0.9 ± 0.2	0.5 ± 0.3
PBX - 321611	3.2 ± 0.2	1.6 ± 0.2	0.6 ± 0.2	0.5 ± 0.3
PBX - 322513	3.2 ± 0.2	2.5 ± 0.2	1.3 ± 0.2	0.5 ± 0.3
PBX - 451616	4.5 ± 0.25	1.6 ± 0.2	1.6 ± 0.2	0.5 ± 0.3
PBX - 453215	4.5 ± 0.25	3.2 ± 0.2	1.5 ± 0.2	0.5 ± 0.3

Electrical:

Part Number	Impedance	Current
PBX-100505- Series	10Ω	1000mA
PBX-160808 - Series	11 Ω to 1000 Ω	4000 mA to 800 mA
PBX-201209 - Series	11 Ω to 1500 Ω	6000 mA to 1500 mA
PBX-321611 - Series	19 Ω to 1500 Ω	6000 mA to 800 mA
PBX-322513 - Series	60 Ω TO 90 Ω	4000mA to 3000mA
PBX-451616 - Series	50 Ω to 150 Ω	6000 Ma to 2000 mA
PBX-453215 - Series	70 Ω to 600 Ω	6000 mA to 2000 mA



Chilisin Electronics Singapore Pte Ltd

High Current Chip Beads, PBY Series



Electrical Characteristics:

Part Number	Impedance (ohm)	Test Frequency (MHz)	DC Resistance (ohms) Max	Rated Current (mA) Max
PBY-100505-T-100Y-□	10 ± 25%	100	0.030Ω	1000
PBY-160808-T-110Y-□	11 ± 25%	100	0.020 Ω	4000
PBY-160808-T-250Y-□	25 ± 25%	100	0.030 Ω	3000
PBY-160808-T-400Y-□	40 ± 25%	100	0.035Ω	3000
PBY-160808-T-600Y-□	60 ± 25%	100	0.04 Ω	3000
PBY-160808-T-121Y-□	120 ± 25%	100	0.08 Ω	2500
PBY-160808-T-151Y-□	150 ± 25%	100	0.085 Ω	2000
PBY-160808-T-181Y-□	180 ± 25%	100	0.09 Ω	2000
PBY-160808-T-201Y-□	200 ± 25%	100	0.095 Ω	2000
PBY-160808-T-301Y-□	300 ± 25%	100	0.10 Ω	2000
PBY-160808-T-500Y-□	500 ± 25%	100	0.15 Ω	1500
PBY-160808-T-601Y-□	600 ± 25%	100	0.20 Ω	1000
PBY-160808-T-102Y-□	1000 ± 25%	100	0.25Ω	800
PBY-201209-T-110Y-□	11 ± 25%	100	0.010Ω	6000
PBY-201209-T-170Y-□	17 ± 25%	100	0.02 Ω	5000
PBY-201209-T-300Y-□	30 ± 25%	100	0.015Ω	5000
PBY-201209-T-500Y-□	50 ± 25%	100	0.025Ω	3000
PBY-201209-T-600Y-□	60 ± 25%	100	0.03Ω	3000
PBY-201209-T-800Y-□	80 ± 25%	100	0.040Ω	3000
PBY-201209-T-121Y-□	120 ± 25%	100	0.040Ω	3000
PBY-201209-T-201Y-□	200 ± 25%	100	0.050Ω	2500
PBY-201209-T-301Y-□	300 ± 25%	100	0.08Ω	2000
PBY-201209-T-601Y-□	600 ± 25%	100	0.100Ω	2000
PBY-201209-T-102Y-□	1000 ± 25%	100	0.12Ω	1500



Chilisin Electronics Singapore Pte Ltd

High Current Chip Beads, PBY Series



Electrical Characteristics:

Part Number	Impedance (ohm)	Test Frequency (MHz)	DC Resistance (ohms) Max	Rated Current (mA) Max
PBY-321611-T-190Y-□	19 ± 25%	100	0.015Ω	6000
PBY-321611-T-320Y-□	32 ± 25%	100	0.015Ω	4000
PBY-321611-T-500Y-□	50 ± 25%	100	0.020Ω	4000
PBY-321611-T-700Y-□	70 ± 25%	100	0.020Ω	4000
PBY-321611-T-800Y-□	80 ± 25%	100	0.025Ω	4000
PBY-321611-T-900Y-□	90 ± 25%	100	0.030Ω	4000
PBY-321611-T-121Y-□	120 ± 25%	100	0.020Ω	3000
PBY-321611-T-601Y-□	600 ± 25%	100	0.100Ω	2000
PBY-321611-T-102Y-□	1000 ± 25%	50	0.15Ω	1200
PBY-321611-T-122Y-□	1200 ± 25%	50	0.18Ω	1000
PBY-321611-T-152Y-□	1500 ± 25%	50	0.20Ω	800
PBY-322513-T-600Y-□	60 ± 25%	100	0.25Ω	4000
PBY-322513-T-900Y-□	90 ± 25%	100	0.25Ω	3000
PBY-451616-T-500Y-□	50 ± 25%	100	0.020Ω	6000
PBY-451616-T-600Y-□	60 ± 25%	100	0.020Ω	5000
PBY-451616-T-800Y-□	80 ± 25%	100	0.025Ω	4000
PBY-451616-T-900Y-□	90 ± 25%	100	0.040Ω	4000
PBY-451616-T-151Y-□	150 ± 25%	100	0.100Ω	2000
PBY-453215-T-700Y-□	70 ± 25%	100	0.030Ω	6000
PBY-453215-T-121Y-□	120 ± 25%	100	0.030Ω	4000
PBY-453212-T-151Y-□	150 ± 25%	100	0.030Ω	4000
PBY-453215-T-601Y-□	600 ± 25%	100	0.100Ω	2000



Chilisin Electronics Singapore Pte Ltd

High Current Chip Beads, PBY Series



Tape Dimensions:

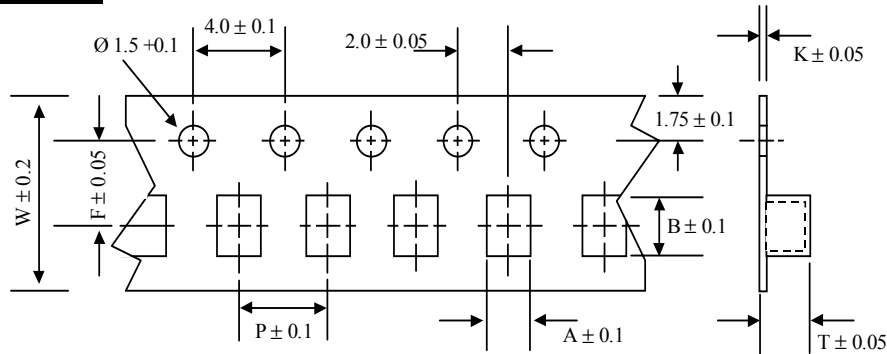

Type	A	B	T	W	P	F	K
PBY-100505	0.65	1.15	-	8.0	2.0	3.5	0.6
PBY-160808	1.10	1.85	-	8.0	4.0	3.5	0.95
PBY-201209	1.42	2.25	1.04	8.0	4.0	3.5	0.22
PBY-321611	1.88	3.50	1.27	8.0	4.0	3.5	0.22
PBY-322513	2.77	3.42	1.55	8.0	4.0	.35	0.22
PBY-451616	1.93	4.95	1.93	12.0	4.0	5.5	0.24
PBY-453215	3.66	4.95	1.85	12.0	8.0	5.5	0.24

Tape Material:

Carrier Tape: Polystyrene
Cover Type : Polyethylene

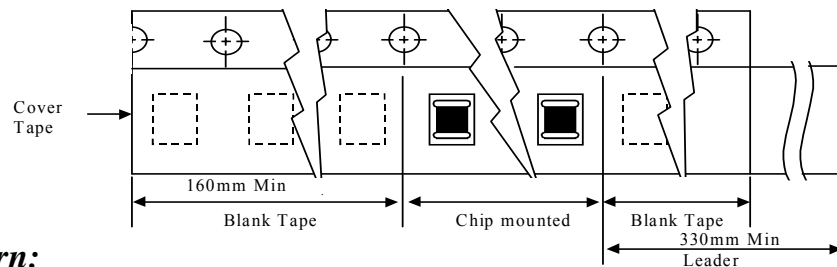

Recommended Pattern:

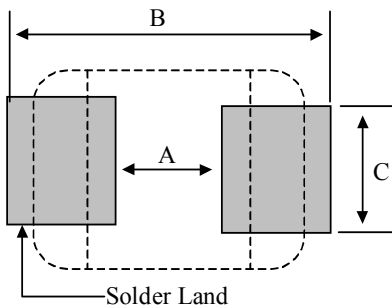

Type	A	B	C
PBY-100505	0.4 ~ 0.6	1.6 ~ 2.6	0.4 ~ 0.7
PBY-160808	0.8	2.4 ~ 3.4	0.6
PBY-201209	1.2	3.0 ~ 4.0	1.0
PBY-321611	2.0	4.2 ~ 5.2	1.2
PBY-322522	2.0	5.5 ~ 6.5	1.8
PBY-451616	3.0	5.5 ~ 6.5	1.2
PBY-453215	3.0	5.5 ~ 6.5	2.4

19, Woodlands Industrial Park E1 #03-07 Singapore 757719
Tel : 65 - 68921191 Fax : 65 - 67606760



Chilisin Electronics Singapore Pte Ltd

High Current Chip Beads, PBY Series



Reel Dimensions:

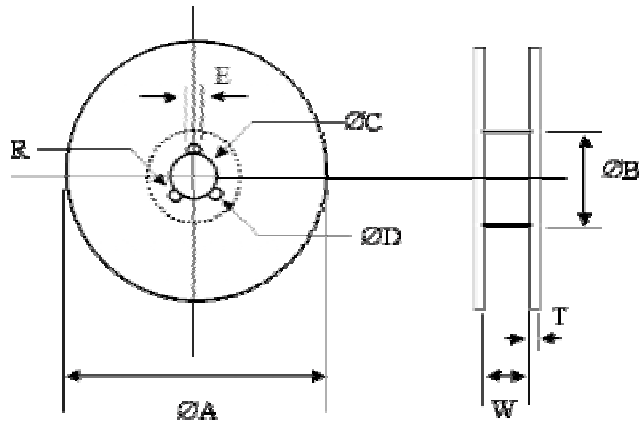

ØA	ØB	ØC	ØD	E	W	T	R
178 ±2	60 ±1	13.0 ±0.5	21.0 ±0.8	2.0 ±0.5	10.0 ±1.0	2.0 ±0.5	1.0

Tape peeling:

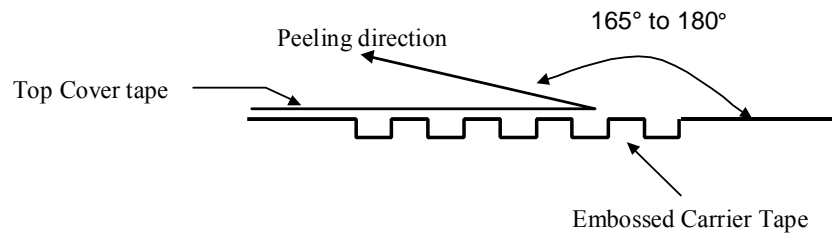

Recommended Soldering profile:

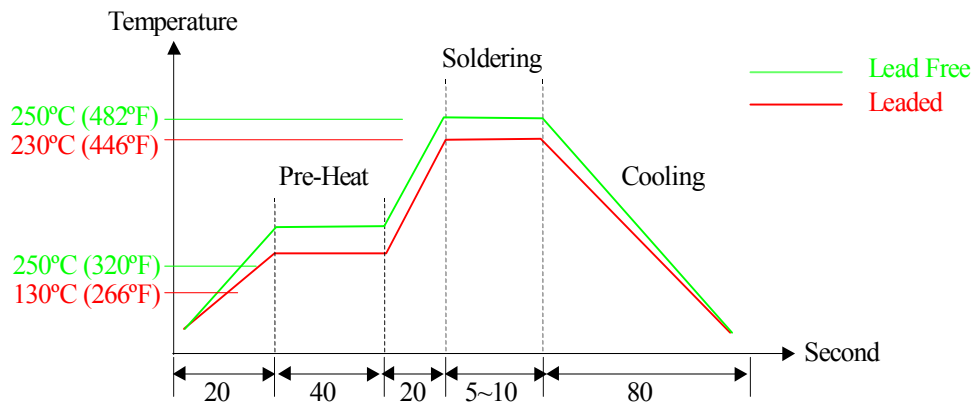

19, Woodlands Industrial Park E1 #03-07 Singapore 757719
Tel : 65 - 68921191 Fax : 65 - 67606760



Chilisin Electronics Singapore Pte Ltd

High Current Chip Beads, PBY Series



General Component Specification for Chips Beads

Reliability Test (Mechanical Performance)

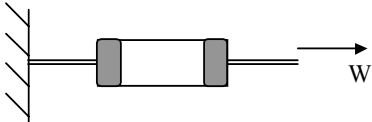
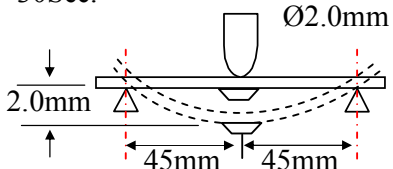
No.	Item	Specification	Test Condition
1.	Solderability	More than 90% of the terminal Electrode shall be covered with fresh solder	Pre heat = 150°C Pre heat Time = 1 minute Solder = Sn/Ag3.0/Cu0.5 (Pb –Free) Solder Temperature = 245°C ± 5°C Immersion Time = 4 ± 1 Sec
2.	Resistance to Soldering Heat	The chips shall not crack. More than 75% of the terminal Electrode Shall be cover with solder	Pre Heat = 150°C Pre heat Time = 1 minute Solder = Sn/Ag3.0/Cu0.5 (Pb –Free) Solder Temperature = 260°C ± 5°C Immersion Time = 10 ± 1 Sec
3.	Terminal Strength Test	1005 Series = 0.2 kg (30 Sec) 1608 Series = 0.5 kg (30 Sec) 2012 Series = 1.0 kg (30 Sec) Others Series = 2.0 kg (30 Sec) BAY/BAQ = 1.5 kg (30 Sec)	Test device should be solder on Substrate 
4.	Bending Strength	The Ferrite and Terminal Electrode shall not be damage When force are applied per test Condition on the right	Test device shall be solder to substrate Substrate Dimension = 100mmx40mmx1.6mm Deflection = 2.0mm Duration = 30Sec.  For 1005 Substrate size 100mmx40mmx0.8mm
4.	Vibration		Test Device shall be soldered on the substrate Oscillation Freq.= 10 to 55 to 10Hz for 1 min Amplitude = 1.5mm Time = 2hrs for each axis (X,Y&Z) total 6 hrs

19, Woodlands Industrial Park E1 #03-07 Singapore 757719

Tel : 65 - 68921191 Fax : 65 - 67606760



Chilisin Electronics Singapore Pte Ltd

High Current Chip Beads, PBY Series



Reliability Test (Environmental Performance)

No.	Item	Specification	Test Condition															
5.	Temperature Cycle	Appearance No damage Impedance within $\pm 20\%$ Of the initial value	One Cycle <table border="1" style="margin-left: 20px;"> <thead> <tr> <th>Step</th> <th>Temperate</th> <th>Time (min)</th> </tr> </thead> <tbody> <tr> <td>1</td> <td>-55°C</td> <td>30</td> </tr> <tr> <td>2</td> <td>25°C</td> <td>3</td> </tr> <tr> <td>3</td> <td>125°C</td> <td>30</td> </tr> <tr> <td>4</td> <td>25°C</td> <td>3</td> </tr> </tbody> </table> Total 100 Cycles Measured after exposure in room condition = 24hrs	Step	Temperate	Time (min)	1	-55°C	30	2	25°C	3	3	125°C	30	4	25°C	3
Step	Temperate	Time (min)																
1	-55°C	30																
2	25°C	3																
3	125°C	30																
4	25°C	3																
6	Humidity Resistance		Temperature: $+40^{\circ}\text{C} \pm 2^{\circ}\text{C}$ Humidity: 90% to 95% Time 1000 ± 12 Hours Measured after exposure in room condition = 24hrs															
7	High Temperature Resistance		Temperature = $125^{\circ}\text{C} \pm 3^{\circ}\text{C}$ Relative Humidity = 0% Applied Current = Rated Current as state Time = $1000 \text{ hrs} \pm 12 \text{ hrs}$ Measure after exposure in room Condition = 24hrs															
8.	Low Temperature Resistance		Temperature = $-55^{\circ}\text{C} \pm 3^{\circ}\text{C}$ Relative Humidity = 0% Time = $1000 \text{ hrs} \pm 12 \text{ hrs}$ Measure after exposure in room Condition = 24hrs															