

阅读申明

- 1.本站收集的数据手册和产品资料都来自互联网，版权归原作者所有。如读者和版权方有任何异议请及时告之，我们将妥善解决。
- 2.本站提供的中文数据手册是英文数据手册的中文翻译，其目的是协助用户阅读，该译文无法自动跟随原稿更新，同时也可能存在翻译上的不当。建议读者以英文原稿为参考以便获得更精准的信息。
- 3.本站提供的产品资料，来自厂商的技术支持或者使用者的心得体会等，其内容可能存在描述上的差异，建议读者做出适当判断。
- 4.如需与我们联系，请发邮件到marketing@iczoom.com，主题请标有“数据手册”字样。

Read Statement

1. The datasheets and other product information on the site are all from network reference or other public materials, and the copyright belongs to the original author and original published source. If readers and copyright owners have any objections, please contact us and we will deal with it in a timely manner.
2. The Chinese datasheets provided on the website is a Chinese translation of the English datasheets. Its purpose is for reader's learning exchange only and do not involve commercial purposes. The translation cannot be automatically updated with the original manuscript, and there may also be improper translations. Readers are advised to use the English manuscript as a reference for more accurate information.
3. All product information provided on the website refer to solutions from manufacturers' technical support or users the contents may have differences in description, and readers are advised to take the original article as the standard.
4. If you have any questions, please contact us at marketing@iczoom.com and mark the subject with "Datasheets" .

QXK

Metallized Polyester Film Capacitor

(Extended Standard Type)



- Highly reliable and superior performance in high frequency applications, self-healing and non-inductive construction, using a dielectric made of polyethylene terephthalate film covered with vacuum-evaporated metal.
- Large capacitance in small dimensions.
- Finished by inner dipping with liquid epoxy resin and outer coating with flame-retardant epoxy resin, those double coating provides excellent humidity resistance.
- Designed 1mm max. of epoxy on lead wire for best performance at soldering process on P.C. board assemblies.
- Compliant to the RoHS directive (2011/65/EU).

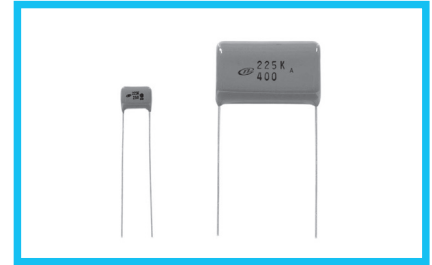

Applications

- General electronic and communications equipment. Contact us for details for use in AC circuits.
- However, do not use this product for across-the-line applications.

Specifications

Item	Performance Characteristics
Category Temperature Range	-40 to +105°C (Rated temperature : 85°C)
Rated Voltage (U _R)	250, 400, 630VDC
Rated Capacitance Range	0.01 to 10μF
Capacitance Tolerance	±5% (J)※, ±10% (K)
Dielectric Loss Tangent	0.8% or less (at 1kHz 20°C)
Insulation Resistance	C ≤ 0.33μF : 9000 MΩ or more C > 0.33μF : 3000 ΩF or more
Withstand Voltage	Between Terminals : Rated Voltage × 175%, 1 to 5 secs. Between Terminals and Coverage : Rated Voltage × 200%, 1 to 5 secs.
Encapsulation	Flame retardant epoxy resin

※ Except for 250VDC 0.01 to 0.15μF
400VDC 0.01 to 0.033μF

Category voltage = U_R × 0.7

Type numbering system (Example : 630V 0.01μF)

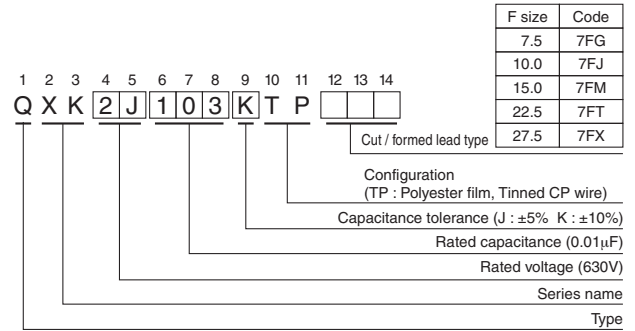

AC Voltage

- AC Voltage (Operating at 50 / 60Hz AC circuit) shall be as follows. However, do not use this product for across-the-line applications.

DC Rated Voltage	250VDC	400VDC	630VDC
AC Voltage	125VAC	200VAC	250VAC

※ When operating capacitors in the high frequency circuit, maximum permissible value (VAC) can be calculated from table 2, provided that the effective current (I_e) and the effective VA (V_e × V_e) shall not exceed the values specified in table 4. Shown in Pages 379, 382.

Drawing

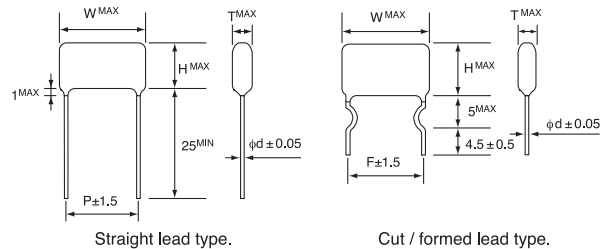

Dimensions

Cap.(μF)	V(Code) Code	Size	250VDC (2E)						400VDC (2G)						630VDC (2J)					
			T	W	H	d	P	F	T	W	H	d	P	F	T	W	H	d	P	F
0.01	103		4.4	11.0	8.1	0.6	7.5	7.5	4.4	11.0	8.1	0.6	7.5	7.5	4.4	13.5	9.5	0.6	10.0	10.0
0.015	153		5.0	11.0	8.7	0.6	7.5	7.5	5.0	11.0	8.7	0.6	7.5	7.5	4.7	13.5	9.8	0.6	10.0	10.0
0.022	223		4.4	11.0	8.5	0.6	7.5	7.5	4.3	11.0	8.4	0.6	7.5	7.5	5.1	13.5	10.8	0.6	10.0	10.0
0.033	333		4.4	11.0	8.5	0.6	7.5	7.5	4.9	11.0	9.1	0.6	7.5	7.5	5.9	13.5	11.6	0.6	10.0	10.0
0.047	473		4.0	11.0	8.1	0.6	7.5	7.5	4.7	13.5	9.8	0.6	10.0	10.0	6.4	13.5	13.7	0.6	10.0	10.0
0.068	683		4.7	11.0	8.7	0.6	7.5	7.5	5.4	13.5	10.5	0.6	10.0	10.0	5.8	18.5	11.5	0.6	15.0	15.0
0.1	104		5.2	11.0	9.4	0.6	7.5	7.5	6.1	13.5	11.7	0.6	10.0	10.0	6.4	18.5	13.7	0.6	15.0	15.0
0.15	154		6.1	11.0	10.3	0.6	7.5	7.5	5.1	18.5	12.4	0.6	15.0	15.0	7.1	18.5	15.9	0.6	15.0	15.0
0.22	224		5.9	13.5	11.0	0.6	10.0	10.0	5.9	18.5	13.2	0.6	15.0	15.0	9.6	18.5	15.3	0.6	15.0	15.0
0.33	334		6.7	13.5	12.4	0.6	10.0	10.0	7.6	18.5	13.3	0.6	15.0	15.0	7.9	25.5	16.7	0.8	22.5	22.5
0.47	474		5.5	18.5	12.8	0.6	15.0	15.0	8.3	18.5	15.6	0.6	15.0	15.0	9.4	25.5	18.2	0.8	22.5	22.5
0.68	684		6.0	18.5	14.8	0.6	15.0	15.0	7.2	25.5	16.1	0.8	22.5	22.5	11.3	25.5	20.1	0.8	22.5	22.5
1.0	105		7.1	18.5	16.0	0.6	15.0	15.0	8.7	25.5	17.6	0.8	22.5	22.5	12.0	30.5	21.0	0.8	27.5	27.5
1.5	155		9.9	18.5	15.6	0.6	15.0	15.0	9.4	30.5	18.5	0.8	27.5	27.5	14.8	30.5	23.8	0.8	27.5	27.5
2.2	225		8.1	25.5	17.0	0.8	22.5	22.5	11.5	30.5	20.5	0.8	27.5	27.5	18.5	30.5	28.0	0.8	27.5	27.5
3.3	335		10.0	25.5	18.8	0.8	22.5	22.5												
4.7	475		12.0	25.5	20.8	0.8	22.5	22.5												
6.8	685		12.7	30.5	21.8	0.8	27.5	27.5												
10.0	106		15.6	30.5	24.7	0.8	27.5	27.5												

F : lead pitch for cut / formed lead wires

Please contact us and let us know the specification you need.