

阅读申明

- 1.本站收集的数据手册和产品资料都来自互联网，版权归原作者所有。如读者和版权方有任何异议请及时告之，我们将妥善解决。
- 2.本站提供的中文数据手册是英文数据手册的中文翻译，其目的是协助用户阅读，该译文无法自动跟随原稿更新，同时也可能存在翻译上的不当。建议读者以英文原稿为参考以便获得更精准的信息。
- 3.本站提供的产品资料，来自厂商的技术支持或者使用者的心得体会等，其内容可能存在描述上的差异，建议读者做出适当判断。
- 4.如需与我们联系，请发邮件到marketing@iczoom.com，主题请标有“数据手册”字样。

Read Statement

1. The datasheets and other product information on the site are all from network reference or other public materials, and the copyright belongs to the original author and original published source. If readers and copyright owners have any objections, please contact us and we will deal with it in a timely manner.
2. The Chinese datasheets provided on the website is a Chinese translation of the English datasheets. Its purpose is for reader's learning exchange only and do not involve commercial purposes. The translation cannot be automatically updated with the original manuscript, and there may also be improper translations. Readers are advised to use the English manuscript as a reference for more accurate information.
3. All product information provided on the website refer to solutions from manufacturers' technical support or users the contents may have differences in description, and readers are advised to take the original article as the standard.
4. If you have any questions, please contact us at marketing@iczoom.com and mark the subject with "Datasheets" .

4

3

2

1

THIS DRAWING IS UNPUBLISHED. RELEASED FOR PUBLICATION 1825059, 1825059
 © COPYRIGHT 1825059 - ALL RIGHTS RESERVED.

REVISIONS					
P	LTR	DESCRIPTION	DATE	DWN	APVD
	A5	REVISED PER ECO-15-015220	27OCT2015	NK	RH
	A6	REVISED PER ECO-16-018654	15MAY2017	RK	PO

SPECIFICATIONS:

MATERIAL

BASE, PPS, UL94V-0, BLACK
 COVER, PPS, UL94V-0, BLACK
 ACTUATOR, PA6T, UL94V-0, WHITE
 FIXED CONTACT/TERMINAL, CU ALLOY-GOLD FLASH OVER NICKEL
 MOVING CONTACT, CU ALLOY, PLATE-GOLD FLASH/NICKEL
 TAPE SEAL-POLYIMIDE FILM, AMBER, SEE P/N TABLE FOR OPTIONS

ELECTRICAL

MAX CONTACT RATING SWITCHING, 100MILLIAMP @ 24 VDC
 MIN CONTACT RATING SWITCHING, .1MICROAMP @ 1 MILLIVOLT
 MAX CONTACT NON-SWITCHING, 1AMP @ 5 VDC
 INITIAL CONTACT RESISTANCE, 50 MILLIOHMS MAX.
 CONTACT RESISTANCE (AFTER ENVIRONMENTAL TEST), 100 MILLIOHMS
 CONTACT RESISTANCE (AFTER GAS TEST), 300 MILLIOHMS
 INSULATION RESISTANCE, 1,000 MEGOHMS MIN. @ 100 VDC
 DIELECTRIC STRENGTH, 500 VAC RMS @ SEA LEVEL
 LIFE EXPECTANCY, 1,000 CYCLES

MECHANICAL

OPERATING FORCE, LESS THAN 800 GRAMS
 CONTACT PRESSURE, 280,000 PSI

ENVIRONMENTAL

OPERATING TEMPERATURE, -30 TO +85 DEGREES C
 STORAGE TEMPERATURE, -45 TO +105 DEGREES C
 CLEANING, AQUEOUS OR SOLVENT
 SOLDER HEAT RESISTANCE, PER 109-201, COND B, SWITCH "OFF".
 SOLDERABILITY PER JIS C 0050 & JIS C 0053.

Technical drawing of a 4-pin DIP switch. The top view shows four pins labeled 1, 2, 3, and 4. Dimensions include: overall length DIM L ± 0.5 [0.020], pin pitch 2.54 [.100] TYP, and a 1.30 [.051] STROKE. A detail view shows a 1.40 [.055] TYP dimension. A note 'DATE CODE' points to a location on the switch. A triangle symbol with the number 4 indicates a terminal option. A side view shows a height of 7.5 [.295].

- SWITCHES TO BE RECEIVED IN THE "OFF" POSITION AND PACKAGED IN CLEAR TUBES TO ACCOMMODATE AUTO-INSERTION OR PACKAGED ON TAPE AND REEL
- TOP SURFACE TO BE CLEARLY MARKED AS SHOWN
- SWITCHES TO BE BLACK WITH WHITE ACTUATORS AND MARKINGS.
- TERMINAL OPTION: OLD T&B P/N ADExxS, SA OR SB
 S= OUTSIDE "L" TERMINALS; SA= INSIDE "L" TERMINALS;
 SB= BUTT TERMINALS
- ALL MATERIALS AND FINISHES SHALL COMPLY WITH EU DIRECTIVE 2002/95/EC OF 27JAN2003 (ROHS)
- TOP TAPE SEAL AVAILABLE, SEE TABLE FOR OPTIONS.
- TAPE AND REEL PACKAGING PER EIA 481.
- OBsolete PARTS: OBSOLETE CIS STREAMLINING PER D.RENAUD/D.SINISI

SEE SHEET 3 FOR PART NUMBER TABLE
 SEE SHEET 2 FOR MOUNTING OPTIONS

THIS DRAWING IS A CONTROLLED DOCUMENT.		DWN B.S.VISWESWARA 11FEB05	TE Connectivity																				
DIMENSIONS: mm [INCHES]		CHK M.SARVER				NAME																	
TOLERANCES UNLESS OTHERWISE SPECIFIED:		APVD M.SARVER	PRODUCT SPEC																				
<table border="1"> <tr><td>0 PLC</td><td>±</td><td>-</td></tr> <tr><td>1 PLC</td><td>±</td><td>-</td></tr> <tr><td>2 PLC</td><td>±</td><td>0.30[012]</td></tr> <tr><td>3 PLC</td><td>±</td><td>-</td></tr> <tr><td>4 PLC</td><td>±</td><td>-</td></tr> <tr><td>ANGLES</td><td>±</td><td>-</td></tr> </table>		0 PLC	±	-	1 PLC	±	-	2 PLC	±	0.30[012]	3 PLC	±	-	4 PLC	±	-	ANGLES	±	-	APPLICATION SPEC			RESTRICTED TO
0 PLC	±	-																					
1 PLC	±	-																					
2 PLC	±	0.30[012]																					
3 PLC	±	-																					
4 PLC	±	-																					
ANGLES	±	-																					
MATERIAL		WEIGHT	SIZE A2	CAGE CODE -	DRAWING NO. C-1825059																		
FINISH		CUSTOMER DRAWING		SCALE 4:1	SHEET 1 OF 3																		
				REV A6																			

1471-9 (1/15)

REVISIONS					
P	LTR	DESCRIPTION	DATE	DWN	APVD
-	-	SEE SHEET 1	-	-	-

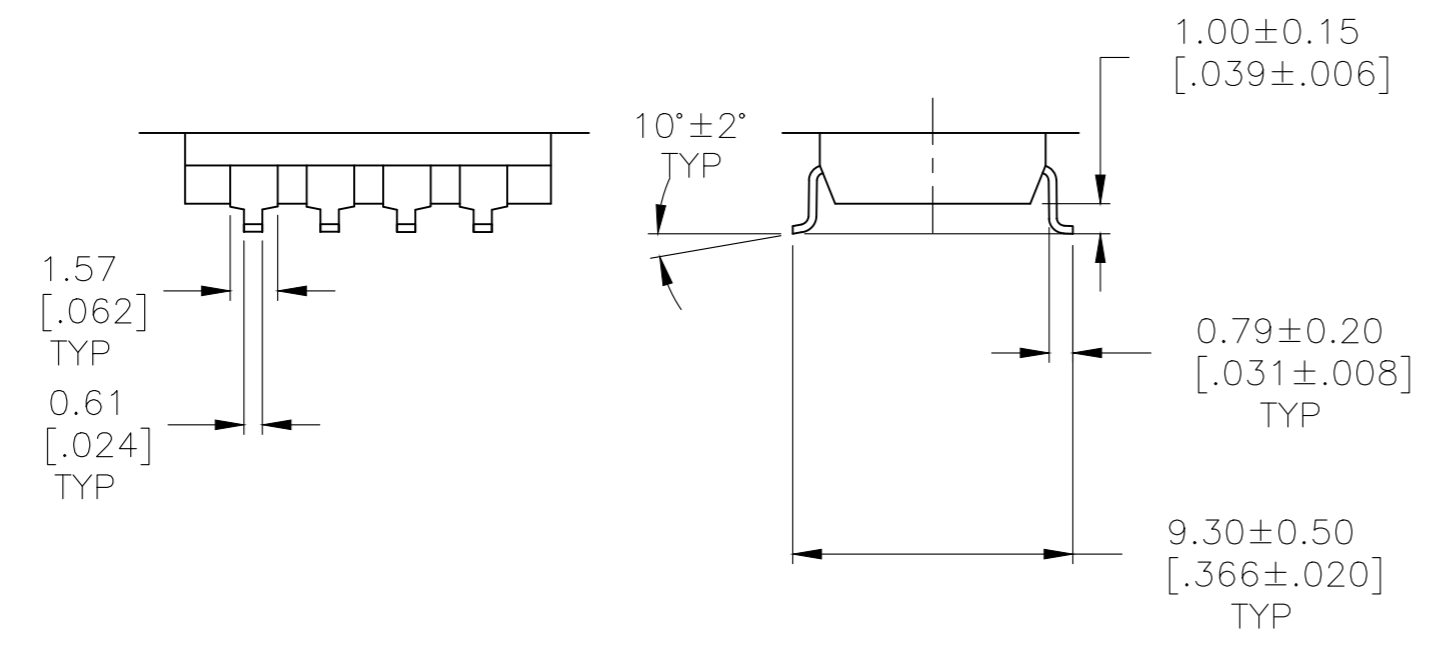

SURFACE MOUNT
S (OUTSIDE "L")

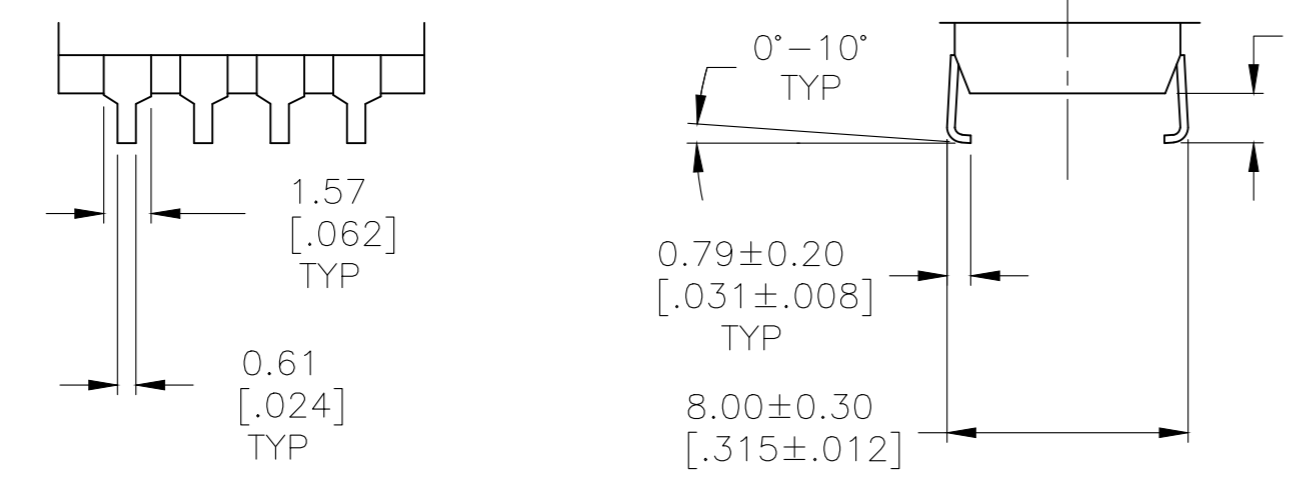

SURFACE MOUNT
SA (INSIDE "L")

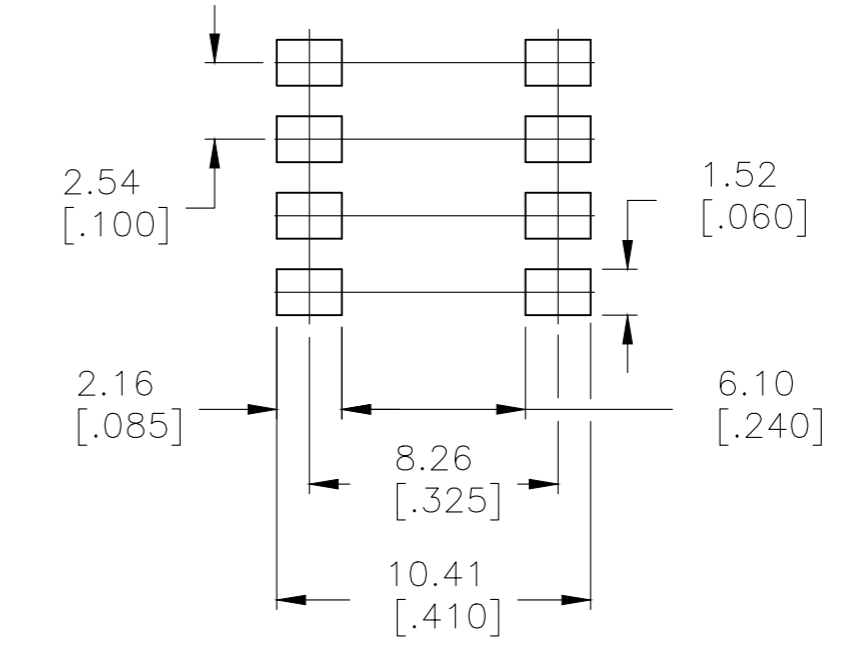

RECOMMENDED PAD LAYOUT

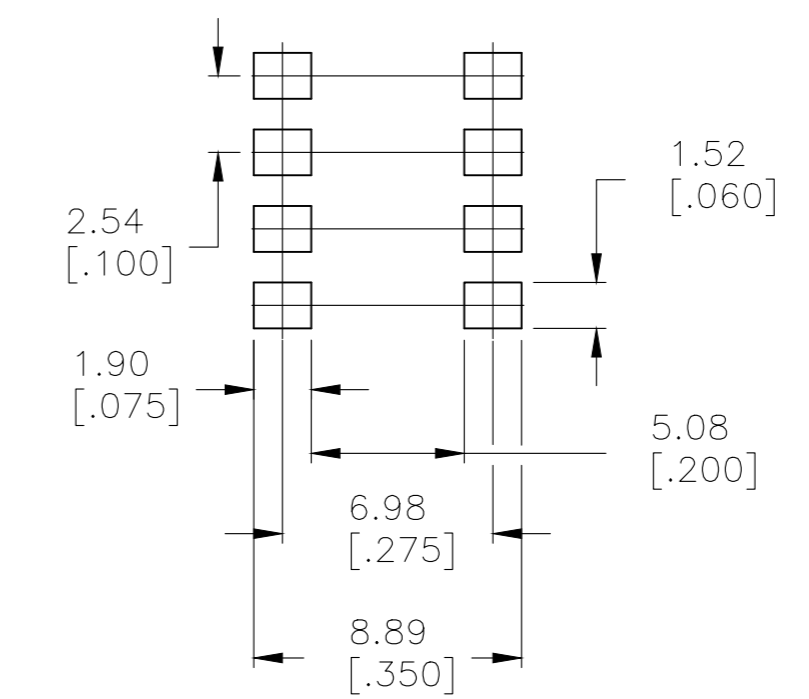

RECOMMENDED PAD LAYOUT

THIS DRAWING IS A CONTROLLED DOCUMENT.		DWN B.S.VISWESWARA 11FEB05	TE Connectivity		
DIMENSIONS: mm [INCHES]		CHK M.SARVER			
TOLERANCES UNLESS OTHERWISE SPECIFIED:		APVD M.SARVER	PRODUCT SPEC		
0 PLC ± - 1 PLC ± - 2 PLC ± 0.30[.012] 3 PLC ± - 4 PLC ± - ANGLES ± -		APPLICATION SPEC		RESTRICTED TO	
MATERIAL		WEIGHT	SIZE A2	CAGE CODE	DRAWING NO. 1825059
FINISH		CUSTOMER DRAWING		SCALE 4:1	SHEET 2 OF 3
				REV A6	

THIS DRAWING IS UNPUBLISHED. 1825059, 1825059
 RELEASED FOR PUBLICATION ALL RIGHTS RESERVED.

REVISIONS					
P	LTR	DESCRIPTION	DATE	DWN	APVD
-	-	SEE SHEET 1	-	-	-

	ADF10STR04	3.50[.138]	27.36[1.078]	NO	10	6-1825059-2
	ADF03STR04	3.50[.138]	9.60[.378]	NO	3	6-1825059-1
OBSOLETE	ADF12STTR04	3.61[.142]	32.51[1.280]	YES	12	6-1825059-0
OBSOLETE	ADF12ST04	3.61[.142]	32.51[1.280]	YES	12	5-1825059-9
OBSOLETE	ADF12SATTR04	3.61[.142]	32.51[1.280]	YES	12	5-1825059-8
OBSOLETE	ADF12SAT04	3.61[.142]	32.51[1.280]	YES	12	5-1825059-7
OBSOLETE	ADF12SA04	3.61[.142]	32.51[1.280]	NO	12	5-1825059-6
OBSOLETE	ADF12S04	3.61[.142]	32.51[1.280]	NO	12	5-1825059-5
	ADF10STTR04	3.50[.138]	27.36[1.078]	YES	10	5-1825059-4
	ADF10ST04	3.50[.138]	27.36[1.078]	YES	10	5-1825059-3
OBSOLETE	ADF10SATTR04	3.50[.138]	27.36[1.078]	YES	10	5-1825059-2
OBSOLETE	ADF10SAT04	3.50[.138]	27.36[1.078]	YES	10	5-1825059-1
OBSOLETE	ADF10SA04	3.50[.138]	27.36[1.078]	NO	10	5-1825059-0
	ADF10S04	3.50[.138]	27.36[1.078]	NO	10	4-1825059-9
	ADF09STTR04	3.50[.138]	24.54[.978]	YES	9	4-1825059-8
OBSOLETE	ADF09ST04	3.50[.138]	24.54[.978]	YES	9	4-1825059-7
OBSOLETE	ADF09SATTR04	3.50[.138]	24.54[.978]	YES	9	4-1825059-6
OBSOLETE	ADF09SAT04	3.50[.138]	24.54[.978]	YES	9	4-1825059-5
OBSOLETE	ADF09SA04	3.50[.138]	24.54[.978]	NO	9	4-1825059-4
	T&B P/N	DIM H	DIM L	SEAL	POS	PART NO.

OBSOLETE	ADF09S04	3.50[.138]	24.54[.978]	NO	9	4-1825059-3
	ADF08STTR04	3.50[.138]	22.30[.878]	YES	8	4-1825059-2
	ADF08ST04	3.50[.138]	22.30[.878]	YES	8	4-1825059-1
	ADF08SATTR04	3.50[.138]	22.30[.878]	YES	8	4-1825059-0
OBSOLETE	ADF08SAT04	3.50[.138]	22.30[.878]	YES	8	3-1825059-9
	ADF08SA04	3.50[.138]	22.30[.878]	NO	8	3-1825059-8
	ADF08S04	3.50[.138]	22.30[.878]	NO	8	3-1825059-7
	ADF07STTR04	3.50[.138]	19.76[.778]	YES	7	3-1825059-6
	ADF07ST04	3.50[.138]	19.76[.778]	YES	7	3-1825059-5
OBSOLETE	ADF07SATTR04	3.50[.138]	19.76[.778]	YES	7	3-1825059-4
OBSOLETE	ADF07SAT04	3.50[.138]	19.76[.778]	YES	7	3-1825059-3
OBSOLETE	ADF07SA04	3.50[.138]	19.76[.778]	NO	7	3-1825059-2
	ADF07S04	3.50[.138]	19.76[.778]	NO	7	3-1825059-1
	ADF06STTR04	3.50[.138]	17.22[.678]	YES	6	3-1825059-0
	ADF06ST04	3.50[.138]	17.22[.678]	YES	6	2-1825059-9
OBSOLETE	ADF06SATTR04	3.50[.138]	17.22[.678]	YES	6	2-1825059-8
OBSOLETE	ADF06SAT04	3.50[.138]	17.22[.678]	YES	6	2-1825059-7
OBSOLETE	ADF06SA04	3.50[.138]	17.22[.678]	NO	6	2-1825059-6
	ADF06S04	3.50[.138]	17.22[.678]	NO	6	2-1825059-5
	ADF05STTR04	3.50[.138]	14.68[.578]	YES	5	2-1825059-4
	ADF05ST04	3.50[.138]	14.68[.578]	YES	5	2-1825059-3
OBSOLETE	ADF05SATTR04	3.50[.138]	14.68[.578]	YES	5	2-1825059-2
OBSOLETE	ADF05SAT04	3.50[.138]	14.68[.578]	YES	5	2-1825059-1
OBSOLETE	ADF05SA04	3.50[.138]	14.68[.578]	NO	5	2-1825059-0
	ADF05S04	3.50[.138]	14.68[.578]	NO	5	1-1825059-9
	ADF04STTR04	3.50[.138]	12.14[.478]	YES	4	1-1825059-8
	ADF04ST04	3.50[.138]	12.14[.478]	YES	4	1-1825059-7
	ADF04SATTR04	3.50[.138]	12.14[.478]	YES	4	1-1825059-6
	ADF04SAT04	3.50[.138]	12.14[.478]	YES	4	1-1825059-5
	ADF04SA04	3.50[.138]	12.14[.478]	NO	4	1-1825059-4
	ADF04S04	3.50[.138]	12.14[.478]	NO	4	1-1825059-3
	ADF03STTR04	3.50[.138]	9.60[.378]	YES	3	1-1825059-2
	ADF03ST04	3.50[.138]	9.60[.378]	YES	3	1-1825059-1
OBSOLETE	ADF03SATTR04	3.50[.138]	9.60[.378]	YES	3	1-1825059-0
OBSOLETE	ADF03SAT04	3.50[.138]	9.60[.378]	YES	3	1-1825059-9
	ADF03SA04	3.50[.138]	9.60[.378]	NO	3	1-1825059-8
	ADF03S04	3.50[.138]	9.60[.378]	NO	3	1-1825059-7
	ADF02STTR04	3.50[.138]	7.06[.278]	YES	2	1-1825059-6
	ADF02ST04	3.50[.138]	7.06[.278]	YES	2	1-1825059-5
OBSOLETE	ADF02SATTR04	3.50[.138]	7.06[.278]	YES	2	1-1825059-4
	ADF02SAT04	3.50[.138]	7.06[.278]	YES	2	1-1825059-3
OBSOLETE	ADF02SA04	3.50[.138]	7.06[.278]	NO	2	1-1825059-2
	ADF02S04	3.50[.138]	7.06[.278]	NO	2	1-1825059-1
	T&B P/N	DIM H	DIM L	SEAL	POS	PART NO.

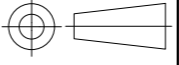
THIS DRAWING IS A CONTROLLED DOCUMENT.		DWN B.S.VISWESWARA	11FEB05	 TE Connectivity	
DIMENSIONS: mm [INCHES]		CHK M.SARVER	APVD M.SARVER		
		TOLERANCES UNLESS OTHERWISE SPECIFIED: 0 PLC ± - 1 PLC ± - 2 PLC ± 0.30[.012] 3 PLC ± - 4 PLC ± - ANGLES ± -		PRODUCT SPEC APPLICATION SPEC	
MATERIAL		FINISH		SIZE A2	CAGE CODE -
				DRAWING NO. C-1825059	RESTRICTED TO -
				WEIGHT -	SCALE 4:1
				CUSTOMER DRAWING	SHEET 3 OF 3
				REV A6	