

阅读申明

- 1.本站收集的数据手册和产品资料都来自互联网，版权归原作者所有。如读者和版权方有任何异议请及时告之，我们将妥善解决。
- 2.本站提供的中文数据手册是英文数据手册的中文翻译，其目的是协助用户阅读，该译文无法自动跟随原稿更新，同时也可能存在翻译上的不当。建议读者以英文原稿为参考以便获得更精准的信息。
- 3.本站提供的产品资料，来自厂商的技术支持或者使用者的心得体会等，其内容可能存在描述上的差异，建议读者做出适当判断。
- 4.如需与我们联系，请发邮件到marketing@iczoom.com，主题请标有“数据手册”字样。

Read Statement

1. The datasheets and other product information on the site are all from network reference or other public materials, and the copyright belongs to the original author and original published source. If readers and copyright owners have any objections, please contact us and we will deal with it in a timely manner.
2. The Chinese datasheets provided on the website is a Chinese translation of the English datasheets. Its purpose is for reader's learning exchange only and do not involve commercial purposes. The translation cannot be automatically updated with the original manuscript, and there may also be improper translations. Readers are advised to use the English manuscript as a reference for more accurate information.
3. All product information provided on the website refer to solutions from manufacturers' technical support or users the contents may have differences in description, and readers are advised to take the original article as the standard.
4. If you have any questions, please contact us at marketing@iczoom.com and mark the subject with "Datasheets" .

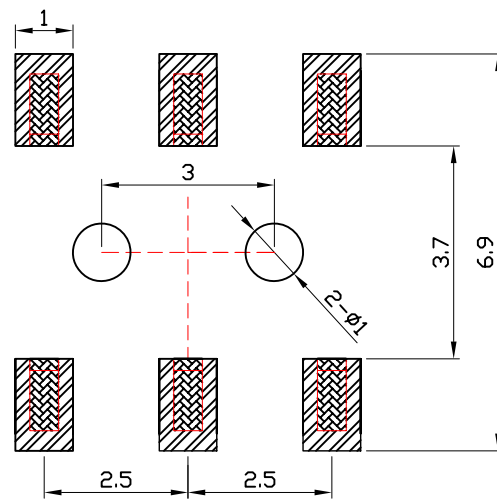
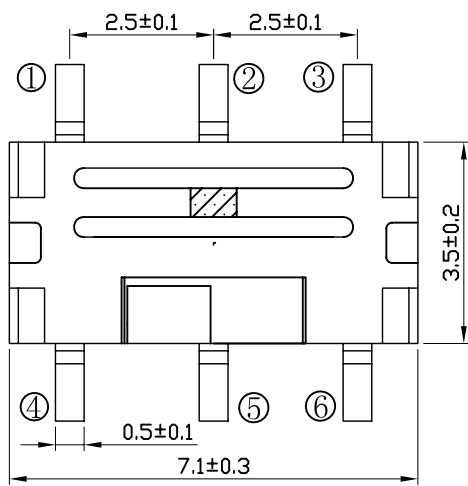
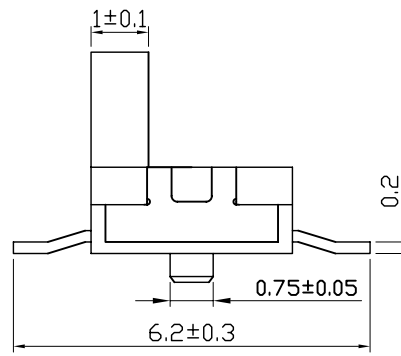
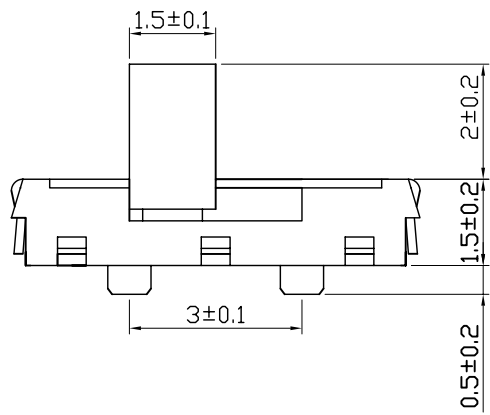

安装图 (PCB LAYOUT PLAN)

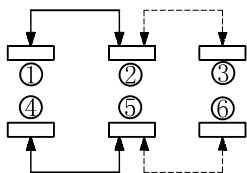

电路图 (CIRCUIT DIAGRAM)

LENGTH	TOLERANCE
$L < 5$	
$5 \leq L \leq 10$	
$10 < L \leq 15$	
$15 < L$	

型号

推柄长度

底座颜色

推柄颜色

动作力 (gf)

寿命

MSK-01P-G2/102

深圳市港源实业发展有限公司

备注

比例 1:1

制定

核对

审批

日期

尺寸单位

郭政

倪云鹏

林志明

2014. 12. 10

mm

此数据仅供参考，实际以样品为准

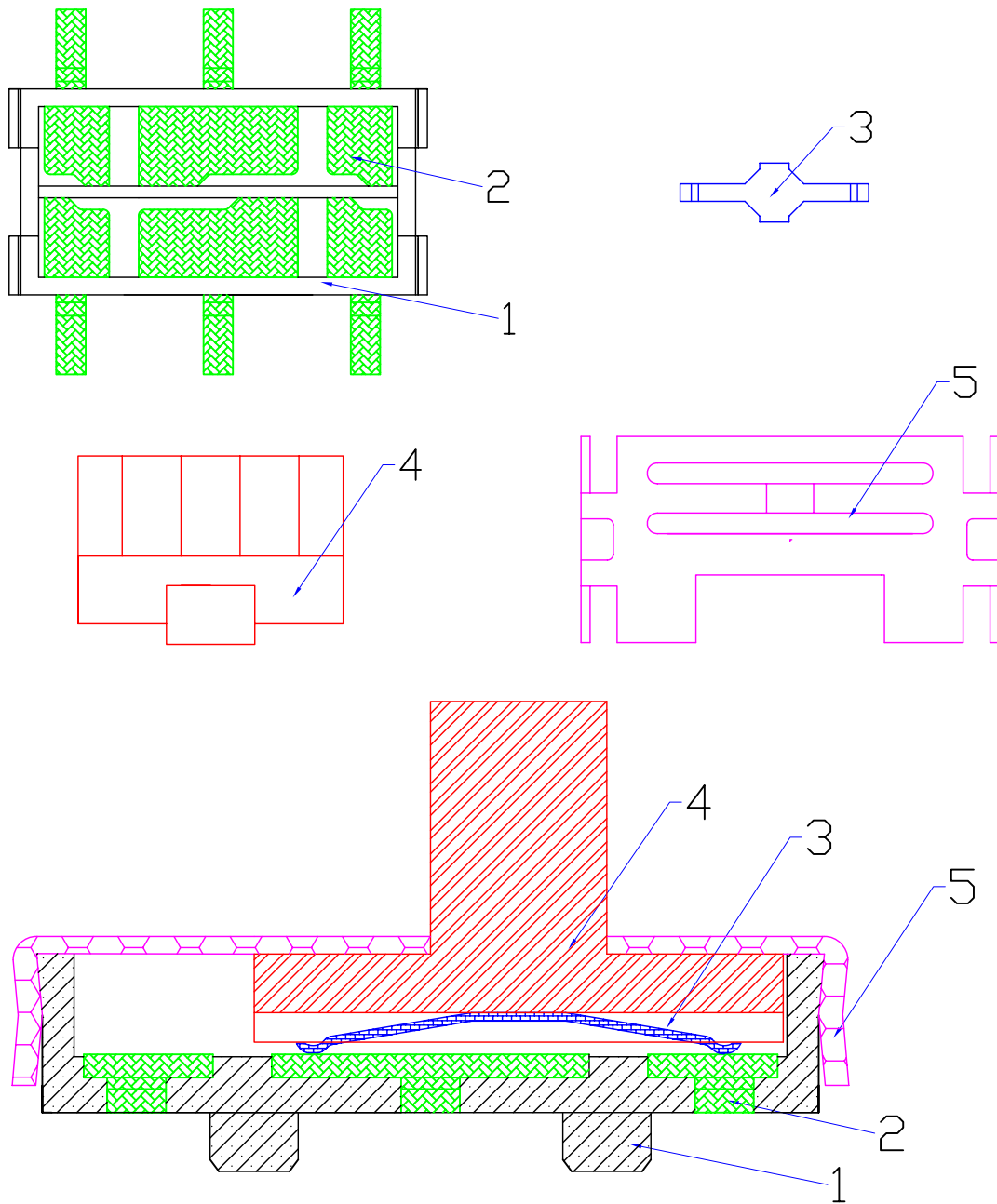

项目	零件	材料	颜色	数量
1	塑胶本体	LCP	黑色	1
2	五金端子	磷铜镀银	银白色	6
3	接触簧片	铍青铜镀银	银白色	2
4	塑胶推柄	PA46	黑色	1
5	五金盖板	不锈钢	本色	1
6				

深圳市港源实业发展有限公司

MSK-01P-G2/102

制定	核对	审批	日期	备注	此数据仅供参考，实际以样品为准
郭政	倪云鹏	林志明	2014.12.10		

深圳市港源实业发展有限公司		文件编号	
		发布日期	2014年12月10日
SPECIFICATION 规格书		第2版	1of3
产品名称:拨动开关		产品型号: MSK-01P-G2/102	
1:GENERAL SPECIFICATION 基本事项			
1.1	RATING (额定值): DC 12V 100mA		
1.2	PRACTICAL TEMPERATURE RANEG: - 10℃~+50℃. 使用温度范围: 在-10℃~+50℃温度内使用.		
1.3	STANDARD ATMOSPHEIC CONDITIONS : UNLESS OTHERWISE SPECIFIED. THE STANDARD RANGE OF ATMOSPHERIC CONDITIONS FOR MAKING MEASUREMENTS AND TESTS ARE AS FOLLOWS: (1) AMBIENT TEMPERATURE : 5℃ TO 35℃; (2) RELATIVE HUMIDITY : 45% TO 85%; (3) AIR PRESSURE : 86Kpa TO 106Kpa. 测试标准状态: 在沒有指定的情况下测试温度, 湿度, 气压如下: (1)温度为5~35℃; (2)湿度为45~85%; (3) 气压为86Kpa~106Kpa.		
2. ELECTRICAL CHARACTERISTICS (电气性能规格):			
ITEM	项目	TEST CONDITIONS 测试条件	PERFORMANCE (DATA) 规格(数据)
2.1	CONTACT RESISTANCE 接触电阻	MEASURED AT 1KHz SMALL CURRENT(100 mA OR LESS) 在1KHz微小电流(100mA 以下)测试.	100m Ω MAX. 100毫欧以下.
2.2	INSULATION RESISTANCE 绝缘电阻	APPLY A VOLTAGE OF 100V DC FOR 1 MIN. THE FOLLOWING CONTACE TEST METHOD: (1) BETWEEN BODY AND CONDUCTOR. (2) BETWEEN CONDUCTORS NOT TO BE CONTAC. 输入100V DC电压1分钟, 按以下接触方法测试: (1) 接触端子之间. (2) 胶座体和排脚之间.	50M Ω MIN. 50兆欧以上.
2.3	IELECTRIC STRENGTH 耐电压	AC 250V(50-60Hz) FOR 1 MIN TRIP CURRENT:0.5mA THE FOLLOWING CONTACE TEST METHOD: (1) BETWEEN TERMINALS. (2) BETWEEN INDIVIDUAL TERMINALS AND FRAME. 输入AC250V(50-60Hz) 电压, 1分钟感度电流为0.5mA, 接触测试方法如下: (1) 接触端子之间. (2) 外壳体和排脚之间.	WITHOUT DAMAGE TO PARTS ARCING OR BREAKDOWN ETC. 没有绝缘破坏等异常
3 .MECHANICAL CHARACTERISTICS (机械性能规格)			
ITEM	项目	TEST CONDITIONS 测试条件	PERFORMANCE (DATA) 规格(数据)
3.1	OPERATION FORCE 动作力	LATERAL PUSH (侧向推动)	PUSH FORCE (按压力度): 170gf ±50gf
3.2	TRAVEL TO CLOSURE 动作行程	IN THE HORIZONTAL DIRECTION SWITCH HANDLE OPRATION, WITH AN EQUAL TO 2TIMES THE THRUST OF THE SWITSH FORM ONE POSITION TO THE NEXT GEAR, MOVING DISTANCE MEASURING HANDLE. 在开关推柄运行的水平方向, 以一个等于2倍推力使开关从 一个档位运动到下一档位, 测量推柄的移动距离.	1.5mm ±0.2mm
3.3	STEM STRENGTH 操作部(柄) 强度	AND ALONG THE RUNNING DIRECTION AT APEX HANDLE(500g)ON THESTRENGTH TEST, TIME IS 30 SECONDS. 在推柄的先端沿运行方向加上(500g)力度测试, 时间为 30秒.	外观无异常, 满足于机械, 电气性能
PREPARED制定: 郭政		CHECKED 核对: 倪云鹏	APPROVED 审批: 林志明

深圳市港源实业发展有限公司

文件编号
发布日期

2014年12月10日

SPECIFICATION 规格书

第2版

2of3

产品名称: 拨动开关

产品型号: MSK-01P-G2/102

4. DURABILITY (耐久性):

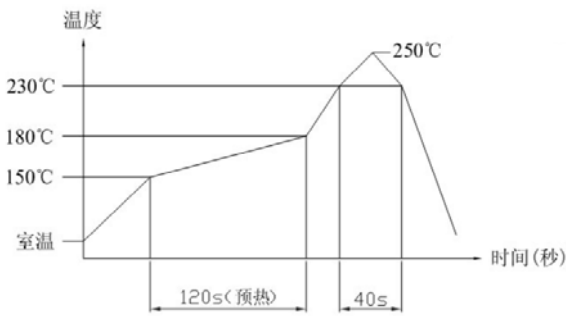
ITEM 项目	TEST CONDITIONS 测试条件	PERFORMANCE (DATA) 规格 (数据)
4.1 LIFE TEST 寿命试验	AN ACTUATOR SHALL BE WITH A THRUST OF NO GREAT THAN 1 TIMES SWITCH POWER TO 7000-10000 CYCLES AT A SPEED OF 30 CYCLES FOR 1 MIN. 操作者以每分钟30次的频率, 施加不大于开关1倍的推力做7000-10000次无负荷测试.	1) CONTACT RESISTANCE SHALL BE 500mΩ MAX. 2) LIFETIME: 7000-10000次 1) 接触电阻小于500mΩ. 2) 寿命: 7000-10000次
4.2 HEAT TEST 耐热实验	THE SWITCH SHALL BE STORED AT A TEMPERATURE OF 85±2°C FOR 96 HOURS. AND THEN IT SHALL BE SUBJECTED TO THE CONTROLLED RECOVERY CONDITIONS FOR 1 HOUR AFTER WHICH MEASUREMENT SHALL BE MADE. 放置在温度85±2°C中96小时后, 再放置正常室温中1小时后测定.	THERE SHALL BE NO DAMAGE ON APPEARANCE. MECHANICAL AND ELECTRICAL CHARACTERISTICS SHALL BE SATISFIED. 外观无异常, 满足于机械, 电气性能
4.3 COLD TEST 耐冷实验	THE SWITCH SHALL BE STORED AT A TEMPERATURE OF -25±3°C FOR 96 HOURS. AND THEN IT SHALL BE SUBJECTED TO THE CONTROLLED RECOVERY CONDITIONS FOR 1 HOUR AFTER WHICH MEASUREMENT SHALL BE MADE. 放置在温度-25±3°C中96小时后, 再放置正常室温中1小时后测定.	
4.4 HUMIDITY TEST 潮湿实验	THE SWITCH SHALL BE STORED AT A TEMPERATURE OF 40±2°C AND A HUMIDITY OF 80% TO 85% FOR 96 Hr. THEN THE JACK SHALL BE MAINTAINED AT STANDARD ATMOSPHERIC CONDITION FOR 1 Hr FOR OTHER PROCEDURES. 放置在40±2°C相对湿度为80~85%环境中96小时后, 再将样品放在正常室温中1小时后测定.	
4.5 SOLDERING CONDITIONS 焊锡条件	1) HAND SOLDERING 手焊: DVICE 工具: SOLDER IRON 电烙铁. 270°C MAX., 3 sec Max 2) REFLOW SOLDERING 回流焊: ≤250°C 	

PREPARED 制定: 郭政

CHECKED 核对: 倪云鹏

APPROVED 审批: 林志明

图1

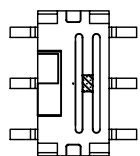

成品



图2

成品盘带

盘装物料标签

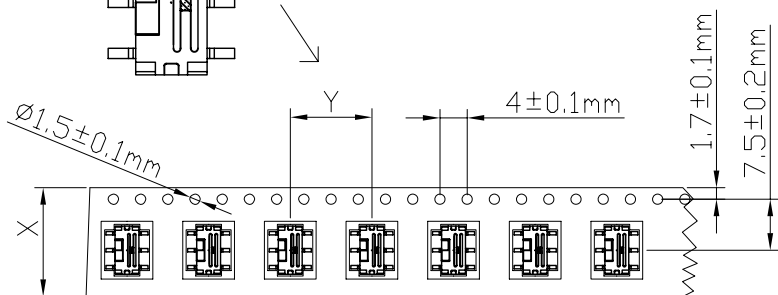

图3 盘装好的盘带

图5
外箱图4
内盒

内盒物料标签

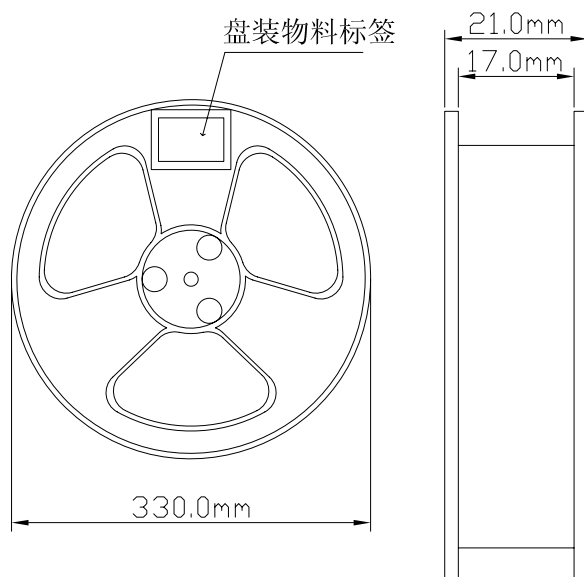
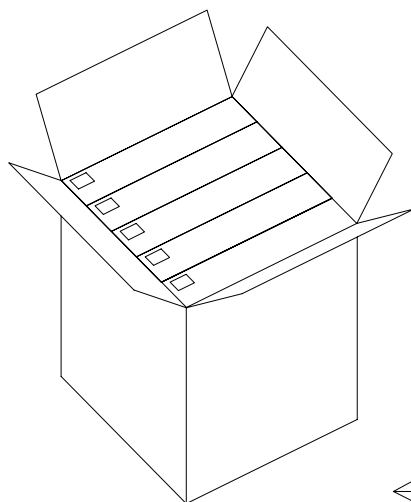

图6

外箱物料标签

说明:

- 1: 如图3, 盘装后贴上物料标签, 每盘带装1000pcs。
- 2: 如图4, 每盒装3盘, 装盒后贴上物料标签, 数量为3X1000pcs。
- 3: 如图5, 每箱装5盒, 数量为5X (3X1000pcs)
- 4: 如图6, 封箱贴上物料标签。

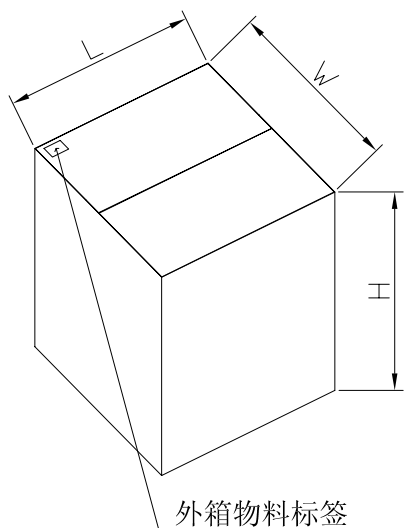
名称

型号

X

Y

L

W

H

包装示意图

MSK-01P-G2/102

16

12

365

365

380

深圳市港源实业发展有限公司

备注

制定

核对

审批

日期

尺寸单位

郭政

倪云鹏

林志明

2014. 12. 10

mm

此数据仅供参考, 实际以样品为准