

阅读申明

- 1.本站收集的数据手册和产品资料都来自互联网，版权归原作者所有。如读者和版权方有任何异议请及时告之，我们将妥善解决。
- 2.本站提供的中文数据手册是英文数据手册的中文翻译，其目的是协助用户阅读，该译文无法自动跟随原稿更新，同时也可能存在翻译上的不当。建议读者以英文原稿为参考以便获得更精准的信息。
- 3.本站提供的产品资料，来自厂商的技术支持或者使用者的心得体会等，其内容可能存在描述上的差异，建议读者做出适当判断。
- 4.如需与我们联系，请发邮件到marketing@iczoom.com，主题请标有“数据手册”字样。

Read Statement

1. The datasheets and other product information on the site are all from network reference or other public materials, and the copyright belongs to the original author and original published source. If readers and copyright owners have any objections, please contact us and we will deal with it in a timely manner.
2. The Chinese datasheets provided on the website is a Chinese translation of the English datasheets. Its purpose is for reader's learning exchange only and do not involve commercial purposes. The translation cannot be automatically updated with the original manuscript, and there may also be improper translations. Readers are advised to use the English manuscript as a reference for more accurate information.
3. All product information provided on the website refer to solutions from manufacturers' technical support or users the contents may have differences in description, and readers are advised to take the original article as the standard.
4. If you have any questions, please contact us at marketing@iczoom.com and mark the subject with "Datasheets" .

CAD GENERATED DRAWING - NO PENCIL CHANGES ALLOWED

% OF RATED CURRENT	OPENING TIME	
	MIN	MAX
110%	14,400 SEC.	-
200%	5 SEC.	100 SEC.
350%	0.2 SEC.	7 SEC.
600%	0.04 SEC.	1 SEC.

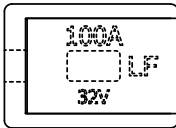

PART NUMBER	CURRENT RATING (A)	BODY COLOR
0294030.MXJ	30	PINK
0294040.MXJ	40	GREEN
0294050.MXJ	50	RED
0294060.MXJ	60	YELLOW
0294070.MXJ	70	BROWN
0294080.MXJ	80	BLACK
0294100.MXJ	100	BLUE
0294120.MXJ	120	WHITE

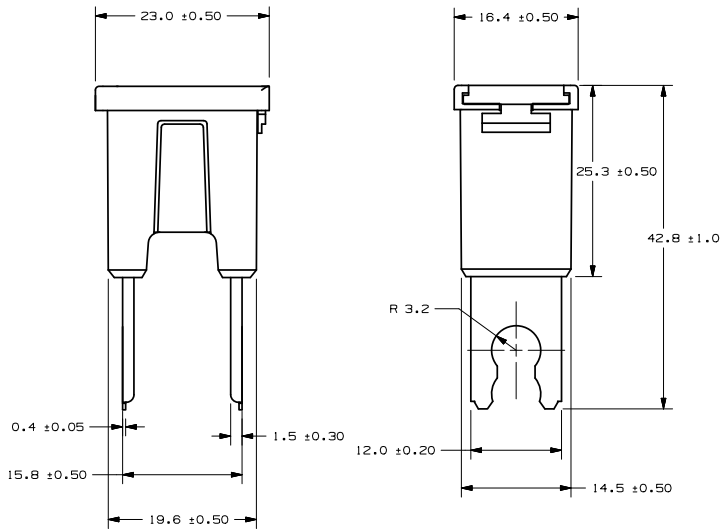

METRIC

UNLESS OTHERWISE SPECIFIED, DIMENSIONS ARE IN MILLIMETERS.				
UNLESS OTHERWISE SPECIFIED, DIMENSIONS DO NOT INCLUDE PLATING.				
UNLESS OTHERWISE SPECIFIED, DIMENSIONS DO NOT INCLUDE PLATING.				
©	DENOTES CRITICAL CHARACTERISTICS.			
CPK	DENOTES CPK DIMENSIONS. -MINIMUM CPK VALUE			
ST	DENOTES A CHARACTERISTIC THAT PROVIDES AN INDICATION OF PROCESS PERFORMANCE. PROCEDURE FOR MEASUREMENT IS LISTED IN THE LITTLEFUSE INSPECTION INSTRUCTIONS			
CP	DENOTES CP DIMENSIONS. -MINIMUM CP VALUE MUST BE WITHIN THE DIMENSIONAL LIMITATIONS SPECIFIED. DIMENSIONS ARE TO BE MEASURED TO ALLOW FOR MAXIMUM TOOL LIFE			
BILL OF MATERIAL				
NO	COMPONENT NO	DESCRIPTION	QTY/M	U/M
COPIES TO				
1	9	18	FINISH	
2	10	20	SCALE	
3	11	21	DATE	08/14/09
4	12	21	DATE	08/14/09
5	13	21	DATE	08/14/09
6	14	21	DATE	08/14/09
7	15	21	DATE	08/14/09
8	16	21	DATE	08/14/09
9	17	21	DATE	08/14/09
10	18	21	DATE	08/14/09
TOLERANCE UNLESS OTHERWISE SPECIFIED				
ONE PLACE DEC +/- .4				
TWO PLACE DEC +/- .25				
THREE PLACE DEC +/- .100				
ANGULAR +/- .1°				
TITLE BOLT DOWN HIGH CURRENT CARTRIDGE FUSE				
REVISION DRWG. NO. A OL-0294000.MXJ				
DATE 08/14/09				
REVISION 000762R-RELEASE GMB				
CHK APD				



REVISION DRWG. NO. A OL-0294000.MXJ