

阅读申明

- 1.本站收集的数据手册和产品资料都来自互联网，版权归原作者所有。如读者和版权方有任何异议请及时告之，我们将妥善解决。
- 2.本站提供的中文数据手册是英文数据手册的中文翻译，其目的是协助用户阅读，该译文无法自动跟随原稿更新，同时也可能存在翻译上的不当。建议读者以英文原稿为参考以便获得更精准的信息。
- 3.本站提供的产品资料，来自厂商的技术支持或者使用者的心得体会等，其内容可能存在描述上的差异，建议读者做出适当判断。
- 4.如需与我们联系，请发邮件到marketing@iczoom.com，主题请标有“数据手册”字样。

Read Statement

1. The datasheets and other product information on the site are all from network reference or other public materials, and the copyright belongs to the original author and original published source. If readers and copyright owners have any objections, please contact us and we will deal with it in a timely manner.
2. The Chinese datasheets provided on the website is a Chinese translation of the English datasheets. Its purpose is for reader's learning exchange only and do not involve commercial purposes. The translation cannot be automatically updated with the original manuscript, and there may also be improper translations. Readers are advised to use the English manuscript as a reference for more accurate information.
3. All product information provided on the website refer to solutions from manufacturers' technical support or users the contents may have differences in description, and readers are advised to take the original article as the standard.
4. If you have any questions, please contact us at marketing@iczoom.com and mark the subject with "Datasheets" .

UNCONTROLLED DOCUMENT

PART NUMBER
GT-RLSA3450

REV.
A

REV.	E.C.N. NUMBER AND REVISION COMMENTS	DATE
A	E.C.N. #11148.	12.18.06

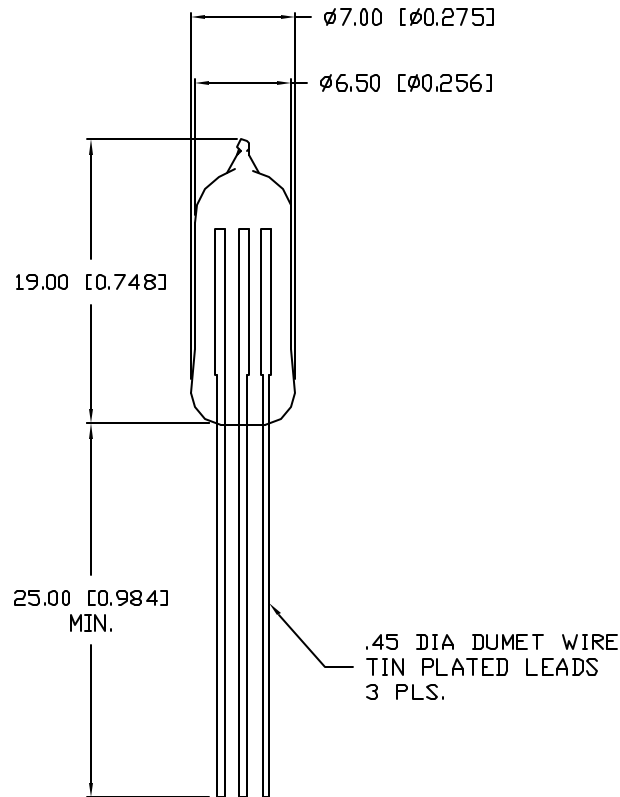

ELECTRICAL SPECIFICATIONS

CONDITION	UNITS	RATING
D.C. FIRING VOLTAGE:	(dv/dt 500V/S)	450V±15% D.C.
IMPULSE CURRENT:	(8/20μS)	1.5KA MAX.
IMPULSE CURRENT SURGE LIFE:	(10/1000μS 500A)	1000 TIMES MIN.
INSULATION RESISTANCE:	(100VDC)	10 ¹⁰ Ω
INTER-ELECTRODE CAPACITANCE:	(1.0 KHz)	1 PF MAX.

ENVIRONMENTAL SPECIFICATIONS PER MIL-STD 202

TEST	METHOD	CONDITION	RATING
VIBRATION TESTING:	204B	C	10-55Hz, .06DA
SHOCK	213A	C	100 g
HUMIDITY:	103B	B	95% Re, HUMIDITY
TEMPERATURE CYCLING:	102A	C	-65 TO +125 °C
BAROMETRIC PRESSURE:	105C	B	50,000 ft.
THERMAL SHOCK:	107	B	-65 TO +125 °C
SOLDERABILITY:	20B	B	

NOTE:

WHEN THE NEON LAMP IS ENERGIZED IN DARKNESS, THE STARTING VOLTAGE CAN RISE, DELAY THE LIGHT SURGE, OR NOT DISCHARGE. THEREFORE, THE BRIGHTNESS SHALL BE KEPT HIGHER THAN 10 LUX.



UNCONTROLLED DOCUMENT

*UNLESS OTHERWISE SPECIFIED TOLERANCES PER DECIMAL PRECISION ARE: X=±1 (±0.039), XX=±0.5 (±0.020), XXX=±0.25 (±0.010), XXXX=±0.127 (±0.005). LEAD SIZE=±0.05 (±0.002), LEAD LENGTH=±0.75 (±0.030), MIN.=^{+0.00}/_{-0.00} DECIMAL PRECISION MAX.=^{+0.00}/_{-0.00} DECIMAL PRECISION

REV. A	PART NUMBER GT-RLSA3450
-----------	----------------------------

CONFIDENTIAL INFORMATION
THE INFORMATION CONTAINED IN THIS DOCUMENT IS THE PROPERTY OF LUMEX INC. EXCEPT AS SPECIFICALLY AUTHORIZED IN WRITING BY LUMEX INC, THE HOLDER OF THIS DOCUMENT SHALL KEEP ALL INFORMATION CONTAINED HEREIN CONFIDENTIAL AND SHALL PROTECT SAME IN WHOLE OR IN PART FROM DISCLOSURE AND DISSEMINATION TO ALL THIRD PARTIES.



290 E. HELEN ROAD
PALATINE, IL 60067-6976
PHONE: +1.847.359.2790
US WEB: www.lumex.com
TW WEB: www.lumex.com.tw

LIGHT DUTY ARRESTOR, THREE LEAD (450 VDC)

RELIABILITY NOTE
OUR MANY YEARS OF EXPERIENCE DATA ACCUMULATION INDICATE THAT SOLDER HEAT IS A MAJOR CAUSE OF EARLY AND FUTURE FAILURE. PLEASE PAY ATTENTION TO YOUR SOLDERING PROCESS.

DRAWN BY: JC	CHECKED BY:	APPROVED BY:	DATE: 12.18.06
			PAGE: 1 OF 1
			SCALE: N/A