

## 阅读申明

- 1.本站收集的数据手册和产品资料都来自互联网，版权归原作者所有。如读者和版权方有任何异议请及时告之，我们将妥善解决。
- 2.本站提供的中文数据手册是英文数据手册的中文翻译，其目的是协助用户阅读，该译文无法自动跟随原稿更新，同时也可能存在翻译上的不当。建议读者以英文原稿为参考以便获得更精准的信息。
- 3.本站提供的产品资料，来自厂商的技术支持或者使用者的心得体会等，其内容可能存在描述上的差异，建议读者做出适当判断。
- 4.如需与我们联系，请发邮件到marketing@iczoom.com，主题请标有“数据手册”字样。

## Read Statement

1. The datasheets and other product information on the site are all from network reference or other public materials, and the copyright belongs to the original author and original published source. If readers and copyright owners have any objections, please contact us and we will deal with it in a timely manner.
2. The Chinese datasheets provided on the website is a Chinese translation of the English datasheets. Its purpose is for reader's learning exchange only and do not involve commercial purposes. The translation cannot be automatically updated with the original manuscript, and there may also be improper translations. Readers are advised to use the English manuscript as a reference for more accurate information.
3. All product information provided on the website refer to solutions from manufacturers' technical support or users the contents may have differences in description, and readers are advised to take the original article as the standard.
4. If you have any questions, please contact us at marketing@iczoom.com and mark the subject with "Datasheets" .

### Multilayer Varistor for ESD pulse

Series **EZJZ** : For high speed signal line  
(ZnO:Zinc Oxide) (Small capacitance)

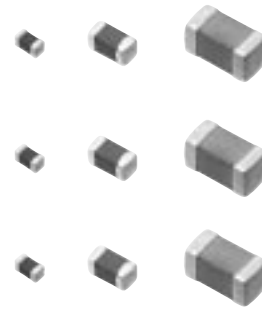

#### ■ Features

- Multilayer monolithic ceramic construction
- Excellent solderability and superior heat resistance
- Large surge current and energy capabilities in withstanding small size.

#### ● Series EZJZ

- Multilayer varistor of Zinc oxide ceramic. suppresses the pulse noise(ESD, burst-noise) and protects the equipment from the transient surge.
- This Varistor is suitable for high-speed signal line due to small capacitance.

#### ■ Precautions for Handling see Page 112 to 118

#### ■ Packing method see Page 111, 182

#### ■ Explanation of Part Numbers

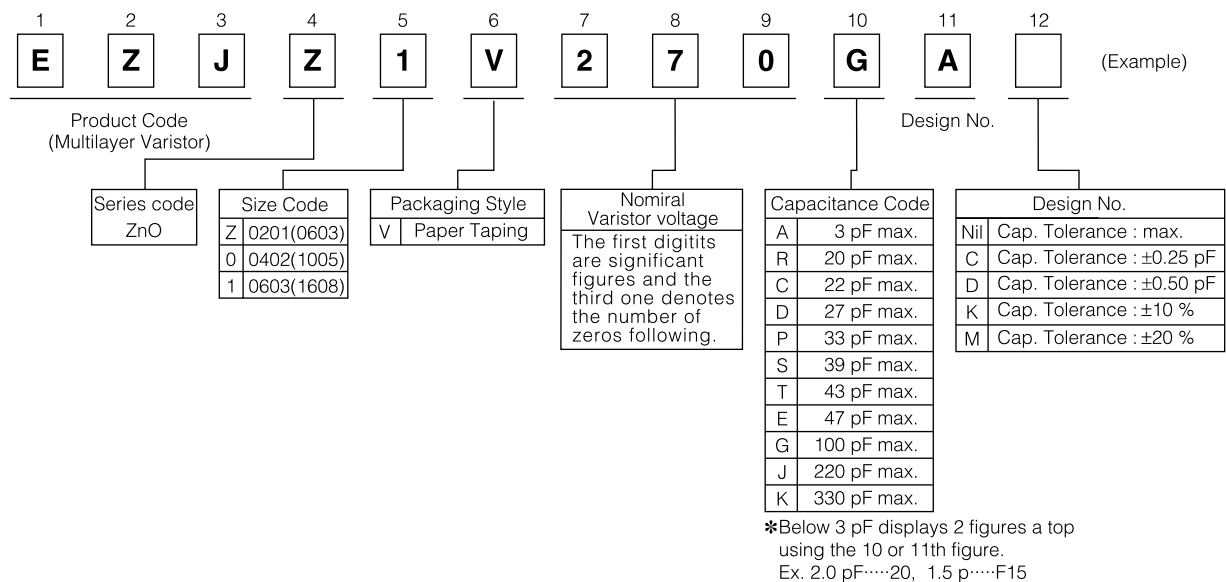

#### ■ Construction

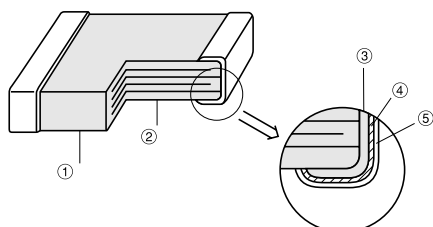

No	Name	
①	Semiconductive Ceramics	
②	Inner electrode	
③	Electrode	Substrate electrode
④		Intermediate electrode
⑤		External electrode

■ Dimension in mm(not to scale)

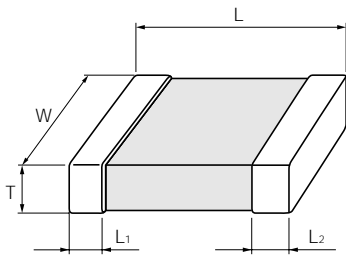

(Unit:mm)

Size Code (EIA)	Part Numbers	L	W	T	L1, L2
0201	EZJZZ□□□□□A	0.60±0.03	0.30±0.03	0.30±0.03	0.15±0.05
0402	EZJZ0□□□□□A	1.00±0.50	0.50±0.05	0.50±0.05	0.2±0.1
0603	EZJZ1□□□□□A	1.6±0.1	0.8±0.1	0.8±0.1	0.3±0.2

■ Ratings and Characteristics

Type	Size Code (EIA)	Part No.	Maximum Allowable Voltage	Varistor Voltage @ 1mA	Capacitance @ 1 MHz	Maximum Peak Current @ 8/20 μs	Maximum ESD IEC61000-4-2
Ultra low capacitance	0201	EZJZZV800AA	DC 5 V	80 V	3 pF max.	—	Contact Discharge Voltage: 8 kV Air Gap Discharge Voltage: 15 kV
		EZJZ0V80015D	DC 5 V	80 V	1.5±0.5 pF	—	
	0402	EZJZ0V500AA	DC 5 V	50 V	3 pF max.	—	
		EZJZ0V800AA	DC 18 V	80 V	3 pF max.	—	
		EZJZ0V171AA	DC 18 V	170 V	3 pF max.	—	
	0603	EZJZ1V500AA	DC 5 V	50 V	3 pF max.	—	
		EZJZ1V800AA	DC 18 V	80 V	3 pF max.	—	
EZJZ1V171AA		DC 18 V	170 V	3 pF max.	—		
Low capacitance	0201	EZJZZV120EA	DC 6.7 V	12 V	47 pF max.	1 A	
		EZJZZV270RA	DC 16 V	27 V	20 pF max.	1 A	
	0402	EZJZ0V120JA	DC 6.7 V	12 V	220 pF max.	10 A	
		EZJZ0V270RA	DC 16 V	27 V	20 pF max.	3 A	
		EZJZ0V270EA	DC 16 V	27 V	47 pF max.	10 A	
	0603	EZJZ1V120KA	DC 6.7 V	12 V	330 pF max.	20 A	
		EZJZ1V270GA	DC 16 V	27 V	100 pF max.	20 A	
		EZJZ1V330GA	DC 26 V	33 V	100 pF max.	20 A	

● Operating Temperature Range: -40 to 85 °C

■ Typical Characteristics

● Voltage vs. Current

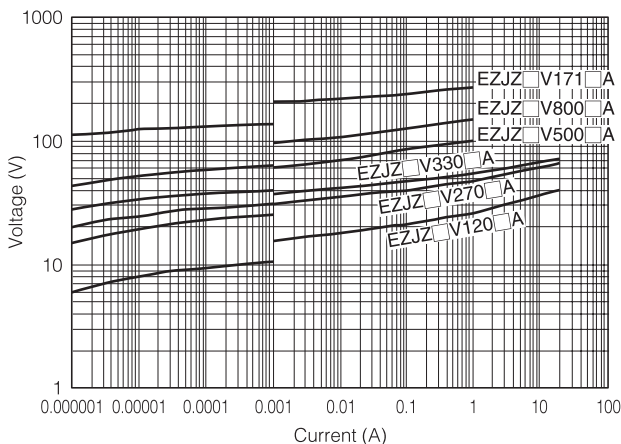

■ Frequency Characteristics

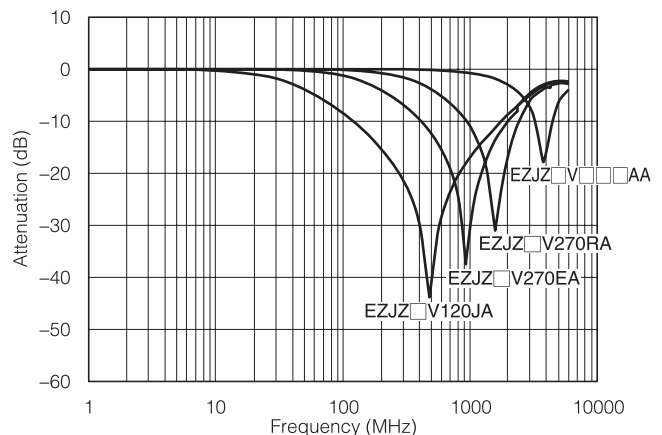

### ■ Packaging Specifications

#### ● Standard Packing Quantity

Series	Size Code (EIA)	Thickness	Paper taping	Embossed taping
EZJZ	0201	0.3 mm	Pitch: 2 mm 15,000 pcs./reel	—
	0402	0.5 mm	Pitch: 2 mm 10,000 pcs./reel	—
	0603	0.8 mm	Pitch: 4 mm 4,000 pcs./reel	—
	2 Array Type	0.6 mm	Pitch: 4 mm 4,000 pcs./reel	—
	4 Array Type	0.85 mm	Pitch: 4 mm 4,000 pcs./reel	—
EZJS	0603	0.8 mm	Pitch: 4 mm 4,000 pcs./reel	—
	0805	0.8 mm	Pitch: 4 mm 5,000 pcs./reel	—
		1.25 mm	—	Pitch: 4 mm 2,000 pcs./reel

#### ● Paper Taping

P<sub>1</sub>: 2mm

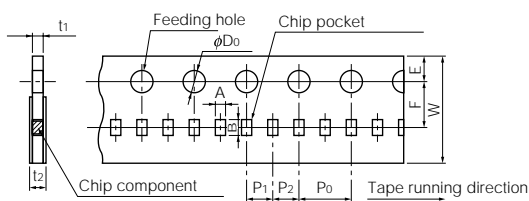

(Unit: mm)

Symbol	A	B	W	F	E	P <sub>1</sub>	P <sub>2</sub>	P <sub>0</sub>	φD	t <sub>1</sub>	t <sub>2</sub>
0201	0.37 ±0.03	0.67 ±0.03	8.0 ±0.2	3.50 ±0.05	1.75 ±0.10	2.00 ±0.05	2.00 ±0.05	4.0 ±0.05	1.5 +0.1 0	0.5 max.	0.8 max.
0402	0.62 ±0.05	1.12 ±0.05	8.0 ±0.2	3.50 ±0.05	1.75 ±0.10	2.00 ±0.05	2.00 ±0.05	4.0 ±0.05	1.5 +0.1 0	0.7 max.	1.0 max.

P<sub>1</sub>: 4mm

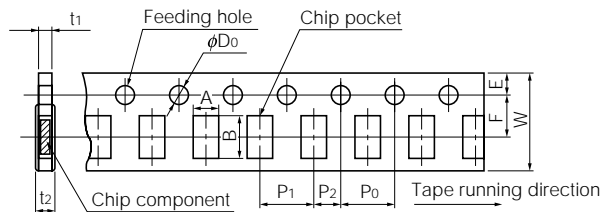

(Unit: mm)

Symbol	A	B	W	F	E	P <sub>1</sub>	P <sub>2</sub>	P <sub>0</sub>	φD	t <sub>1</sub>	t <sub>2</sub>
0603	1.18 ±0.10	1.63 ±0.10	8.0 ±0.2	3.50 ±0.05	1.75 ±0.10	4.0 ±0.1	2.00 ±0.05	4.0 ±0.1	1.5 +0.1	1.1 max.	1.4 max.
0805 4 Array Type	1.65 ±0.2	2.4 ±0.2	8.0 ±0.2	3.50 ±0.05	1.75 ±0.10	4.0 ±0.1	2.00 ±0.05	4.0 ±0.1	1.5 +0.1	1.1 max.	1.4 max.
0504 2 Array Type	1.0 ±0.1	1.8 ±0.1	8.0 ±0.2	3.50 ±0.05	1.75 ±0.10	4.0 ±0.1	2.00 ±0.05	4.0 ±0.1	1.5 +0.1	1.1 max.	1.4 max.

#### ● Embossed Taping

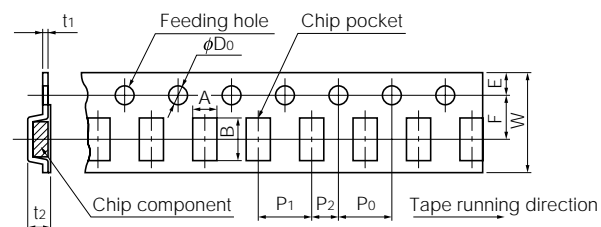

(Unit: mm)

Symbol	A	B	W	F	E	P <sub>1</sub>	P <sub>2</sub>	P <sub>0</sub>	φD	t <sub>1</sub>	t <sub>2</sub>
0805	1.55 ±0.20	2.35 ±0.20	8.0 ±0.2	3.50 ±0.05	1.75 ±0.10	4.0 ±0.1	2.00 ±0.05	4.0 ±0.1	1.5 +0.1 0	0.6 max.	1.5 max.

#### ● Reel

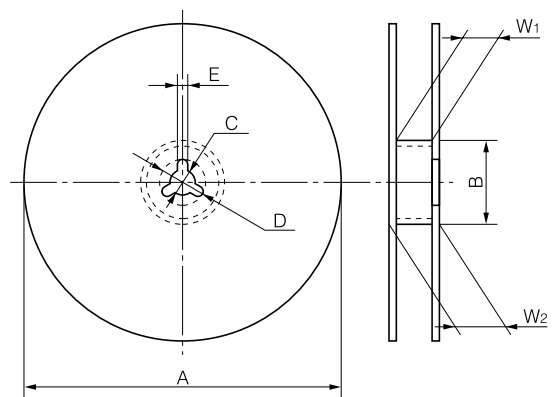

Symbol	A	B	C	D	E	W <sub>1</sub>	W <sub>2</sub>
Dim. (mm)	φ180 <sup>-0.1</sup>	φ60.0±0.5	13.0±0.5	21.0±0.8	2.0±0.5	9.0±0.3	11.4±1.00

#### ● Leader Part and Taped End

Tape end

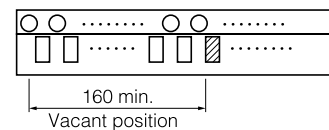

Leader part

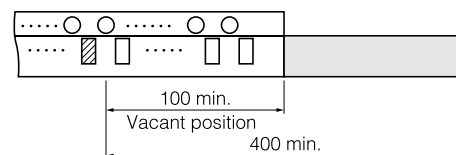

Unit : mm