

阅读申明

- 1.本站收集的数据手册和产品资料都来自互联网，版权归原作者所有。如读者和版权方有任何异议请及时告之，我们将妥善解决。
- 2.本站提供的中文数据手册是英文数据手册的中文翻译，其目的是协助用户阅读，该译文无法自动跟随原稿更新，同时也可能存在翻译上的不当。建议读者以英文原稿为参考以便获得更精准的信息。
- 3.本站提供的产品资料，来自厂商的技术支持或者使用者的心得体会等，其内容可能存在描述上的差异，建议读者做出适当判断。
- 4.如需与我们联系，请发邮件到marketing@iczoom.com，主题请标有“数据手册”字样。

Read Statement

1. The datasheets and other product information on the site are all from network reference or other public materials, and the copyright belongs to the original author and original published source. If readers and copyright owners have any objections, please contact us and we will deal with it in a timely manner.
2. The Chinese datasheets provided on the website is a Chinese translation of the English datasheets. Its purpose is for reader's learning exchange only and do not involve commercial purposes. The translation cannot be automatically updated with the original manuscript, and there may also be improper translations. Readers are advised to use the English manuscript as a reference for more accurate information.
3. All product information provided on the website refer to solutions from manufacturers' technical support or users the contents may have differences in description, and readers are advised to take the original article as the standard.
4. If you have any questions, please contact us at marketing@iczoom.com and mark the subject with "Datasheets" .

Structure Silicone monolithic integrated circuit

Product name Audio sound processor for TV

Model Name **BD3869AF/BD3869AS**

●Features

1. Built-in loudness linked to volume attenuation amount
2. Maximum of 3 channels can be used simultaneously with I²C BUS control at the control voltage of 3.3V-5.5V
3. Use the Bi-CMOS process

●Absolute Maximum Ratings

Parameter		Symbol	Limits	Unit
Applied voltage		VCC	10.0	V
Input voltage		Vin	VCC+0.3~GND-0.3	V
Power Dissipation	BD3869AF	Pd	680 *1	mW
	BD3869AS		750 *2	
Operating temperature		Topr	-40~+85 *3	°C
Storage temperature		Tastg	-55~+150	°C

*1 At Ta=25°C or higher, this value is decreased to 5.5mW/°C. Thermal resistance $\theta_{ja} = 181.8$ (°C/W).

*2 At Ta=25°C or higher, this value is decreased to 6.0mW/°C. Thermal resistance $\theta_{ja} = 166.7$ (°C/W).

When Rohm standard board is mounted.

Rohm standard board: size: 70 × 70 × 1.6 (mm³)

material: FR4 glass-epoxy substrate (copper foil area: not more than 3%).

*3 As long as voltage stays within operating voltage range, certain circuit operation is guaranteed in the operating temperature range.

Allowable loss conditions are related to temperature, to which care must be taken.

In addition though the standard value of its electrical characteristics cannot be guaranteed under the conditions other than those specified, original functions are maintained.

●Operating Voltage Range

Parameter	Symbol	Min.	Typ.	Max.	Unit
Power supply voltage *4	VCC	5.3	9.0	9.5	V

Basic operation shall be available at Ta=25°C.

*4 As long as temperature components must be set in accordance with the operating voltage and temperature ranges before using this IC.

In addition, though the standard value of its electrical characteristics cannot be guaranteed under the conditions other than those specified, original functions are maintained.

●Function

Function	Specifications
Front volume	From 0dB to -89dB(1dB step)
Loudness	Volume attenuation linked type
Bass	± 14 dB(2dB Step),
Treble	± 14 dB(2dB Step),
Rear Volume	From 0dB to-20dB(1dB step), -25dB,-30dB,-35dB-45dB,-60dB, MUTE

●Electrical characteristics

Unless specified: $T_a=25^\circ\text{C}$, $V_{CC}=9\text{V}$, $f=1\text{kHz}$, $V_{in}=1\text{V}_{rms}$, $R_g=600\Omega$, $R_L=10\text{k}\Omega$, A single input, Input gain 0dB, Volume = 0dB, middle 0dB, bass = 0dB, treble = 0dB, fader 0dB

Parameter	Symbol	Limits			Unit	Conditions
		Min.	Typ.	Max.		
Circuit current upon no signal	IQ	-	3	7	mA	$V_{in}=0\text{V}_{rms}$
Maximum input voltage	VIM	2.2	2.5	-	V _{rms}	Front Volume = -6dB THD(V_{out})=1%
Maximum output voltage	VOM	2.1	2.3	-	V _{rms}	THD=1%
Voltage gain	GV	-2	0	2	dB	$G_v=20\log(V_{out}/V_{in})$
Channel balance	CB	-1.5	0	1.5	dB	$CB = G_{v1}-G_{v2}$
Total harmonic distortion	THD	-	0.01	0.2	%	$V_{out}=1\text{V}_{rms}$ BPF=400-30kHz
Output noise voltage	VNO	-	2.3	15	μV_{rms}	BPF = IHF-A $R_g=0\Omega$
Residual noise voltage	VMNO	-	1.4	10	μV_{rms}	Front Volume = -89dB Rear Volume = $-\infty$, BPF = IHF-A $R_g=0\Omega$
Cross talk 1ch→2ch	CT	70	95	-	dB	$CT = 20\log(V_{in}/V_{out})$, BPF=IHF-A
Maximum attenuation	ATT_{MAX}	-	-114	-90	dB	Front Volume = -89dB Rear Volume = $-\infty$, $ATT_{MAX}=20\log(V_{out}/V_{in})$ BPF=IHF-A

● Dimensional outline drawing

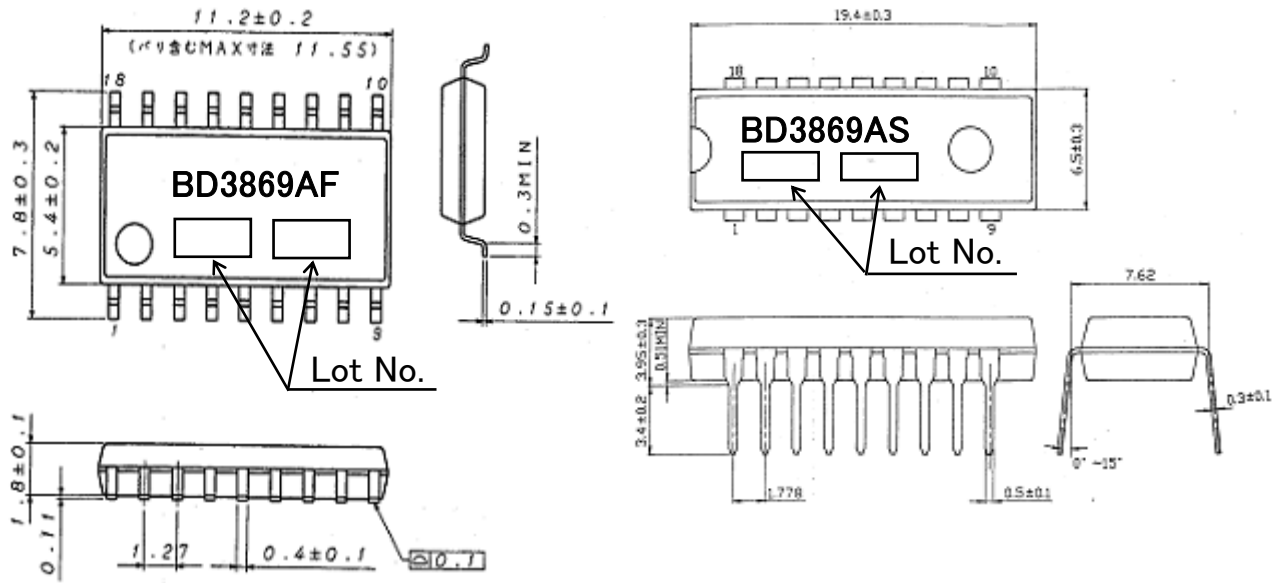

SOP-18 (Unit : mm)

SDIP-18 (Unit : mm)

● Block diagram

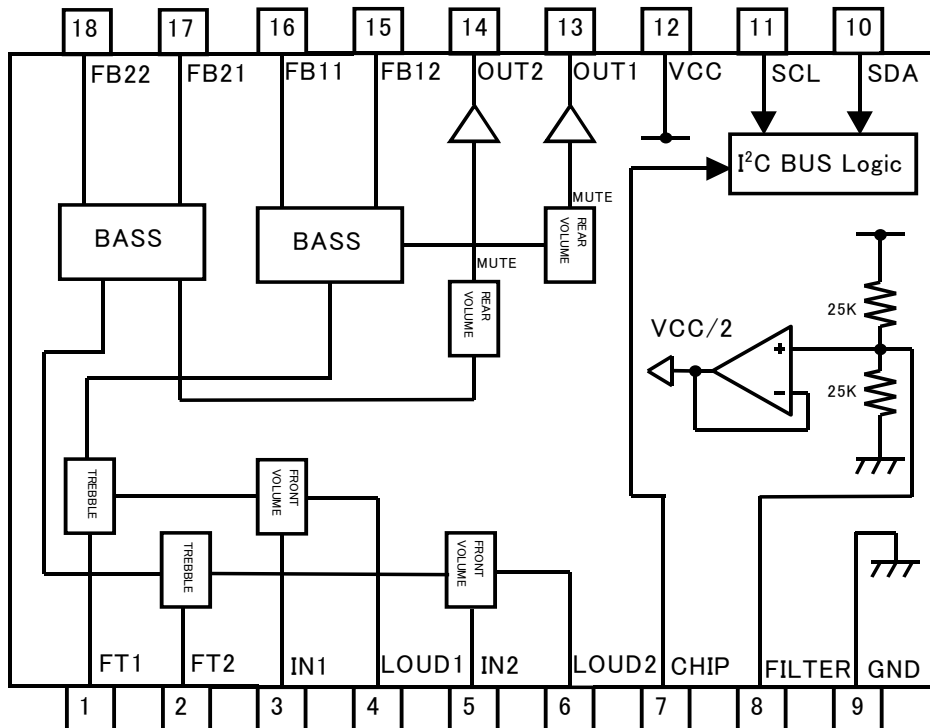

●Cautions on use

- (1) Numbers and data in entries are representative design values and are not guaranteed values of the items.
- (2) Although we are confident in recommending the sample application circuits, carefully check their characteristics further when using them. When modifying externally attached component constants before use, determine them so that they have sufficient margins by taking into account variations in externally attached components and the Rohm LSI, not only for static characteristics but also including transient characteristics.
- (3) Absolute maximum ratings
If applied voltage, operating temperature range, or other absolute maximum ratings are exceeded, the LSI may be damaged. Do not apply voltages or temperatures that exceed the absolute maximum ratings. If you think of a case in which absolute maximum ratings are exceeded, enforce fuses or other physical safety measures and investigate how not to apply the conditions under which absolute maximum ratings are exceeded to the LSI.
- (4) GND potential
Make the GND pin voltage such that it is the lowest voltage even when operating below it. Actually confirm that the voltage of each pin does not become a lower voltage than the GND pin, including transient phenomena.
- (5) Thermal design
Perform thermal design in which there are adequate margins by taking into account the allowable power dissipation in actual states of use.
- (6) Shorts between pins and misinstallation
When mounting the LSI on a board, pay adequate attention to orientation and placement discrepancies of the LSI. If it is misinstalled and the power is turned on, the LSI may be damaged. It also may be damaged if it is shorted by a foreign substance coming between pins of the LSI or between a pin and a power supply or a pin and a GND.
- (7) Operation in strong magnetic fields
Adequately evaluate use in a strong magnetic field, since there is a possibility of malfunction.

Notes

No copying or reproduction of this document, in part or in whole, is permitted without the consent of ROHM Co.,Ltd.

The content specified herein is subject to change for improvement without notice.

The content specified herein is for the purpose of introducing ROHM's products (hereinafter "Products"). If you wish to use any such Product, please be sure to refer to the specifications, which can be obtained from ROHM upon request.

Examples of application circuits, circuit constants and any other information contained herein illustrate the standard usage and operations of the Products. The peripheral conditions must be taken into account when designing circuits for mass production.

Great care was taken in ensuring the accuracy of the information specified in this document. However, should you incur any damage arising from any inaccuracy or misprint of such information, ROHM shall bear no responsibility for such damage.

The technical information specified herein is intended only to show the typical functions of and examples of application circuits for the Products. ROHM does not grant you, explicitly or implicitly, any license to use or exercise intellectual property or other rights held by ROHM and other parties. ROHM shall bear no responsibility whatsoever for any dispute arising from the use of such technical information.

The Products specified in this document are intended to be used with general-use electronic equipment or devices (such as audio visual equipment, office-automation equipment, communication devices, electronic appliances and amusement devices).

The Products specified in this document are not designed to be radiation tolerant.

While ROHM always makes efforts to enhance the quality and reliability of its Products, a Product may fail or malfunction for a variety of reasons.

Please be sure to implement in your equipment using the Products safety measures to guard against the possibility of physical injury, fire or any other damage caused in the event of the failure of any Product, such as derating, redundancy, fire control and fail-safe designs. ROHM shall bear no responsibility whatsoever for your use of any Product outside of the prescribed scope or not in accordance with the instruction manual.

The Products are not designed or manufactured to be used with any equipment, device or system which requires an extremely high level of reliability the failure or malfunction of which may result in a direct threat to human life or create a risk of human injury (such as a medical instrument, transportation equipment, aerospace machinery, nuclear-reactor controller, fuel-controller or other safety device). ROHM shall bear no responsibility in any way for use of any of the Products for the above special purposes. If a Product is intended to be used for any such special purpose, please contact a ROHM sales representative before purchasing.

If you intend to export or ship overseas any Product or technology specified herein that may be controlled under the Foreign Exchange and the Foreign Trade Law, you will be required to obtain a license or permit under the Law.



Thank you for your accessing to ROHM product informations.
More detail product informations and catalogs are available, please contact us.

ROHM Customer Support System

<http://www.rohm.com/contact/>