

阅读申明

- 1.本站收集的数据手册和产品资料都来自互联网，版权归原作者所有。如读者和版权方有任何异议请及时告之，我们将妥善解决。
- 2.本站提供的中文数据手册是英文数据手册的中文翻译，其目的是协助用户阅读，该译文无法自动跟随原稿更新，同时也可能存在翻译上的不当。建议读者以英文原稿为参考以便获得更精准的信息。
- 3.本站提供的产品资料，来自厂商的技术支持或者使用者的心得体会等，其内容可能存在描述上的差异，建议读者做出适当判断。
- 4.如需与我们联系，请发邮件到marketing@iczoom.com，主题请标有“数据手册”字样。

Read Statement

1. The datasheets and other product information on the site are all from network reference or other public materials, and the copyright belongs to the original author and original published source. If readers and copyright owners have any objections, please contact us and we will deal with it in a timely manner.
2. The Chinese datasheets provided on the website is a Chinese translation of the English datasheets. Its purpose is for reader's learning exchange only and do not involve commercial purposes. The translation cannot be automatically updated with the original manuscript, and there may also be improper translations. Readers are advised to use the English manuscript as a reference for more accurate information.
3. All product information provided on the website refer to solutions from manufacturers' technical support or users the contents may have differences in description, and readers are advised to take the original article as the standard.
4. If you have any questions, please contact us at marketing@iczoom.com and mark the subject with "Datasheets" .



2.5V Wide Range Frequency Clock Driver (45MHz - 233MHz)

Recommended Application:

- DDR Memory Modules / Zero Delay Board Fan Out
- Provides complete DDR registered DIMM solution with ICSSTVF16857, ICSSTVF16859 or ICSSTV32852

Product Description/Features:

- Low skew, low jitter PLL clock driver
- 1 to 10 differential clock distribution (SSTL_2)
- Feedback pins for input to output synchronization
- PD# for power management
- Spread Spectrum-tolerant inputs
- Auto PD when input signal removed

Specifications:

- Meets PC3200 Class A+ specification for DDR-I 400 support
- Covers all DDRI speed grades

Switching Characteristics:

- CYCLE - CYCLE jitter: <50ps
- OUTPUT - OUTPUT skew: <40ps
- Period jitter: ±30ps

Functionality

INPUTS				OUTPUTS				PLL State
AVDD	PD#	CLK_INT	CLK_INC	CLKT	CLKC	FB_OUTT	FB_OUTC	
GND	H	L	H	L	H	L	H	Bypassed/off
GND	H	H	L	H	L	H	L	Bypassed/off
2.5V (nom)	L	L	H	Z	Z	Z	Z	off
2.5V (nom)	L	H	L	Z	Z	Z	Z	off
2.5V (nom)	H	L	H	L	H	L	H	on
2.5V (nom)	H	H	L	H	L	H	L	on
2.5V (nom)	X	<20MHz ⁽¹⁾		Z	Z	Z	Z	off

Pin Configuration

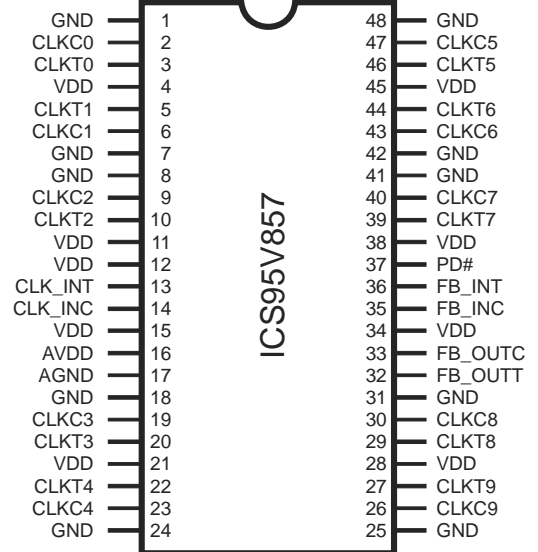

48-Pin TSSOP/TVSOP

6.10 mm Body, 0.50 mm Pitch = TSSOP
4.40 mm Body, 0.40 mm Pitch = TVSOP

Block Diagram

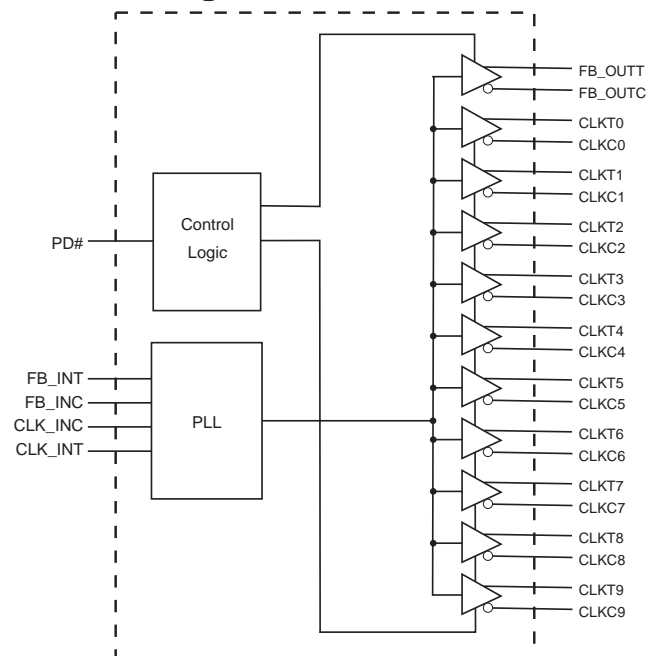



Pin Configuration

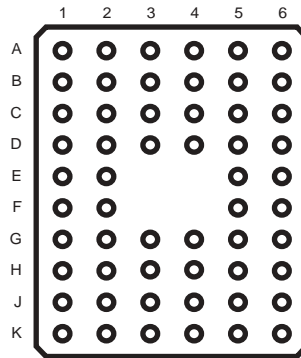

56-Ball BGA

Top View

	1	2	3	4	5	6
A	CLKT0	CLKC0	GND	GND	CLKC5	CLKT5
B	CLKC1	CLKT1	VDD	VDD	CLKT6	CLKC6
C	GND	GND	NC	NC	GND	GND
D	CLKT2	CLKC2	NC	NC	CLKC7	CLKT7
E	VDD	VDD	NB	NB	VDD	PD#
F	CLK_INT	CLK_INC	NB	NB	FB_INC	FB_INT
G	VDD	AVDD	NC	NC	FB_OUTC	VDD
H	AGND	GND	NC	NC	GND	FB_OUTT
J	CLKC3	CLKT3	VDD	VDD	CLKT8	CLKC8
K	CLKT4	CLKC4	GND	GND	CLKC9	CLKT9

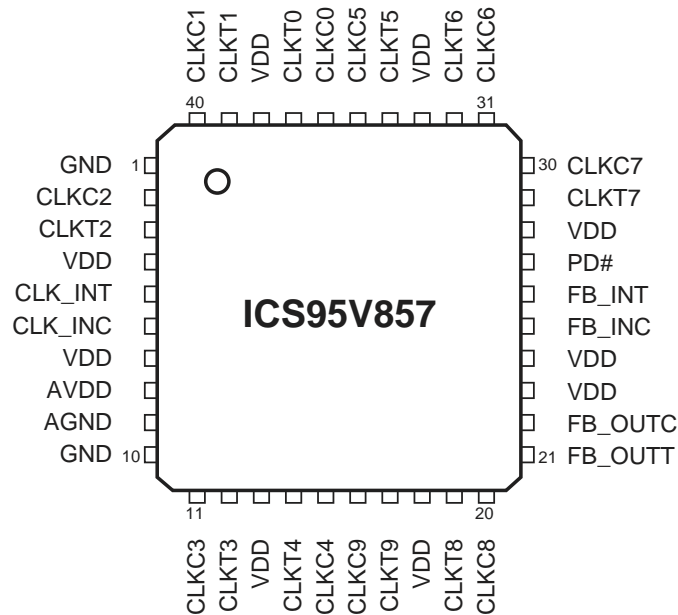

40-Pin MLF



Pin Descriptions

PIN NAME	TYPE	DESCRIPTION
VDD	PWR	Power supply, 2.5V
GND	PWR	Ground
AVDD	PWR	Analog power supply, 2.5V
AGND	PWR	Analog ground
CLKT(9:0)	OUT	"True" Clock of differential pair outputs
CLKC(9:0)	OUT	"Complementary" clocks of differential pair outputs
CLK_INC	IN	"Complementary" reference clock input
CLK_INT	IN	"True" reference clock input
FB_OUTC	OUT	"Complementary" Feedback output, dedicated for external feedback. It switches at the same frequency as the CLK. This output must be wired to FB_INC
FB_OUTT	OUT	"True" Feedback output, dedicated for external feedback. It switches at the same frequency as the CLK. This output must be wired to FB_INT
FB_INT	IN	"True" Feedback input, provides feedback signal to the internal PLL for synchronization with CLK_INT to eliminate phase error
FB_INC	IN	"Complementary" Feedback input, provides signal to the internal PLL for synchronization with CLK_INC to eliminate phase error
PD#	IN	Power Down. LVCMOS input

This PLL Clock Buffer is designed for a V_{DD} of 2.5V, an AV_{DD} of 2.5V and differential data input and output levels.

The **ICS95V857** is a zero delay buffer that distributes a differential clock input pair (CLK_INC, CLK_INT) to ten differential pair of clock outputs (CLKT[0:9], CLKC[0:9]) and one differential pair feedback clock output (FB_OUT, FB_OUTC). The clock outputs are controlled by the input clocks (CLK_INC, CLK_INT), the feedback clocks (FB_INT, FB_INC), the 2.5-V LVCMOS input (PD#) and the Analog Power input (AV_{DD}). When input (PD#) is low while power is applied, the receivers are disabled, the PLL is turned off and the differential clock outputs are tri-stated. When AV_{DD} is grounded, the PLL is turned off and bypassed for test purposes.

When the input frequency is less than the operating frequency of the PLL, approximately 20MHz, the device will enter a low power mode. An input frequency detection circuit on the differential inputs, independent from the input buffers, will detect the low frequency condition and perform the same low power features as when the (PD#) input is low. When the input frequency increases to greater than approximately 20 MHz, the PLL will be turned back on, the inputs and outputs will be enabled and PLL will obtain phase lock between the feedback clock pair (FB_INT, FB_INC) and the input clock pair (CLK_INC, CLK_INT).

The PLL to the **ICS95V857** clock driver uses the input clocks (CLK_INC, CLK_INT) and the feedback clocks (FB_INT, FB_INC) provide high-performance, low-skew, low-jitter, output differential clocks (CLKT[0:9], CLKC[0:9]). The **ICS95V857** is also able to track Spread Spectrum Clock (SSC) for reduced EMI.

The **ICS95V857** is characterized for operation from 0°C to 85°C, and will meet JEDEC Standard 82-1 and 82-1A Class A+ for registered DDR clock drivers.



Absolute Maximum Ratings

Supply Voltage (VDD & AVDD)	-0.5V to 4.6V
Logic Inputs	GND -0.5 V to V _{DD} + 0.5 V
Ambient Operating Temperature	0°C to +85°C
Storage Temperature	-65°C to +150°C

Stresses above those listed under *Absolute Maximum Ratings* may cause permanent damage to the device. These ratings are stress specifications only and functional operation of the device at these or any other conditions above those listed in the operational sections of the specifications is not implied. Exposure to absolute maximum rating conditions for extended periods may affect product reliability.

Electrical Characteristics - Input/Supply/Common Output Parameters

T_A = 0 - 85°C; Supply Voltage A_{VDD}, V_{DD} = 2.5V ± 0.2V

PARAMETER	SYMBOL	CONDITIONS	MIN	TYP	MAX	UNITS
Input High Current	I _{IH}	V _I = V _{DD} or GND	5			μA
Input Low Current	I _{IL}	V _I = V _{DD} or GND			5	μA
Operating Supply Current	I _{DD2.5}	C _L = 0pf @ 200MHz		148	170	mA
	I _{DDPD}	C _L = 0pf			100	μA
Output High Current	I _{OH}	V _{DD} = 2.3V, V _{OUT} = 1V	-18	-32		mA
Output Low Current	I _{OL}	V _{DD} = 2.3V, V _{OUT} = 1.2V	26	35		mA
High Impedance Output Current	I _{OZ}	V _{DD} =2.7V, V _{out} =V _{DD} or GND			±10	mA
Input Clamp Voltage	V _{IK}	V _{DDQ} = 2.3V I _{in} = -18mA			-1.2	V
High-level output voltage	V _{OH}	V _{DD} = min to max, I _{OH} = -1 mA	V _{DDQ} - 0.1			V
		V _{DDQ} = 2.3V, I _{OH} = -12 mA	1.7			V
Low-level output voltage	V _{OL}	V _{DD} = min to max I _{OL} =1 mA			0.1	V
		V _{DDQ} = 2.3V I _{OH} =12 mA			0.6	V
Input Capacitance ¹	C _{IN}	V _I = GND or V _{DD}		3		pF
Output Capacitance ¹	C _{OUT}	V _{OUT} = GND or V _{DD}		3		pF

¹Guaranteed by design at 220MHz, not 100% tested in production.



Recommended Operating Condition (see note 1)

T_A = 0 - 85°C; Supply Voltage AVDD, VDD = 2.5 V +/- 0.2V (unless otherwise stated)

PARAMETER	SYMBOL	CONDITIONS	MIN	TYP	MAX	UNITS
Supply Voltage	V _{DD} , A _{VDD}		2.3	2.5	2.7	V
Low level input voltage	V _{IL}	CLKT, CLKC, FB_INC		0.4	V _{DD} /2 - 0.18	V
		PD#	-0.3		0.7	V
High level input voltage	V _{IH}	CLKT, CLKC, FB_INC	V _{DD} /2 + 0.18	2.1		V
		PD#	1.7		V _{DD} + 0.6	V
DC input signal voltage (note 2)	V _{IN}		-0.3		V _{DD} + 0.3	V
Differential input signal voltage (note 3)	V _{ID}	DC - CLKT, FB_INT	0.36		V _{DD} + 0.6	V
		AC - CLKT, FB_INT	0.7		V _{DD} + 0.6	V
Output differential cross-voltage (note 4)	V _{OX}		V _{DD} /2 - 0.15		V _{DD} /2 + 0.15	V
Input differential cross-voltage (note 4)	V _{IX}		V _{DD} /2 - 0.2	V _{DD} /2	V _{DD} /2 + 0.2	V
High level output current	I _{OH}				-6.4	mA
Low level output current	I _{OL}				5.5	mA
Operating free-air temperature	T _A		0		85	°C

Notes:

1. Unused inputs must be held high or low to prevent them from floating.
2. DC input signal voltage specifies the allowable DC execution of differential input.
3. Differential inputs signal voltages specifies the differential voltage [VTR-VCP] required for switching, where VT is the true input level and VCP is the complementary input level.
4. Differential cross-point voltage is expected to track variations of V_{DD} and is the voltage at which the differential signal must be crossing.



Timing Requirements

$T_A = 0 - 85^\circ\text{C}$; Supply Voltage A_{VDD} , $V_{DD} = 2.5\text{ V} \pm 0.2\text{V}$ (unless otherwise stated)

PARAMETER	SYMBOL	CONDITIONS	MIN	MAX	UNITS
Max clock frequency	freq_{op}	$2.5\text{V} \pm 0.2\text{V} @ 25^\circ\text{C}$	45	233	MHz
Application Frequency Range	freq_{App}	$2.5\text{V} \pm 0.2\text{V} @ 25^\circ\text{C}$	95	220	MHz
Input clock duty cycle	d_{tin}		40	60	%
CLK stabilization	T_{STAB}			15	μs

Switching Characteristics (see note 3)

PARAMETER	SYMBOL	CONDITION	MIN	TYP	MAX	UNITS
Low-to high level propagation delay time	t_{PLH}^1	CLK_IN to any output		3.5		ns
High-to low level propagation delay time	t_{PLL}^1	CLK_IN to any output		3.5		ns
Output enable time	t_{EN}	PD# to any output		3		ns
Output disable time	t_{dis}	PD# to any output		3		ns
Period jitter	$T_{\text{jit (per)}}$	100MHz to 200MHz	-30		30	ps
Half-period jitter	$t(\text{jit_hper})$	100MHz to 200MHz	-75		75	ps
Input clock slew rate	$t_{\text{sl(i)}}$		1		4	V/ns
Output clock slew rate	$t_{\text{sl(o)}}$		1		2	V/ns
Cycle to Cycle Jitter ¹	$T_{\text{cyc}} - T_{\text{cyc}}$	100MHz to 200MHz	-50		50	ps
Static Phase Offset	$t_{\text{(static phase offset)}}^4$		-50	0	50	ps
Output to Output Skew	T_{skew}				40	ps

Notes:

1. Refers to transition on noninverting output in PLL bypass mode.
2. While the pulse skew is almost constant over frequency, the duty cycle error increases at higher frequencies. This is due to the formula: $\text{duty cycle} = t_{\text{wH}}/t_{\text{c}}$, where the cycle (t_{c}) decreases as the frequency goes up.
3. Switching characteristics guaranteed for application frequency range.
4. Static phase offset shifted by design.



Parameter Measurement Information

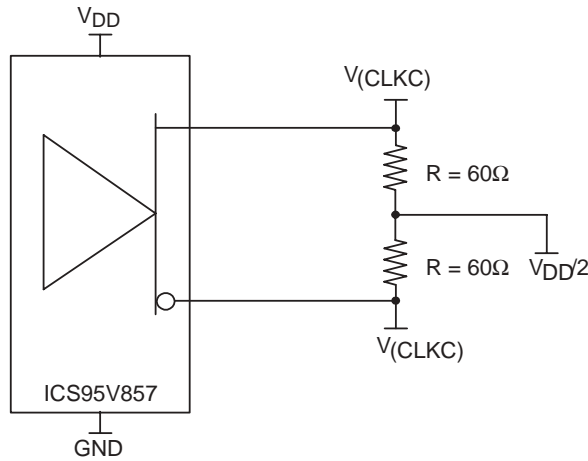

Figure 1. IBIS Model Output Load

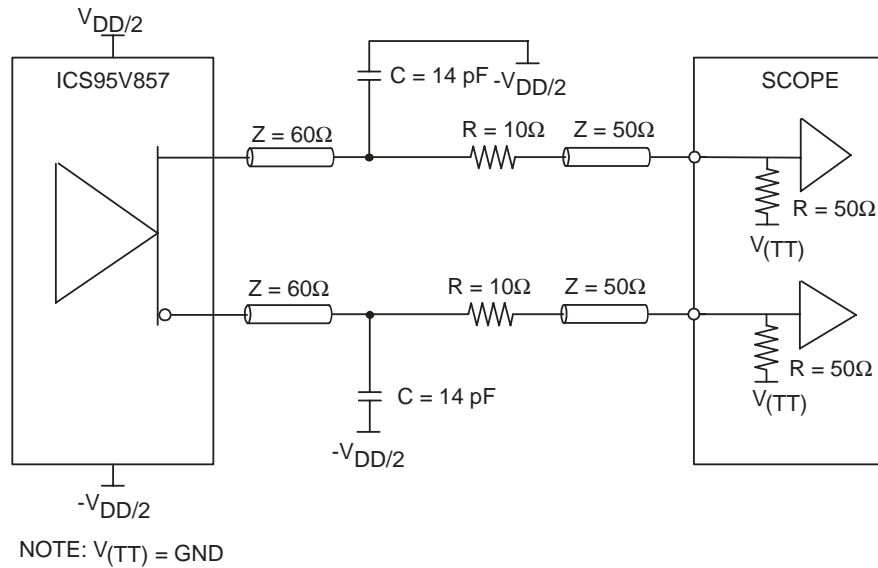

Figure 2. Output Load Test Circuit

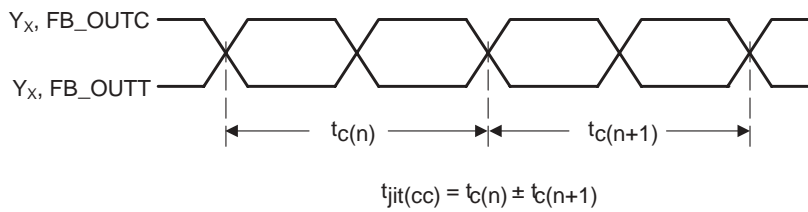

Figure 3. Cycle-to-Cycle Jitter



Parameter Measurement Information

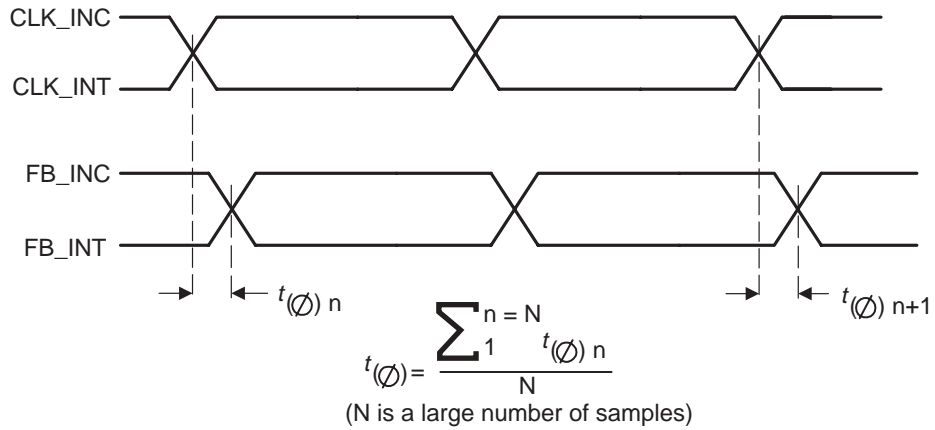

Figure 4. Static Phase Offset

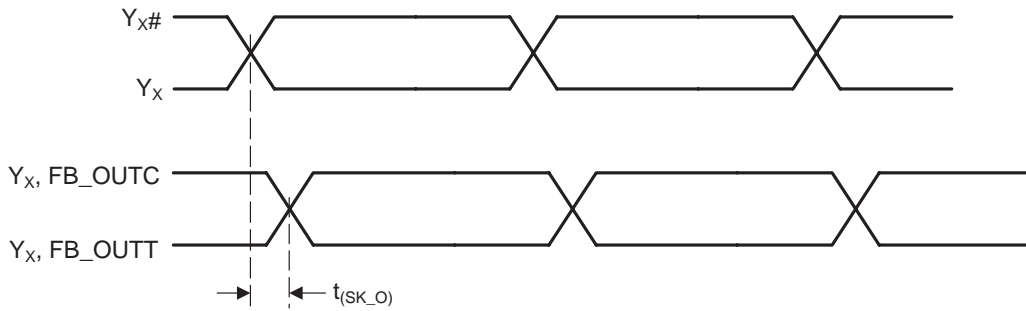

Figure 5. Output Skew

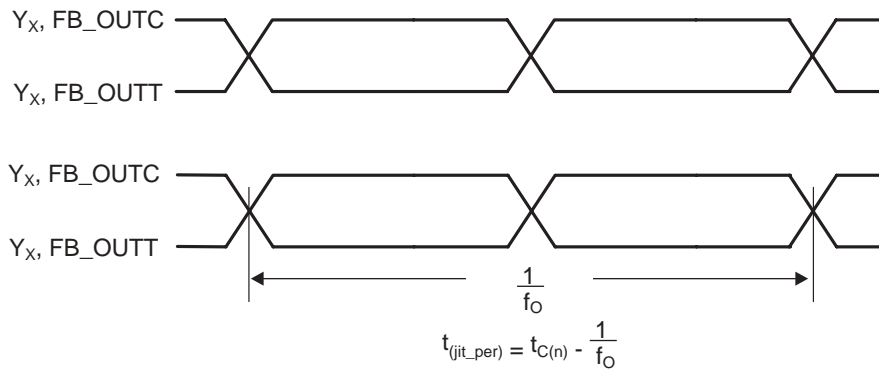

Figure 6. Period Jitter



Parameter Measurement Information

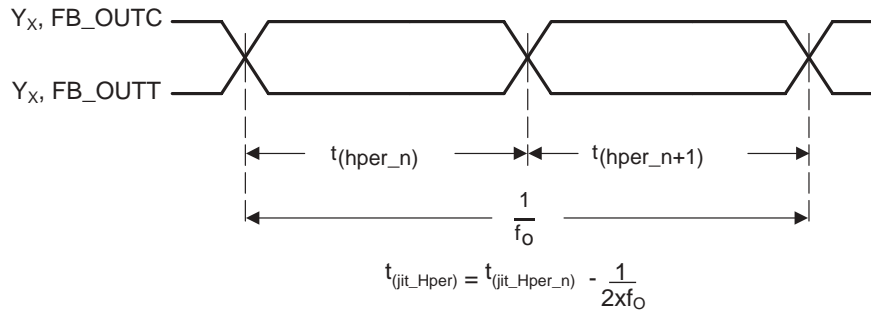

Figure 7. Half-Period Jitter

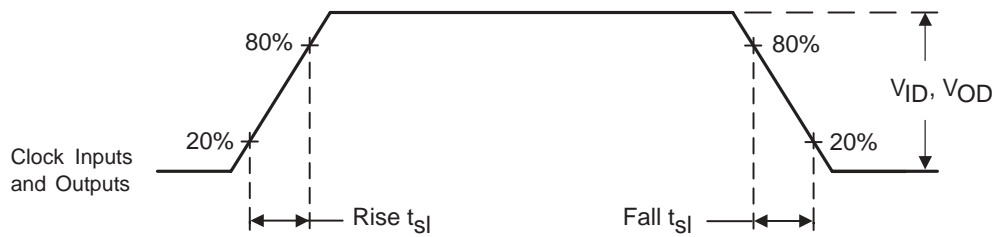
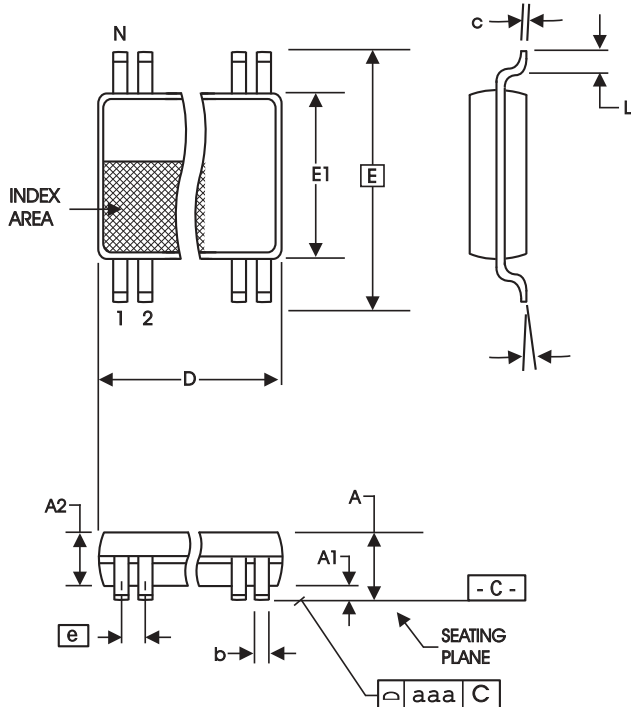

Figure 8. Input and Output Slew Rates



6.10 mm. Body, 0.50 mm. pitch TSSOP
(240 mil) (0.020 mil)

SYMBOL	In Millimeters		In Inches	
	COMMON DIMENSIONS	COMMON DIMENSIONS	COMMON DIMENSIONS	COMMON DIMENSIONS
	MIN	MAX	MIN	MAX
A	--	1.20	--	.047
A1	0.05	0.15	.002	.006
A2	0.80	1.05	.032	.041
b	0.17	0.27	.007	.011
c	0.09	0.20	.0035	.008
D	SEE VARIATIONS		SEE VARIATIONS	
E	8.10 BASIC		0.319 BASIC	
E1	6.00	6.20	.236	.244
e	0.50 BASIC		0.020 BASIC	
L	0.45	0.75	.018	.030
N	SEE VARIATIONS		SEE VARIATIONS	
a	0°	8°	0°	8°
aaa	--	0.10	--	.004

VARIATIONS

N	D mm.		D (inch)	
	MIN	MAX	MIN	MAX
48	12.40	12.60	.488	.496

Reference Doc.: JEDEC Publication 95, MO-153

10-0039

Ordering Information

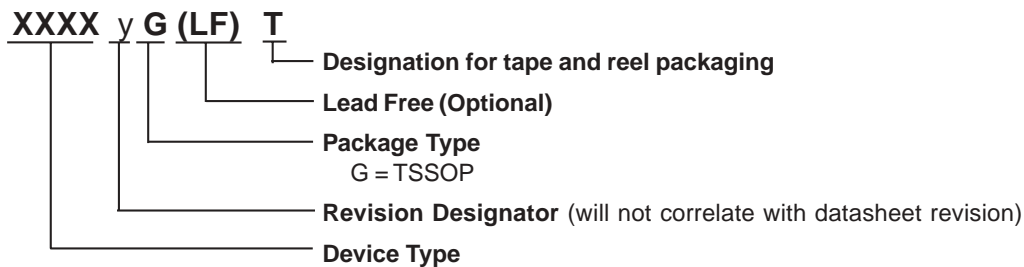

Example:

95V857AGLFT

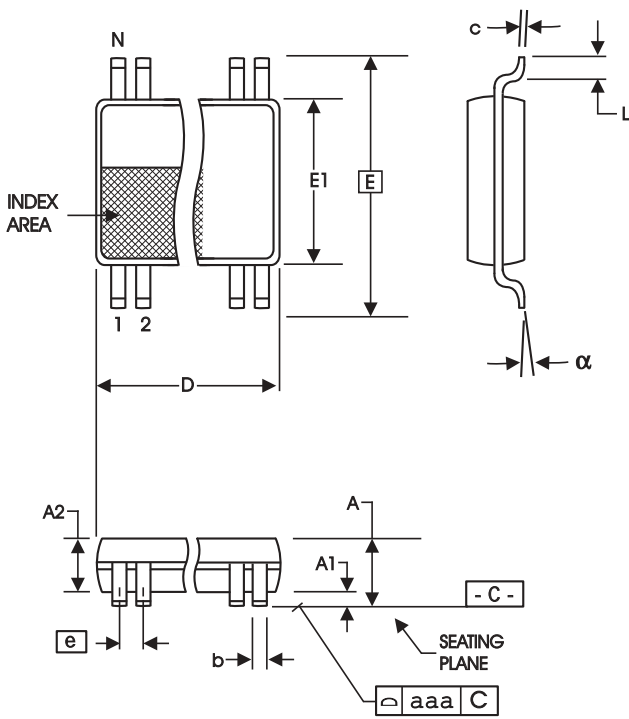

4.40 mm. Body, 0.40 mm. pitch TSSOP
 (173 mil) (16 mil)

SYMBOL	In Millimeters		In Inches	
	COMMON DIMENSIONS	COMMON DIMENSIONS	COMMON DIMENSIONS	COMMON DIMENSIONS
A	--	1.20	--	.047
A1	0.05	0.15	.002	.006
A2	0.80	1.05	.032	.041
b	0.13	0.23	.005	.009
c	0.09	0.20	.0035	.008
D	SEE VARIATIONS		SEE VARIATIONS	
E	6.40 BASIC		0.252 BASIC	
E1	4.30	4.50	.169	.177
e	0.40 BASIC		0.016 BASIC	
L	0.45	0.75	.018	.030
N	SEE VARIATIONS		SEE VARIATIONS	
a	0°	8°	0°	8°
aaa	--	0.08	--	.003

VARIATIONS

N	D mm.		D (inch)	
	MIN	MAX	MIN	MAX
48	9.60	9.80	.378	.386

Reference Doc.: JEDEC Publication 95, MO-153
 10-0037

Ordering Information

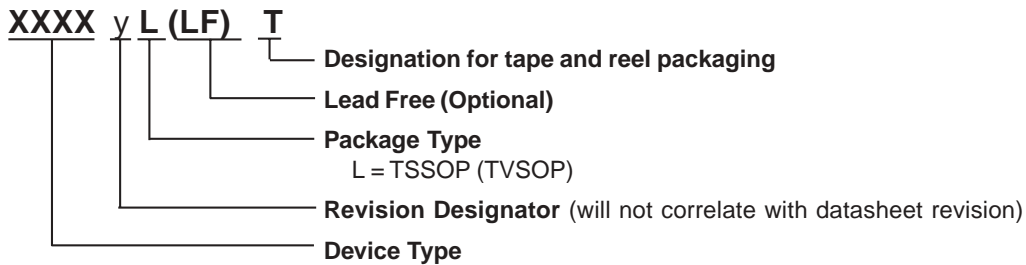

Example:

95V857ALLFT

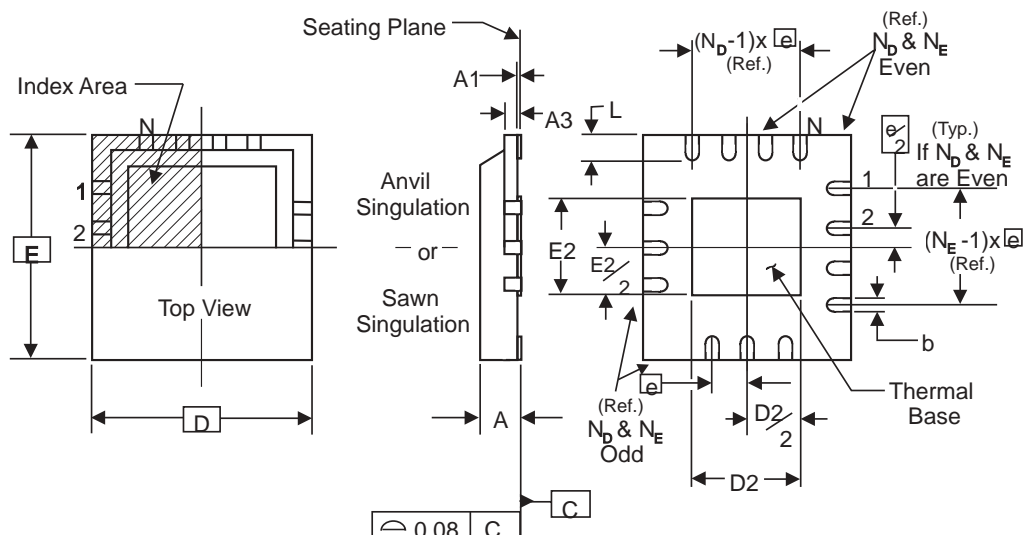

**THERMALLY ENHANCED, VERY THIN, FINE PITCH
QUAD FLAT / NO LEAD PLASTIC PACKAGE**

ALL DIMENSIONS IN MILLIMETERS

		SYMBOL	MIN.	MAX.
N	40			
N_D	10	A	0.80	1.00
N_E	10	A1	0	0.05
D x E BASIC	6.00 x 6.00	A3	0.25 Reference	
D2 MIN. / MAX.	2.75 / 3.05	b	0.18	0.30
E2 MIN. / MAX.	2.75 / 3.05	e	0.50 BASIC	
L MIN. / MAX.	0.30 / 0.50			

Source Reference: MLF2™SE
10-0053

Ordering Information

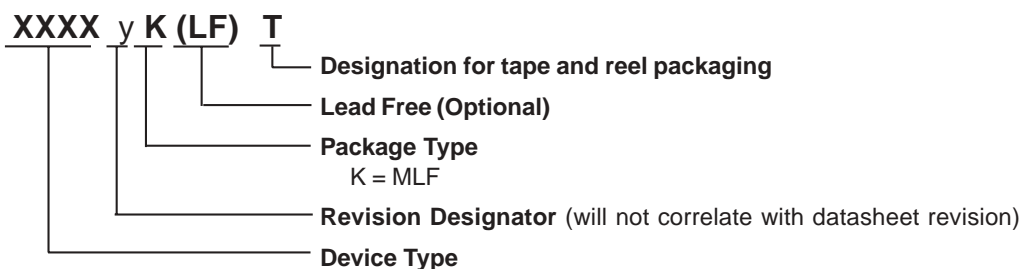

Example:

95V857AKLFT

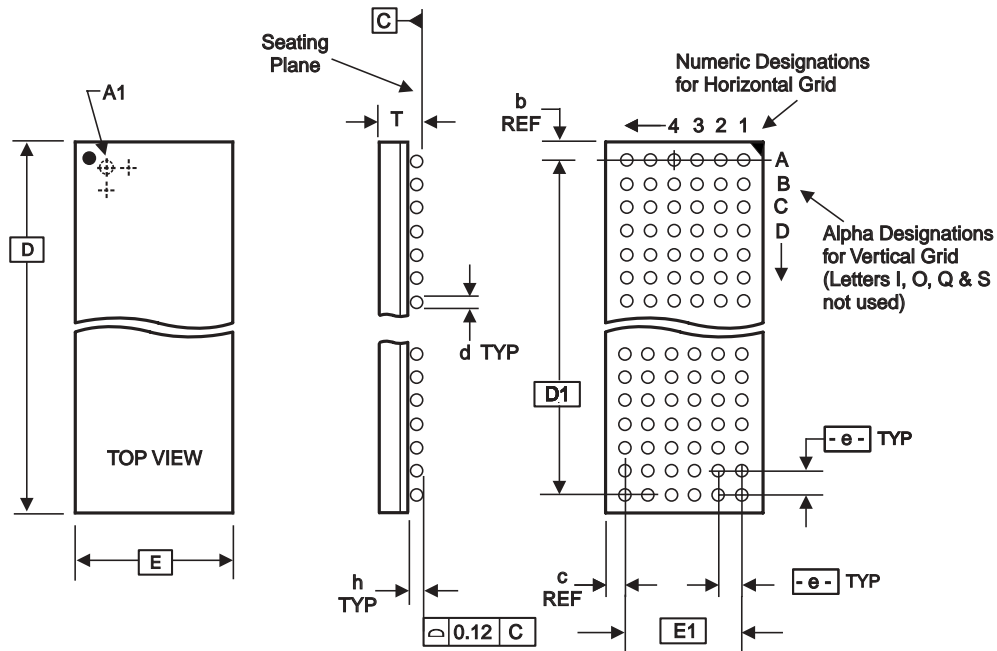

ALL DIMENSIONS IN MILLIMETERS

D	E	T Min/Max	e	BALL GRID		Max. TOTAL	d Min/Max	h Min/Max	D1	E1	REF. DIMENSIONS	
				HORIZ	VERT						b	c
7.00 Bsc	4.50 Bsc	0.86/1.00	0.65 Bsc	6	10	60	0.35/0.45	0.15/0.21	5.85 Bsc	3.25 Bsc	0.575	0.625**

Note: Ball grid total indicates maximum ball count for package. Lesser quantity may be used.

* Source Ref.: JEDEC Publication 95, MO-205*, MO-225**

10-0055

Ordering Information

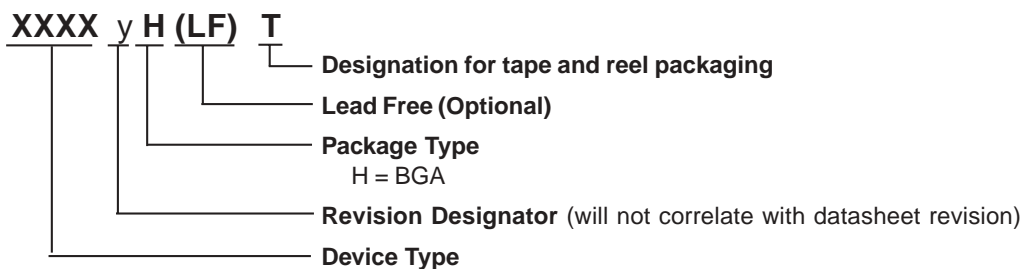

Example:

95V857AHLFT

0674U—01/27/09