

阅读申明

- 1.本站收集的数据手册和产品资料都来自互联网，版权归原作者所有。如读者和版权方有任何异议请及时告之，我们将妥善解决。
- 2.本站提供的中文数据手册是英文数据手册的中文翻译，其目的是协助用户阅读，该译文无法自动跟随原稿更新，同时也可能存在翻译上的不当。建议读者以英文原稿为参考以便获得更精准的信息。
- 3.本站提供的产品资料，来自厂商的技术支持或者使用者的心得体会等，其内容可能存在描述上的差异，建议读者做出适当判断。
- 4.如需与我们联系，请发邮件到marketing@iczoom.com，主题请标有“数据手册”字样。

Read Statement

1. The datasheets and other product information on the site are all from network reference or other public materials, and the copyright belongs to the original author and original published source. If readers and copyright owners have any objections, please contact us and we will deal with it in a timely manner.
2. The Chinese datasheets provided on the website is a Chinese translation of the English datasheets. Its purpose is for reader's learning exchange only and do not involve commercial purposes. The translation cannot be automatically updated with the original manuscript, and there may also be improper translations. Readers are advised to use the English manuscript as a reference for more accurate information.
3. All product information provided on the website refer to solutions from manufacturers' technical support or users the contents may have differences in description, and readers are advised to take the original article as the standard.
4. If you have any questions, please contact us at marketing@iczoom.com and mark the subject with "Datasheets" .

DUAL LVCMOS/LVTTL-TO-DIFFERENTIAL 2.5V, 3.3V, 5V LVPECL MULTIPLEXER

ICS853052

GENERAL DESCRIPTION



The ICS853052 is a Dual LVCMOS / LVTTL-to-Differential 2.5V, 3.3V, 5V LVPECL Multiplexer and a member of the HiPerClocks™ family of High Performance Clocks Solutions from IDT. The ICS853052 has two selectable single ended clock inputs. The single ended clock input accepts LVCMOS or LVTTL input levels and translates them to 2.5V, 3.3V or 5V LVPECL levels. The small outline 8-pin TSSOP or 8-pin SOIC packages make this device ideal for applications where space, high performance and low power are important.

FEATURES

- One differential 2.5V, 3.3V or 5V LVPECL output
- Two selectable LVCMOS/LVTTL clock inputs
- Output frequency: TBD
- Additive phase jitter, RMS: 0.06ps (typical)
- Propagation Delay: 370ps (typical)
- 2.5V, 3.3V or 5V operating supply voltage (operating range 2.375V to 5.5V)
- -40°C to 85°C ambient operating temperature
- Available in both standard (RoHS 5) and lead-free (RoHS 6) packages

BLOCK DIAGRAM

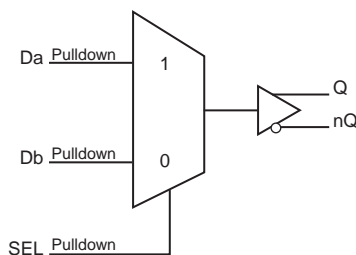

PIN ASSIGNMENT

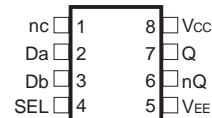

ICS853052

8-Lead TSSOP, 118 mil
3mm x 3mm x 0.95mm package body
G Package
Top View

8-Lead SOIC, 150 mil
3.90mm x 4.90mm x 1.37mm package body
M Package
Top View

The Preliminary Information presented herein represents a product in pre-production. The noted characteristics are based on initial product characterization and/or qualification. Integrated Device Technology, Incorporated (IDT) reserves the right to change any circuitry or specifications without notice.

TABLE 1. PIN DESCRIPTIONS

Number	Name	Type		Description
1	nc	Unused		No connect.
2, 3	Da, Db	Input	Pulldown	LVCMOS / LVTTL clock inputs.
4	SEL	Input	Pulldown	Select input pin. When HIGH, selects Da input clock. When Low selects Db input clock. Single-ended 100H LVPECL interface levels.
5	V _{EE}	Power		Negative supply pin.
6, 7	nQ, Q	Output		Differential output pair. LVPECL interface levels.
8	V _{CC}	Power		Positive supply pin.

NOTE: *Pulldown* refers to internal input resistors. See Table 2, Pin Characteristics, for typical values.

TABLE 2. PIN CHARACTERISTICS

Symbol	Parameter	Test Conditions	Minimum	Typical	Maximum	Units
C _{IN}	Input Capacitance			1		pF
R _{PULLDOWN}	Input Pulldown Resistor			75		kΩ

TABLE 3. CONTROL INPUT FUNCTION TABLE

Inputs	
SEL	Selected Source
0	Db
1	Da

ABSOLUTE MAXIMUM RATINGS

Supply Voltage, V_{CC}	6V (LVPECL mode, $V_{EE} = 0$)
Negative Supply Voltage, V_{EE}	-6V (ECL mode, $V_{CC} = 0$)
Inputs, V_I (LVPECL mode)	-0.5V to $V_{CC} + 0.5$ V
Inputs, V_I (ECL mode)	0.5V to $V_{EE} - 0.5$ V
Outputs, I_O	
Continuous Current	50mA
Surge Current	100mA
Operating Temperature Range, T_A	-40°C to +85°C
Storage Temperature, T_{STG}	-65°C to 150°C
Package Thermal Impedance, θ_{JA}	101.7°C/W (0 m/s) TSSOP 112.7°C/W (0 lfp) SOIC

NOTE: Stresses beyond those listed under Absolute Maximum Ratings may cause permanent damage to the device. These ratings are stress specifications only. Functional operation of product at these conditions or any conditions beyond those listed in the *DC Characteristics* or *AC Characteristics* is not implied. Exposure to absolute maximum rating conditions for extended periods may affect product reliability.

TABLE 4A. DC CHARACTERISTICS, $V_{CC} = 2.5$ V; $V_{EE} = 0$ V

Symbol	Parameter	-40°C			25°C			85°C			Units
		Min	Typ	Max	Min	Typ	Max	Min	Typ	Max	
I_{EE}	Power Supply Current		21			21			21		mA
V_{OH}	Output High Voltage; NOTE 1	1.375	1.475	1.58	1.425	1.495	1.57	1.495	1.53	1.565	V
V_{OL}	Output Low Voltage; NOTE 1	0.605	0.745	0.88	0.625	0.72	0.815	0.64	0.735	0.83	V
V_{IH}	Input High Voltage, Single-Ended	1.275		1.56	1.275		1.56	1.275		-0.83	V
V_{IL}	Input Low Voltage, Single-Ended	0.63		0.965	0.63		0.965	0.63		0.965	V
I_{IH}	Input High Current			200			200			200	μA
I_{IL}	Input Low Current	200			200			200			μA

Input and output parameters vary 1:1 with V_{CC} .

NOTE 1: Outputs terminated with 50Ω to $V_{CC} - 2$ V.

TABLE 4B. DC CHARACTERISTICS, $V_{CC} = 3.3$ V; $V_{EE} = 0$ V

Symbol	Parameter	-40°C			25°C			85°C			Units
		Min	Typ	Max	Min	Typ	Max	Min	Typ	Max	
I_{EE}	Power Supply Current		21			21			21		mA
V_{OH}	Output High Voltage; NOTE 1	2175	2275	2380	2225	2295	2370	2295	2330	2365	mV
V_{OL}	Output Low Voltage; NOTE 1	1405	1545	1680	1425	1520	1615	1440	1535	1630	mV
V_{IH}	Input High Voltage, Single-Ended	2075		2420	2075		2420	2075		2420	mV
V_{IL}	Input Low Voltage, Single-Ended	1355		1675	1355		1675	1355		1675	mV
I_{IH}	Input High Current			200			200			200	μA
I_{IL}	Input Low Current	200			200			200			μA

Input and output parameters vary 1:1 with V_{CC} .

NOTE 1: Outputs terminated with 50Ω to $V_{CC} - 2$ V.

TABLE 4C. DC CHARACTERISTICS, $V_{CC} = 5V$; $V_{EE} = 0V$

Symbol	Parameter	-40°C			25°C			85°C			Units
		Min	Typ	Max	Min	Typ	Max	Min	Typ	Max	
I_{EE}	Power Supply Current		21			21			21		mA
V_{OH}	Output High Voltage; NOTE 1	3875	3975	4105	4080	3925	3995	4070	3995	4065	mV
V_{OL}	Output Low Voltage; NOTE 1	3105	3245	3380	3125	3220	3315	3140	3235	3330	mV
V_{IH}	Input High Voltage, Single-Ended	3775		4120	3775		4120	3775		4120	mV
V_{IL}	Input Low Voltage, Single-Ended	3055		3375	3055		3375	3055		3375	mV
I_{IH}	Input High Current	200			200			200		200	μA
I_{IL}	Input Low Current			200				200			μA

Input and output parameters vary 1:1 with V_{CC} .

NOTE 1: Outputs terminated with 50Ω to $V_{CC} - 2V$.

TABLE 4D. ECL DC CHARACTERISTICS, $V_{CC} = 0V$; $V_{EE} = -5.5V$ TO $-2.375V$

Symbol	Parameter	-40°C			25°C			85°C			Units
		Min	Typ	Max	Min	Typ	Max	Min	Typ	Max	
I_{EE}	Power Supply Current		21			21			21		mA
V_{OH}	Output High Voltage; NOTE 1	-1125	-1025	-920	-1075	-1005	-930	-1005	-970	-935	mV
V_{OL}	Output Low Voltage; NOTE 1	-1895	-1755	-1620	-1875	-1780	-1685	-1860	-1765	-1670	mV
V_{IH}	Input High Voltage, Single-Ended	-1225		-880	-1225		-880	-1225		-880	mV
V_{IL}	Input Low Voltage, Single-Ended	-1945		-1625	-1945		-1625	-1945		-1625	mV
I_{IH}	Input High Current			200			200			200	μA
I_{IL}	Input Low Current	200			200			200			μA

Input and output parameters vary 1:1 with V_{CC} .

NOTE 1: Outputs terminated with 50Ω to $V_{CC} - 2V$.

TABLE 5. AC CHARACTERISTICS, $V_{CC} = 0V$; $V_{EE} = -5.5V$ TO $-2.375V$ OR $V_{CC} = 2.375V$ TO $5.5V$; $V_{EE} = 0V$

Symbol	Parameter	-40°C			25°C			85°C			Units
		Min	Typ	Max	Min	Typ	Max	Min	Typ	Max	
f_{MAX}	Output Frequency		TBD			TBD			TBD		GHz
t_{PLH}	Propagation Delay, Low to High; NOTE 1		TBD			370			TBD		ps
t_{PHL}	Propagation Delay, High to Low; NOTE 1		TBD			370			TBD		ps
f_{jit}	Buffer Additive Phase Jitter, RMS; refer to Additive Phase Jitter section		TBD			0.06			TBD		ps
V_{PP}	Input Voltage Swing (Differential)		TBD			TBD			TBD		ps
t_R/t_F	Output Rise/Fall Time	20% to 80%	TBD			180			TBD		ps

All parameters are measured $\leq 1GHz$ unless otherwise noted.

NOTE 1: Measured from $V_{CC}/2$ of the input crossing point to the differential output crossing point.

ADDITIVE PHASE JITTER

The spectral purity in a band at a specific offset from the fundamental compared to the power of the fundamental is called the ***dBc Phase Noise***. This value is normally expressed using a Phase noise plot and is most often the specified plot in many applications. Phase noise is defined as the ratio of the noise power present in a 1Hz band at a specified offset from the fundamental frequency to the power value of the fundamental. This ratio is expressed in decibels (dBm) or a ratio of the power in the 1Hz

band to the power in the fundamental. When the required offset is specified, the phase noise is called a ***dBc*** value, which simply means dBm at a specified offset from the fundamental. By investigating jitter in the frequency domain, we get a better understanding of its effects on the desired application over the entire time record of the signal. It is mathematically possible to calculate an expected bit error rate given a phase noise plot.

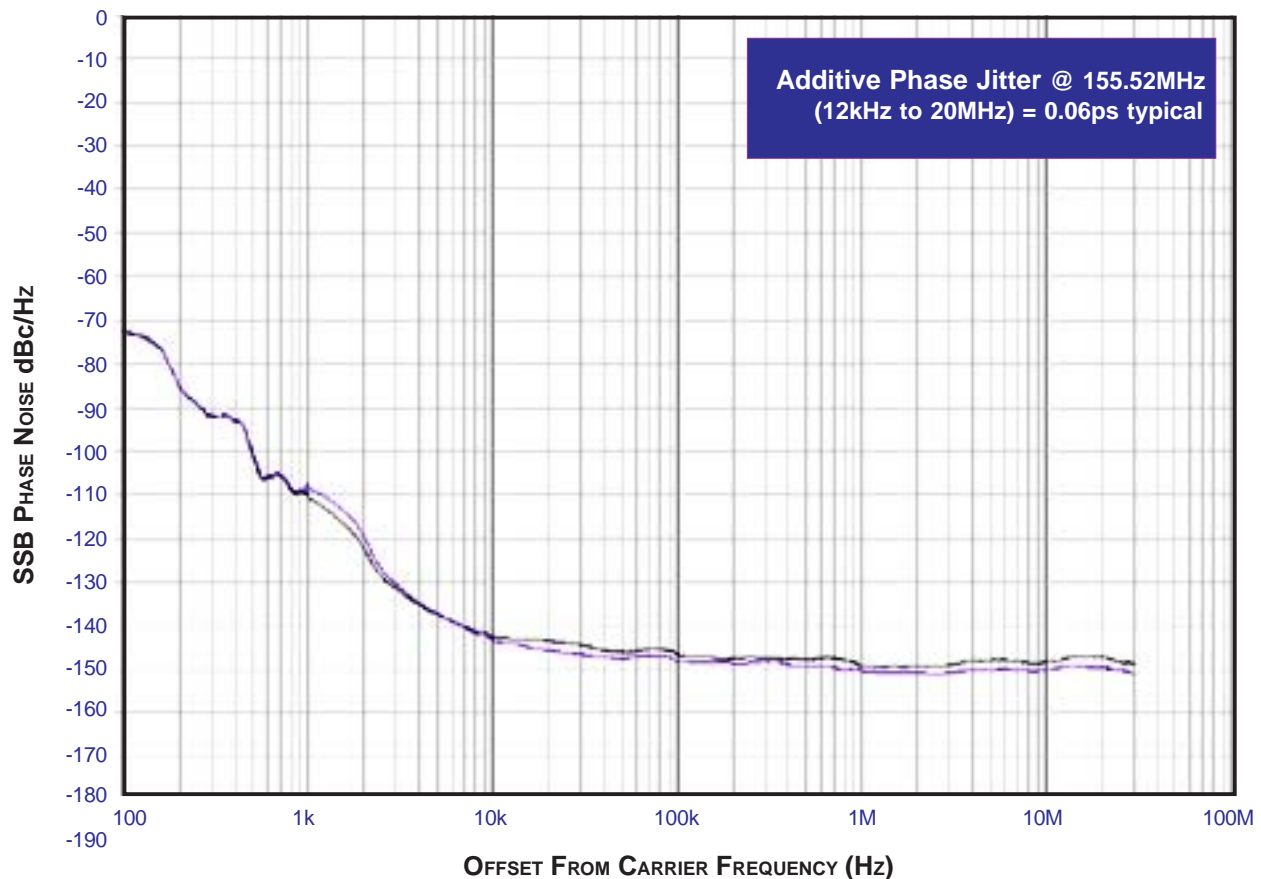

As with most timing specifications, phase noise measurements have issues. The primary issue relates to the limitations of the equipment. Often the noise floor of the equipment is higher than the noise floor of the device. This is illustrated above. The device

meets the noise floor of what is shown, but can actually be lower. The phase noise is dependant on the input source and measurement equipment.

PARAMETER MEASUREMENT INFORMATION

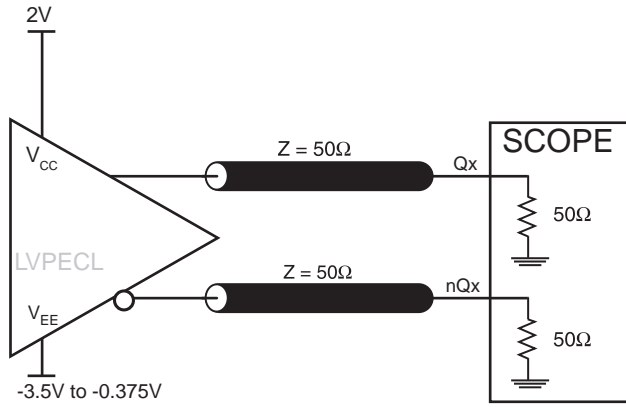

OUTPUT LOAD AC TEST CIRCUIT

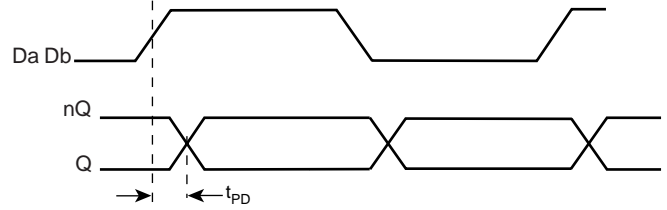

PROPAGATION DELAY

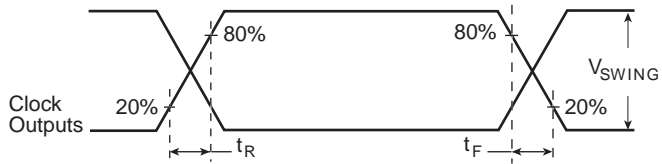

OUTPUT RISE/FALL TIME

TERMINATION FOR 3.3V LVPECL OUTPUTS

The clock layout topology shown below is a typical termination for LVPECL outputs. The two different layouts mentioned are recommended only as guidelines.

FOUT and nFOUT are low impedance follower outputs that generate ECL/LVPECL compatible outputs. Therefore, terminating resistors (DC current path to ground) or current sources must be used for functionality. These outputs are designed to drive 50Ω

transmission lines. Matched impedance techniques should be used to maximize operating frequency and minimize signal distortion. *Figures 2A and 2B* show two different layouts which are recommended only as guidelines. Other suitable clock layouts may exist and it would be recommended that the board designers simulate to guarantee compatibility across all printed circuit and clock component process variations.

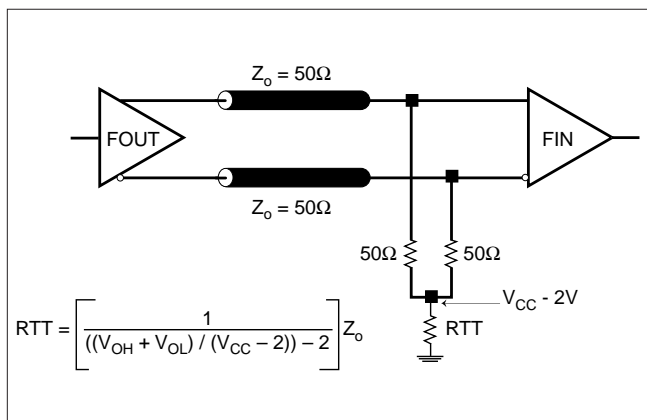

FIGURE 2A. LVPECL OUTPUT TERMINATION

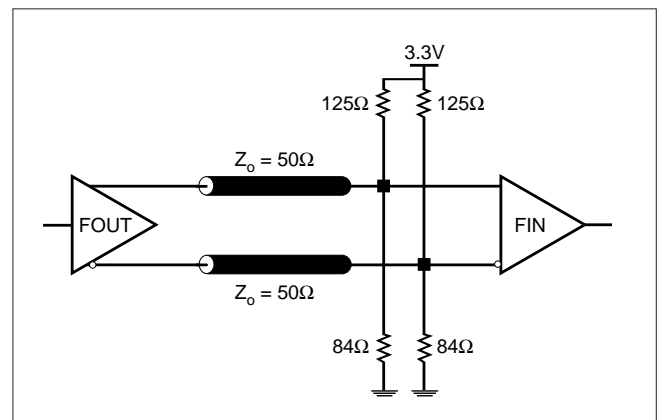

FIGURE 2B. LVPECL OUTPUT TERMINATION

TERMINATION FOR 5V LVPECL OUTPUT

This section shows examples of 5V LVPECL output termination. *Figure 3A* shows standard termination for 5V LVPECL. The termination requires matched load of 50Ω resistors pull down to

$V_{cc} - 2V = 3V$ at the receiver. *Figure 3B* shows Thevenin equivalence of *Figure 3A*. In actual application where the 3V DC power supply is not available, this approach is normally used.

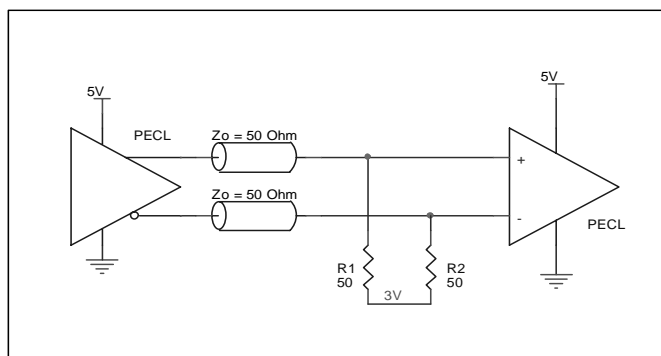

FIGURE 3A. STANDARD 5V LVPECL OUTPUT TERMINATION

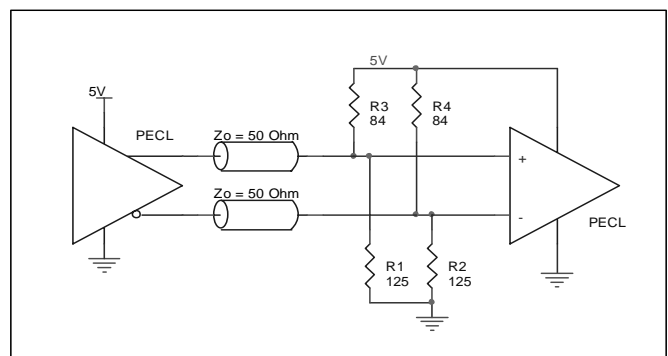

FIGURE 3B. 5V LVPECL OUTPUT TERMINATION EXAMPLE

POWER CONSIDERATIONS

This section provides information on power dissipation and junction temperature for the ICS853052. Equations and example calculations are also provided.

1. Power Dissipation.

The total power dissipation for the ICS853052 is the sum of the core power plus the power dissipated in the load(s). The following is the power dissipation for $V_{CC} = 5.5V$, which gives worst case results.

NOTE: Please refer to Section 3 for details on calculating power dissipated in the load.

- Power (core)_{MAX} = $V_{CC,MAX} * I_{EE,MAX} = 5.5V * 21mA = 115.5mW$
- Power (outputs)_{MAX} = **30.94mW/Loaded Output pair**

2. Junction Temperature.

Junction temperature, T_j , is the temperature at the junction of the bond wire and bond pad and directly affects the reliability of the device. The maximum recommended junction temperature for HiPerClockS™ devices is 125°C.

The equation for T_j is as follows: $T_j = \theta_{JA} * Pd_{total} + T_A$

T_j = Junction Temperature

θ_{JA} = Junction-to-Ambient Thermal Resistance

Pd_{total} = Total Device Power Dissipation (example calculation is in section 1 above)

T_A = Ambient Temperature

In order to calculate junction temperature, the appropriate junction-to-ambient thermal resistance θ_{JA} must be used. Assuming no air flow and a multi-layer board, the appropriate value is 112.7°C/W per Table 6B below.

Therefore, T_j for an ambient temperature of 85°C with all outputs switching is:
 $85^\circ C + 0.146W * 112.7^\circ C/W = 101.52^\circ C$. This is below the limit of 125°C.

This calculation is only an example. T_j will obviously vary depending on the number of loaded outputs, supply voltage, air flow, and the type of board (single layer or multi-layer).

TABLE 6A. THERMAL RESISTANCE θ_{JA} FOR 8-PIN TSSOP, FORCED CONVECTION

θ_{JA} by Velocity (Meters per Second)			
	0	1	2
Multi-Layer PCB, JEDEC Standard Test Boards	101.7°C/W	90.5°C/W	89.8°C/W

TABLE 6B. THERMAL RESISTANCE θ_{JA} FOR 8-PIN SOIC, FORCED CONVECTION

θ_{JA} by Velocity (Linear Feet per Minute)			
	0	200	500
Single-Layer PCB, JEDEC Standard Test Boards	153.3°C/W	128.5°C/W	115.5°C/W
Multi-Layer PCB, JEDEC Standard Test Boards	112.7°C/W	103.3°C/W	97.1°C/W

NOTE: Most modern PCB designs use multi-layered boards. The data in the second row pertains to most designs.

3. Calculations and Equations.

LVPECL output driver circuit and termination are shown in Figure 4.

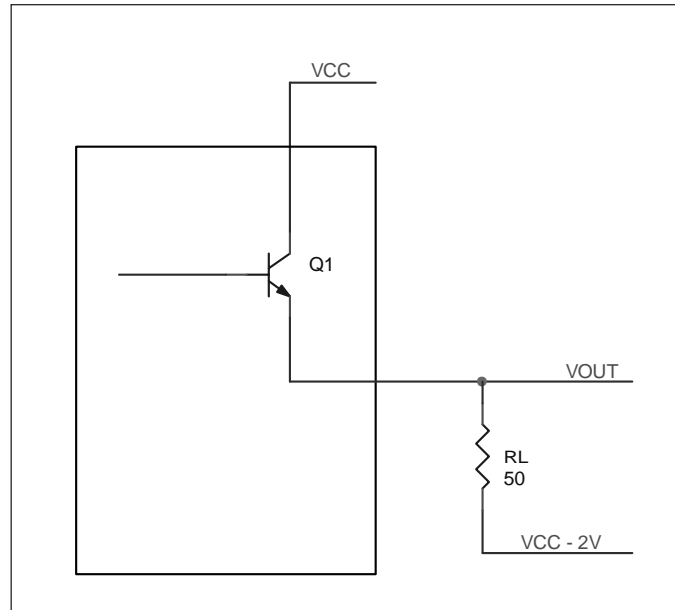

Figure 4. LVPECL Driver Circuit and Termination

To calculate worst case power dissipation into the load, use the following equations which assume a 50Ω load, and a termination voltage of $V_{CC} - 2V$.

- For logic high, $V_{OUT} = V_{OH_MAX} = V_{CC_MAX} - 0.935V$

$$(V_{CC_MAX} - V_{OH_MAX}) = 0.935V$$

- For logic low, $V_{OUT} = V_{OL_MAX} = V_{CC_MAX} - 1.67V$

$$(V_{CC_MAX} - V_{OL_MAX}) = 1.67V$$

$$Pd_H = [(V_{OH_MAX} - (V_{CC_MAX} - 2V))/R_L] * (V_{CC_MAX} - V_{OH_MAX}) = [(2V - (V_{CC_MAX} - V_{OH_MAX}))/R_L] * (V_{CC_MAX} - V_{OH_MAX}) = [(2V - 0.935V)/50\Omega] * 0.935V = 19.92mW$$

$$Pd_L = [(V_{OL_MAX} - (V_{CC_MAX} - 2V))/R_L] * (V_{CC_MAX} - V_{OL_MAX}) = [(2V - (V_{CC_MAX} - V_{OL_MAX}))/R_L] * (V_{CC_MAX} - V_{OL_MAX}) = [(2V - 1.67V)/50\Omega] * 1.67V = 11.02mW$$

$$\text{Total Power Dissipation per output pair} = Pd_H + Pd_L = 30.94mW$$

RELIABILITY INFORMATION

TABLE 7A. θ_{JA} vs. AIR FLOW TABLE FOR 8 LEAD TSSOP

θ_{JA} by Velocity (Meters per Second)			
	0	1	2
Multi-Layer PCB, JEDEC Standard Test Boards	101.7°C/W	90.5°C/W	89.8°C/W

TABLE 7B. θ_{JA} vs. AIR FLOW TABLE FOR 8 LEAD SOIC

θ_{JA} by Velocity (Linear Feet per Minute)			
	0	200	500
Single-Layer PCB, JEDEC Standard Test Boards	153.3°C/W	128.5°C/W	115.5°C/W
Multi-Layer PCB, JEDEC Standard Test Boards	112.7°C/W	103.3°C/W	97.1°C/W

NOTE: Most modern PCB designs use multi-layered boards. The data in the second row pertains to most designs.

TRANSISTOR COUNT

The transistor count for ICS853052 is: 110

Pin compatible with MC100EP58

PACKAGE OUTLINE - G SUFFIX FOR 8 LEAD TSSOP

PACKAGE OUTLINE - M SUFFIX FOR 8 LEAD SOIC

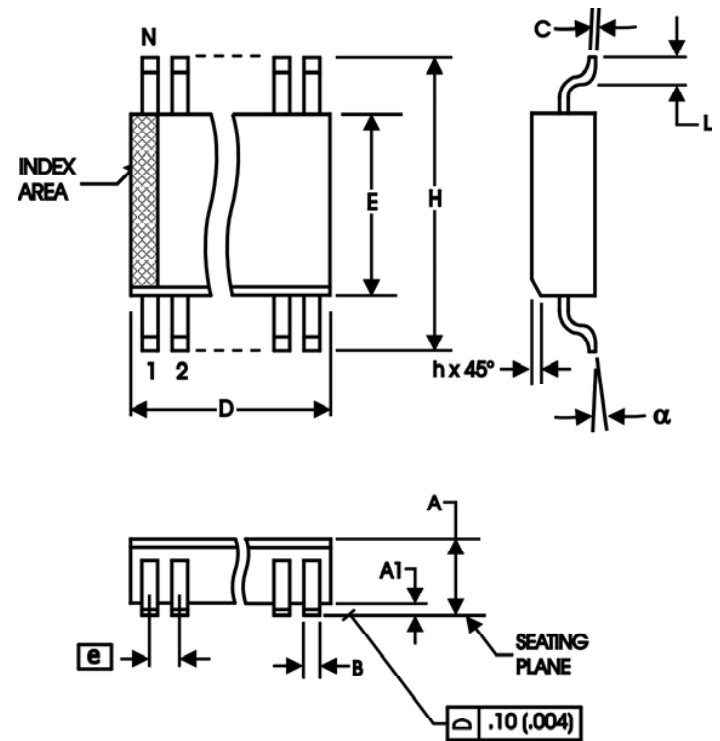
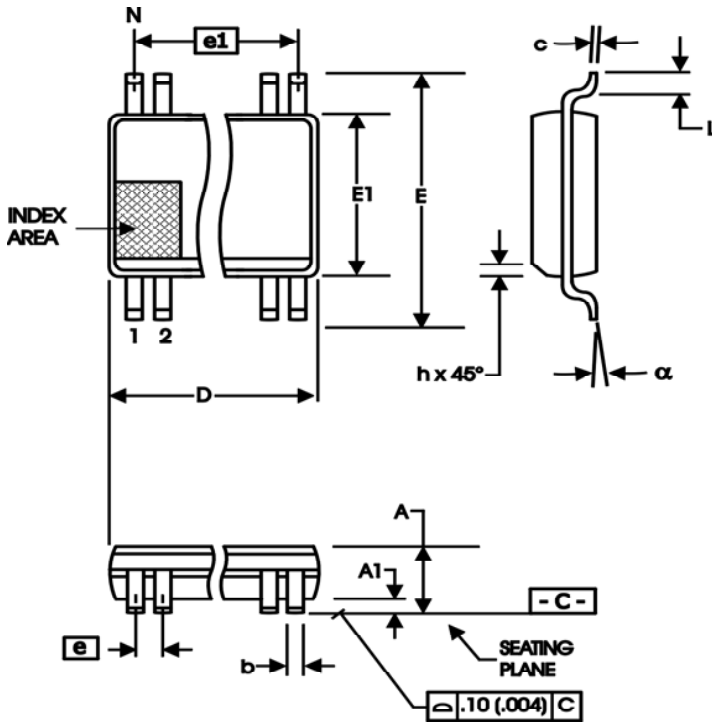

TABLE 8A. PACKAGE DIMENSIONS

SYMBOL	Millimeters	
	Minimum	Maximum
N	8	
A	--	1.10
A1	0	0.15
A2	0.79	0.97
b	0.22	0.38
c	0.08	0.23
D	3.00 BASIC	
E	4.90 BASIC	
E1	3.00 BASIC	
e	0.65 BASIC	
e1	1.95 BASIC	
L	0.40	0.80
α	0°	8°
aaa	--	0.10

Reference Document: JEDEC Publication 95, MO-187

TABLE 8B. PACKAGE DIMENSIONS

SYMBOL	Millimeters	
	MINIMUM	MAXIMUM
N	8	
A	1.35	1.75
A1	0.10	0.25
B	0.33	0.51
C	0.19	0.25
D	4.80	5.00
E	3.80	4.00
e	1.27 BASIC	
H	5.80	6.20
h	0.25	0.50
L	0.40	1.27
α	0°	8°

Reference Document: JEDEC Publication 95, MS-012

TABLE 9. ORDERING INFORMATION

Part/Order Number	Marking	Package	Shipping Packaging	Temperature
ICS853052AG	052A	8 lead TSSOP	tube	-40°C to 85°C
ICS853052AGT	052A	8 lead TSSOP	2500 tape & reel	-40°C to 85°C
ICS853052AGLF	52AL	8 lead "Lead-Free" TSSOP	tube	-40°C to 85°C
ICS853052AGLFT	52AL	8 lead "Lead-Free" TSSOP	2500 tape & reel	-40°C to 85°C
ICS853052AM	853052A	8 lead SOIC	tube	-40°C to 85°C
ICS853052AMT	853052A	8 lead SOIC	2500 tape & reel	-40°C to 85°C
ICS853052AMLF	853052AL	8 lead "Lead-Free" SOIC	tube	-40°C to 85°C
ICS853052AMLFT	853052AL	8 lead "Lead-Free" SOIC	2500 tape & reel	-40°C to 85°C

Parts that are ordered with an "LF" suffix to the part number are the Pb-Free configuration and are RoHS compliant.

While the information presented herein has been checked for both accuracy and reliability, Integrated Device Technology, Incorporated (IDT) assumes no responsibility for either its use or for infringement of any patents or other rights of third parties, which would result from its use. No other circuits, patents, or licenses are implied. This product is intended for use in normal commercial and industrial applications. Any other applications such as those requiring high reliability or other extraordinary environmental requirements are not recommended without additional processing by IDT. IDT reserves the right to change any circuitry or specifications without notice. IDT does not authorize or warrant any IDT product for use in life support devices or critical medical instruments.

Innovate with IDT and accelerate your future networks. Contact:

www.IDT.com

For Sales

800-345-7015
408-284-8200
Fax: 408-284-2775

For Tech Support

netcom@idt.com
480-763-2056

Corporate Headquarters

Integrated Device Technology, Inc.
6024 Silver Creek Valley Road
San Jose, CA 95138
United States
800 345 7015
+408 284 8200 (outside U.S.)

Asia Pacific and Japan

Integrated Device Technology
Singapore (1997) Pte. Ltd.
Reg. No. 199707558G
435 Orchard Road
#20-03 Wisma Atria
Singapore 238877
+65 6 887 5505

Europe

IDT Europe, Limited
321 Kingston Road
Leatherhead, Surrey
KT22 7TU
England
+44 (0) 1372 363 339
Fax: +44 (0) 1372 378851



www.IDT.com