

阅读申明

- 1.本站收集的数据手册和产品资料都来自互联网，版权归原作者所有。如读者和版权方有任何异议请及时告之，我们将妥善解决。
- 2.本站提供的中文数据手册是英文数据手册的中文翻译，其目的是协助用户阅读，该译文无法自动跟随原稿更新，同时也可能存在翻译上的不当。建议读者以英文原稿为参考以便获得更精准的信息。
- 3.本站提供的产品资料，来自厂商的技术支持或者使用者的心得体会等，其内容可能存在描述上的差异，建议读者做出适当判断。
- 4.如需与我们联系，请发邮件到marketing@iczoom.com，主题请标有“数据手册”字样。

Read Statement

1. The datasheets and other product information on the site are all from network reference or other public materials, and the copyright belongs to the original author and original published source. If readers and copyright owners have any objections, please contact us and we will deal with it in a timely manner.
2. The Chinese datasheets provided on the website is a Chinese translation of the English datasheets. Its purpose is for reader's learning exchange only and do not involve commercial purposes. The translation cannot be automatically updated with the original manuscript, and there may also be improper translations. Readers are advised to use the English manuscript as a reference for more accurate information.
3. All product information provided on the website refer to solutions from manufacturers' technical support or users the contents may have differences in description, and readers are advised to take the original article as the standard.
4. If you have any questions, please contact us at marketing@iczoom.com and mark the subject with "Datasheets" .



TDA7427

AM-FM RADIO FREQUENCY SYNTHESIZER AND IF COUNTER

- ON-CHIP REFERENCE OSCILLATOR AND PROGRAMMABLE IF COUNTER
- VHF INPUT AND PRECOUNTER FOR FREQUENCIES UP TO 290MHz (SUITABLE FOR DAB APPLICATION)
- HF INPUT FOR FREQUENCIES UP TO 64MHz (SHORT WAVE BAND)
- IN-LOCK DETECTOR FOR SEARCH/STOP STATION FUNCTION
- STANDBY MODE FOR LOW POWER CONSUMPTION
- HIGH CURRENT SOURCE FOR 0.5ms LOCK-IN TIME
- DIGITAL PORT EXTENSION WITH TWO OUTPUTS FOR FLEXIBILITY IN APPLICATION
- FULLY PROGRAMMABLE BY I²C BUS

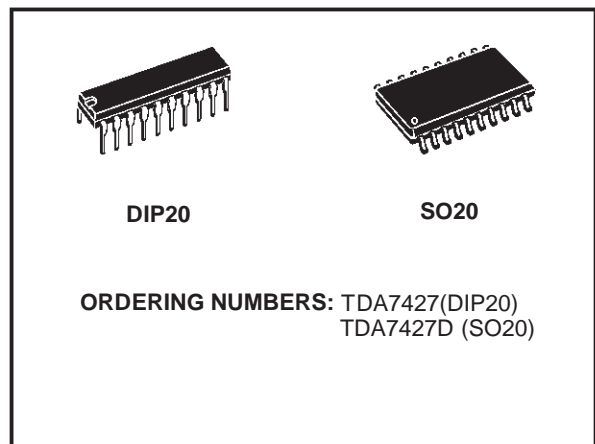

with an additional IF counting system that performs all the functions needed in a complete PLL radio tuning system for conventional and high speed RDS tuners. The device has dedicated outputs for IN-LOCK detection and Search/Stop station.

DESCRIPTION

The TDA7427 is a PLL frequency synthesizer

BLOCK DIAGRAM

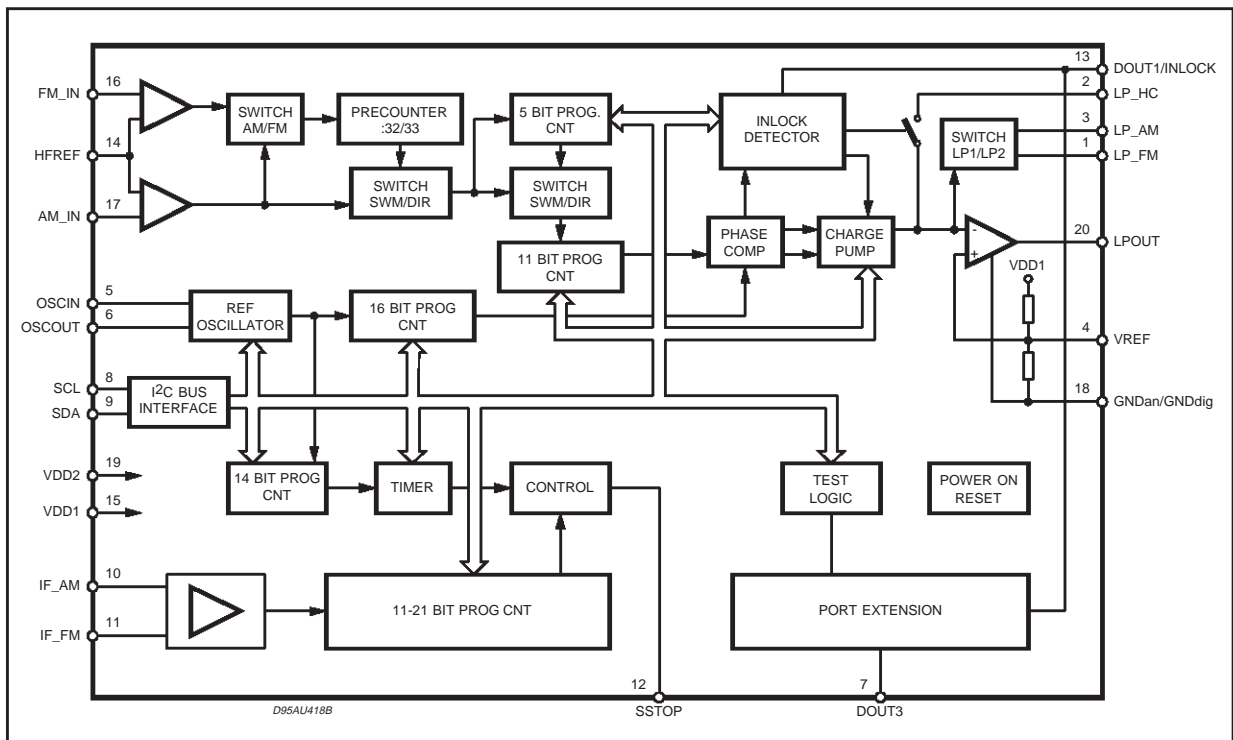

TDA7427

ABSOLUTE MAXIMUM RATINGS

Symbol	Parameter	Value	Unit
V _{DD1}	Supply Voltage	- 0.3 to + 7	V
V _{DD2}	Supply Voltage	- 0.3 to + 11	V
P _{tot}	Total Power Dissipation	300	mW
T _{stg}	Storage Temperature	- 55 to + 150	°C
T _{amb}	Ambient Temperature	-40 to + 85	°C

PIN CONNECTION

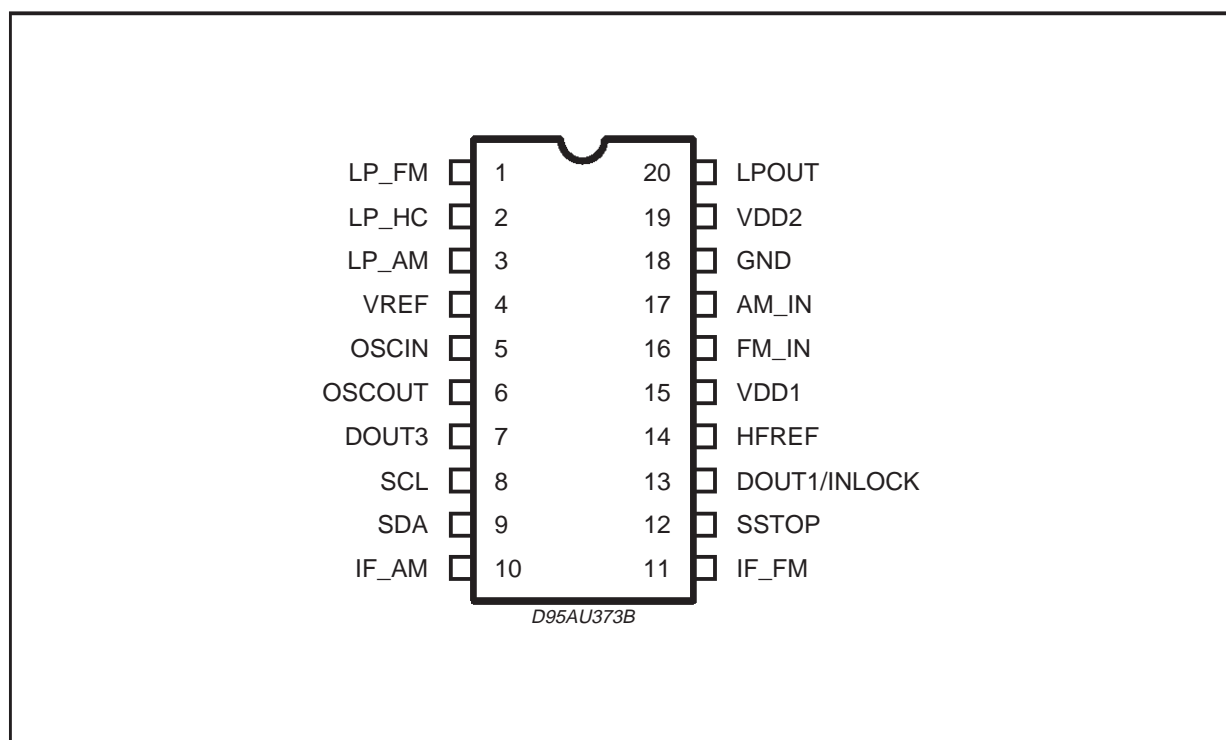

THERMAL DATA

Symbol	Parameter	DIP20	SO20	Unit
R _{th j-amb}	Thermal Resistance Junction-Ambient	max 100	150	°C/W

PIN DESCRIPTION (TDA7427/D)

PIN	SYMBOL	DESCRIPTION	INPUT/OUTPUT
1	LP_FM	Filter OPAMP input, charge pump output (FM mode)	
2	LP_HC	Filter OPAMP input, charge pump output (high current mode)	
3	LP_AM	Filter OPAMP input, charge pump output (AM mode)	
4	VREF	OPAMP reference voltage	
5	OSCIN	Oscillator reference clock input	
6	OSCOU	Oscillator output	
7	DOU3	Open collector output	
8	SCL	I ² C bus clock input	Input
9	SDA	I ² C bus data I/O	Input/output
10	IF_AM	IF counter input (AM mode)	Analog input
11	IF_FM	IF counter input (FM mode)	Analog input
12	SSTOP	IF counter result output	Output
13*	DOU1	Digital output	Push-pull output
13*	INLOCK	Inlock detector output	Output
14	HFREF	HF reference	
15	VDD1	Positive power supply 5V	Supply
16	FM_IN	High frequency input FM	Analog input
17	AM_IN	High frequency input AM	Analog input
18	GND	Analog digital ground	Supply
19	VDD2	Positive power supply 10V	Supply
20	LPOUT	Filter input, charge pump output	

* Pin function is userdefined by software

ELECTRICAL CHARACTERISTICS ($T_{amb} = 25^{\circ}C$; $V_{DD1} = 5V$; $V_{DD2} = 10V$; $f_{osc} = 4MHz$; unless otherwise specified).

Symbol	Parameter	Test Condition	Min.	Typ.	Max.	Unit
V_{DD1}	Supply Voltage		4.5	5.0	5.5	V
V_{DD2}	Supply Voltage			9.0	11.0	V
I_{DD1}	Supply Current	no output load	2	4	6	mA
I_{DD2}	Supply Current	PLL locked	1	2	3	mA
$I_{DD1\ STB}$	Supply Current	Standby mode			1	μA
RF INPUT (AM_IN, FM_IN)						
f_{iAM}	Input Frequency AM	$V_i = 100mV_{rms}$ sinusoidal	0.5		64	MHz
f_{iFM}	Input Frequency FM	$V_i = 100mV_{rms}$ sinusoidal	30		200	MHz
V_{iMIN}	Min Input Voltage AM	0.5 to 16MHz range sinusoidal			30	mVrms
V_{iMAX}	Max Input Voltage AM	0.6 to 16MHz range sinusoidal	600			mVrms
V_{iMIN}	Min Input Voltage FM	70 to 120MHz range sinusoidal			30	mVrms
V_{iMAX}	Max Input Voltage FM	70 to 120MHz range sinusoidal	600			mVrms
Z_{in}	Input Impedance FM input		3	4	5	$K\Omega$
Z_{in}	Input Impedance AM input		3	4	5	$K\Omega$
IF COUNTER (IF_AM, IF_FM)						
f_{iAM}	Input Frequency range AM	$V_i = 100mV_{rms}$	0.400		11	MHz
f_{iAM}	Input Frequency range FM	$V_i = 100mV_{rms}$	10		11	MHz
V_{iMIN}	Min Input Voltage AM IF pin	$f_{in} = 455kHz$			30	mVrms
V_{iMIN}	Min Input Voltage FM IF pin	$f_{in} = 10.7MHz$			30	mVrms
V_{iMAX}	Max Input Voltage AM IF pin	$f_{in} = 455kHz$	600			mVrms
V_{iMAX}	Max Input Voltage FM IF pin	$f_{in} = 10.7MHz$	600			mVrms
Z_{in}	Input Impedance FM IF pin		3	4	5	$K\Omega$
Z_{in}	Input Impedance AM IF pin		3	4	5	$K\Omega$
BUS INTERFACE						
T_j	Noise Suppression Time Constant on SCL, SDA Input			50		ns
f_{SCL}	SCL Clock Frequency				400	kHz
t_{AA}	SCL Low to SDA Data Valid		300			ns
t_{buf}	Time the bus must be free for the new transmission		4.7			μs
$t_{HD-START}$	START Condition hold time		4.0			μs
t_{LOW}	Clock Low Period		4.7			μs
t_{HIGH}	Clock High Period		4.0			μs
t_{SU-SDA}	Start Condition Setup Time		4.7			μs
$t_{HD-DATA}$	Data Input Hold Time				1	μs
$t_{SU-DATA}$	Data Input Setup Time		250			ns
t_R	SDA & SCL Rise Time				1	μs
t_F	SDA & SCL Full Time			0.3		μs
$t_{SU-STOP}$	Stop Condition Setup Time		4.7			μs
t_{DH}	DATA OUT Time		300			ns

ELECTRICAL CHARACTERISTICS (continued)

Symbol	Parameter	Test Condition	Min.	Typ.	Max.	Unit
V _{IL}	Input Low Voltage				1	V
V _{IH}	Input High Voltage		3			V
I _{IN}	Input Current		-5		+5	μA
V _{OUT}	Output Voltage SDA acknowledge	I _O = 1.6mA		0.15	0.4	V
OSCILLATOR						
t _{bu}	Build Up Time	f _{out} = 4MHz			100	ms
C _{in}	Internal Capacitance			20		pF
C _{OUT}	Internal Capacitance	f _{osc} = 4MHz		20		pF
Z _{in}	Input Impedance	f _{osc} = 4MHz			100	KΩ
V _{in}	Input Voltage (for Slave Mode)	f _{IN} = 4 to 13MHz (Sinus) capacitance coupling	300		V _{DD}	mV _{pp}
f _{in}	Max Input frequency (for Slave Mode)	V _{IN} = 600mV _{PP} (Sinus)	30			MHz
LOOP FILTER (LP_FM, LP_AM, LP_HC, LP_OUT)						
I _{IN}	Input Leakage Current (*)	V _{IN} = GND; PD _{out} = Tristate (1)	-1	0.1	1	μA
I _{IN}	Input Leakage Current (*)	V _{IN} = V _{DD1} ; PD _{out} = Tristate (1)	-1	0.1	1	μA
V _{OL}	Output Voltage Low	I _{OUT} = -0.2mA		0	0.5	V
V _{OH}	Output Voltage High	I _{OUT} = 0.2mA	9.5	10		V
I _{OUT}	Output Current Sink		10	30		mA
I _{OUT}	Output Current Source	V _{OUT} = 0.5 to 9.5V	10	30		mA
DOUT1/SSTOP (push-pull outputs)						
V _{OL}	Output Voltage Low	I _{OUT} = -0.1mA		0.1	0.2	V
V _{OH}	Output Voltage High	I _{OUT} = 0.1mA	V _{DD1} *0.2	4.9		V
DOUT3 (open collector output)						
I _{OUT}	Output leakage Current	V _{OUT} = 10V	-1	0.1	1	mA
V _{OL}	Output Voltage Low	I _{OUT} = -1mA		0.2	0.5	V
I _{OUT}	Output Current Sink	V _{OUT} = 0.5 to 9.5V		3	5	mA

1) PD = Phase Detector

(*) LP_FM and LP_HC pins only

GENERAL DESCRIPTION

This circuit contains a frequency synthesiser and a loop filter for use in FM/AM radio tuning systems. Only a VCO is required to build a complete PLL system. For auto search/stop operation an IF counter system is available.

For FM and SW AM application, the counter works in a two-stage configuration. The first stage is a swallow counter with a two modulus (:32/33) precounter. The second stage is an 11-bit programmable counter.

For LW and MW application, a 16-bit programmable counter is available.

The circuit receives the scaling factors for the programmable counters and the values of the reference frequencies via a I²C bus interface.

The reference frequency is generated by an internal XTAL oscillator followed by the reference divider. The device can operate with XTAL oscillator between 4 and 13MHz either in master mode and in slave mode.

The reference and step frequencies are free selectable. (XTAL frequency divided by an integer value). The outputs signals of the phase detector are switching the programmable current sources. The loop filter integrates their currents to a DC voltage.

Values of the current sources are programmable by 6 bits also received via the I²C bus.

To minimize the noise induced by the digital part of the system, a separate power supply supplies the internal loop filter amplifier. The loop gain can be set for different conditions by setting the current values of the charge/pump generator.

IF COUNTER SYSTEM

Two separate inputs are available for AM and FM IF signals. The level of integration is adjustable by six different measuring cycle times.

The tolerance of the accepted count value is adjustable, to reach an optimum compromise for search speed and precision of the evaluation.

For the FM range the center frequency of the measured count value is adjustable in 32 steps, to get the possibility of fitting the IF filter tolerance. In the AM range an IF frequency of 448 to 479KHz (10.684 to 10.715MHz for AM up-conversion) with 1KHz steps is available.

PLL FREQUENCY SYNTHESIZER

Input Amplifiers

The signals applied on AM and FM inputs are amplified to get a logic level in order to drive the frequency dividers.

The typical input impedance for FM and AM inputs is 4kΩ.

Table 1. Address Organization

FUNCTION	SUBAD	MSB							LSB	
		BIT 7	BIT 6	BIT 5	BIT 4	BIT 3	BIT 2	BIT 1	BIT 0	
PLL CHARGE PUMP	00H	LPIN1/2	CURRH	B1	B0	A3	A2	A1	A0	
PLL COUNTER	01H	PC7	PC6	PC5	PC4	PC3	PC2	PC1	PC0	
PLL COUNTER	02H	PC15	PC14	PC13	PC12	PC11	PC10	PC9	PC8	
PLL REF COUNTER	03H	RC7	RC6	RC5	RC4	RC3	RC2	RC1	RC0	
PLL REF COUNTER	04H	RC15	RC14	RC13	RC12	RC11	RC10	RC9	RC8	
PLL LOCK DETECT	05H	LDENA	INLOCK	D3	D2	D1	D0	PM1	PM0	
IFC REF COUNTER	06H	IRC7	IRC6	IRC5	IRC4	IRC3	IRC2	IRC1	IRC0	
IFC REF COUNTER	07H	IFCM1	IFCM0	IRC13	IRC12	IRC11	IRC10	IRC9	IRC8	
IFC CONTROL	08H	IFENA	-	-	-	-	EW2	EW1	EW0	
IFC CONTROL	09H	IFS2	IFS1	IFS0	CF4	CF3	CF2	CF1	CF0	
OSC ADJUST	0AH	-	-	-	OSC4	OSC3	OSC2	OSC1	OSC0	
PORT EXTENSION	0BH	-	-	-	-	-	DOUT3	-	DOUT1	

Figure 1. FM and AM (SW) operation (swallow mode)

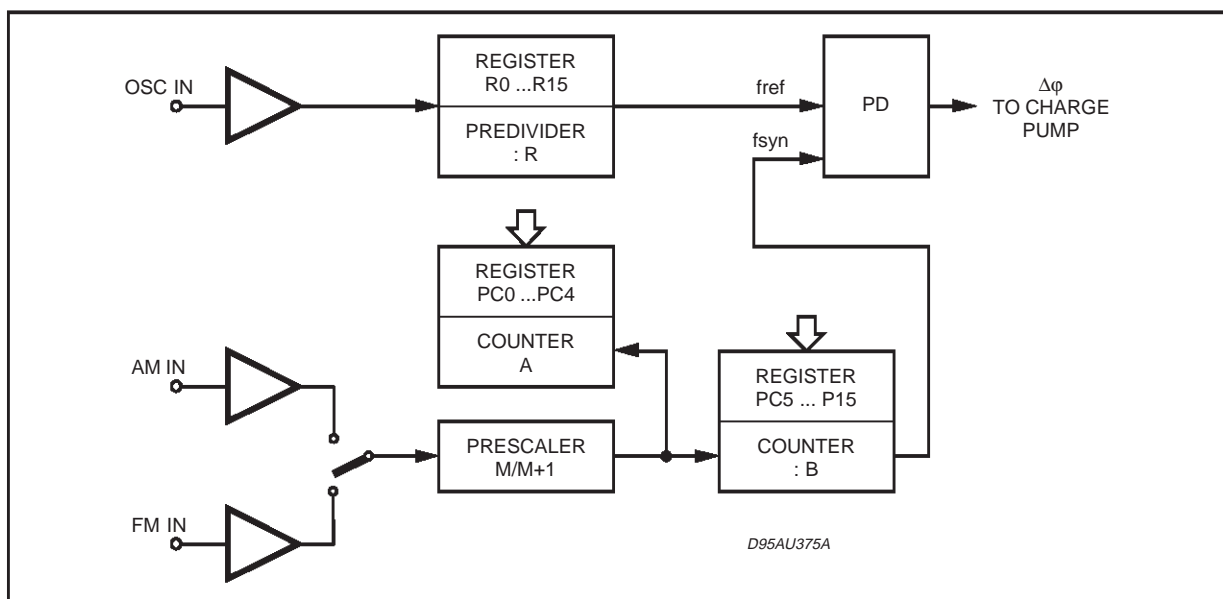
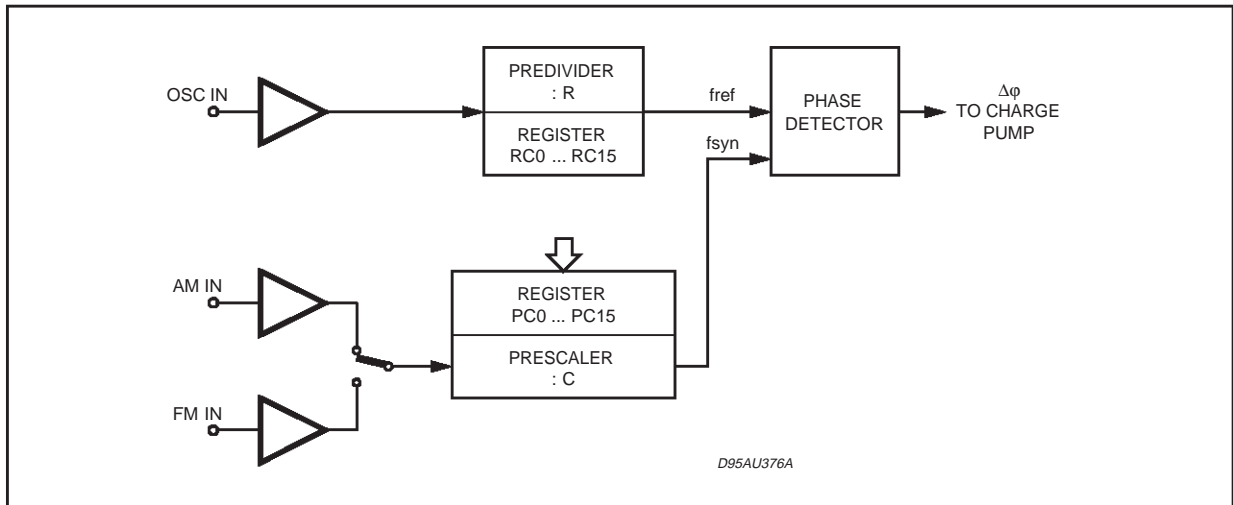

Table 2. Control Register Functions.

REGISTER NAME	FUNCTION
PC	Programmable counter for VCO frequency
RC	Reference counter PLL
IRC	Reference counter IF
IFCM	IF counter mode selector
EW	Frequency error window IF counter
IFENA	Enable IFRC
CF	Center frequency IF counter
IFS	Sampling time IF counter
PM	Stby, FM, AM, AM swallow mode selector
D	Programmable delay and phase error for lock detector
LPIN1/2	Loop filter input select
PLLSTOP	PLL stop
A	Charge pump high current
B	Charge pump low current
LDENA	Lock detector enable
CURRH	Set current high
OSC	Oscillator adjust
DOUT1	Push pull output 5V
DOUT3	Open collector output
INLOCK	Lock detector output

Figure 2. AM direct mode operation for SW, MW and LW



DIVIDER FROM VCO FREQUENCY TO REFERENCE FREQUENCY

This divider provides a low frequency f_{SYN} which phase is compared with the reference frequency f_{REF} . It is controlled by the registers PC0 to PC4 and PC5 to PC15

OPERATING MODES

Four operating modes are available for PLL; they are user programmable with the Mode PM registers (see table):

PM0	PM1	Operating Mode
0	0	Standby
1	0	AM (swallow)
0	1	AM (direct)
1	1	FM

- **Standby mode:** in this mode all device functions are stopped. This allows low current consumption without loss of information in all registers. The pin LP-OUT is forced to 0V, and all data registers are set to EFH. The oscillator keeps running.

- **FM and AM (SW) Swallow Mode (SW):** in this mode the FM or AM signal is applied to a 32/33 prescaler, which is controlled by a 5 bit divider 'A'. The 5 bit register (PC0 to PC4) controls this divider. In parallel the output of the prescaler is connected to a 11 bit divider 'B'. (PC5 to PC15).

$$f_{OSC} = (R+1) \cdot f_{REF}$$

Dividing range calculation :

$$f_{VCO} = [33 \cdot A + (B + 1 - A) \cdot 32] \cdot f_{REF}$$

$$f_{VCO} = (32 \cdot B + A + 32) \cdot f_{REF}$$

Important: for correct operation $A \leq 32$, $B \geq A$, with A and B variable values of the dividers).

- **AM direct mode:** the AM signal is applied directly to the 16 bit static divider 'C'. (PC0 to PC15)

$$f_{OSC} = (R + 1) \cdot f_{REF}$$

Dividing range:

$$f_{VCO} = (C + 1) \cdot f_{REF}$$

THREE STATE PHASE COMPARATOR

The phase comparator generates a phase error signal according to phase difference between f_{SYN} and f_{REF} . This phase error signal drives the charge pump current generator (fig. 3)

CHARGE PUMP CURRENT GENERATOR

This stage generates signed pulses of current. The phase error signal decides the duration and polarity of those pulses.

The current absolute values are programmable by A0, A1, A2 registers for high current and B0, B1, registers for low current.

LOW NOISE CMOS OP-AMP

An internal voltage divider at pin VREF connects the positive input of the low noise Op-Amp. The charge pump output connects the negative input. This internal amplifier in cooperation with external components can provide an active filter.

Figure 3. Phase comparator waveforms

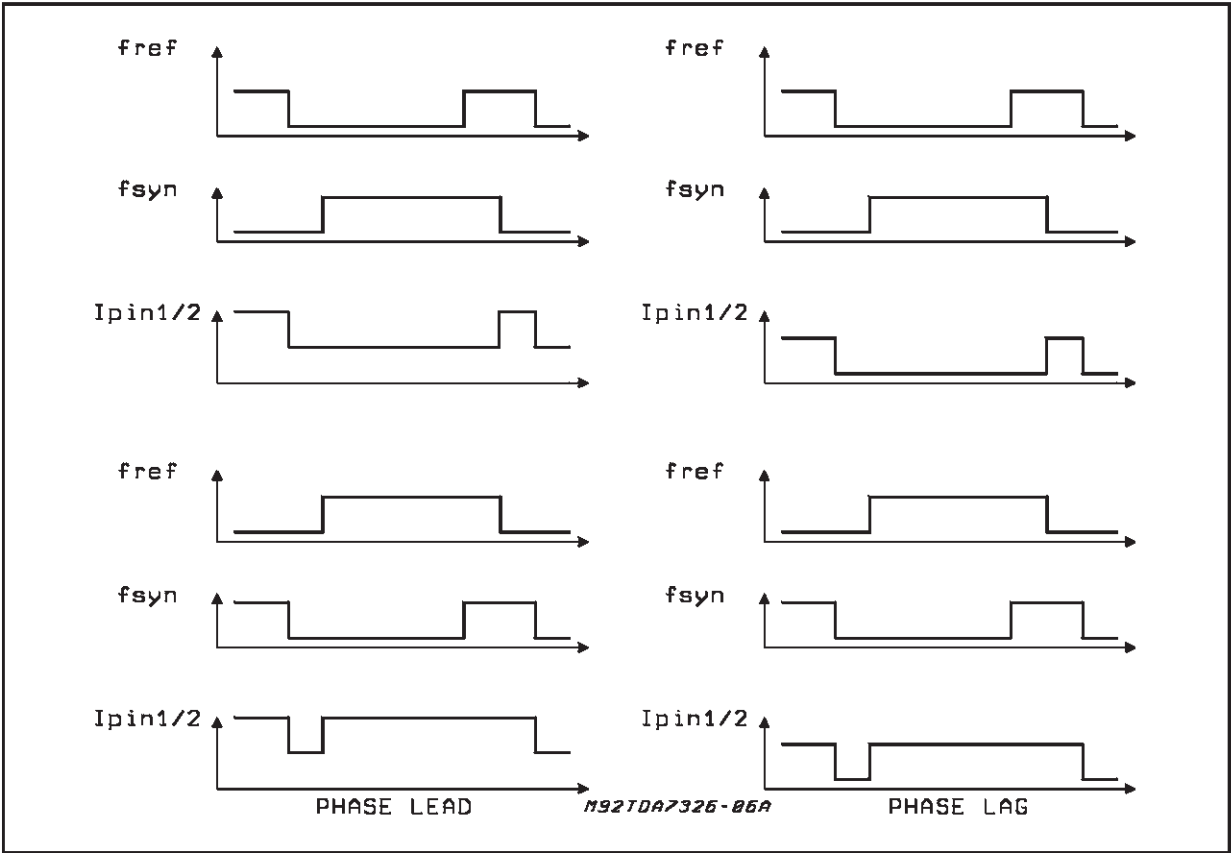
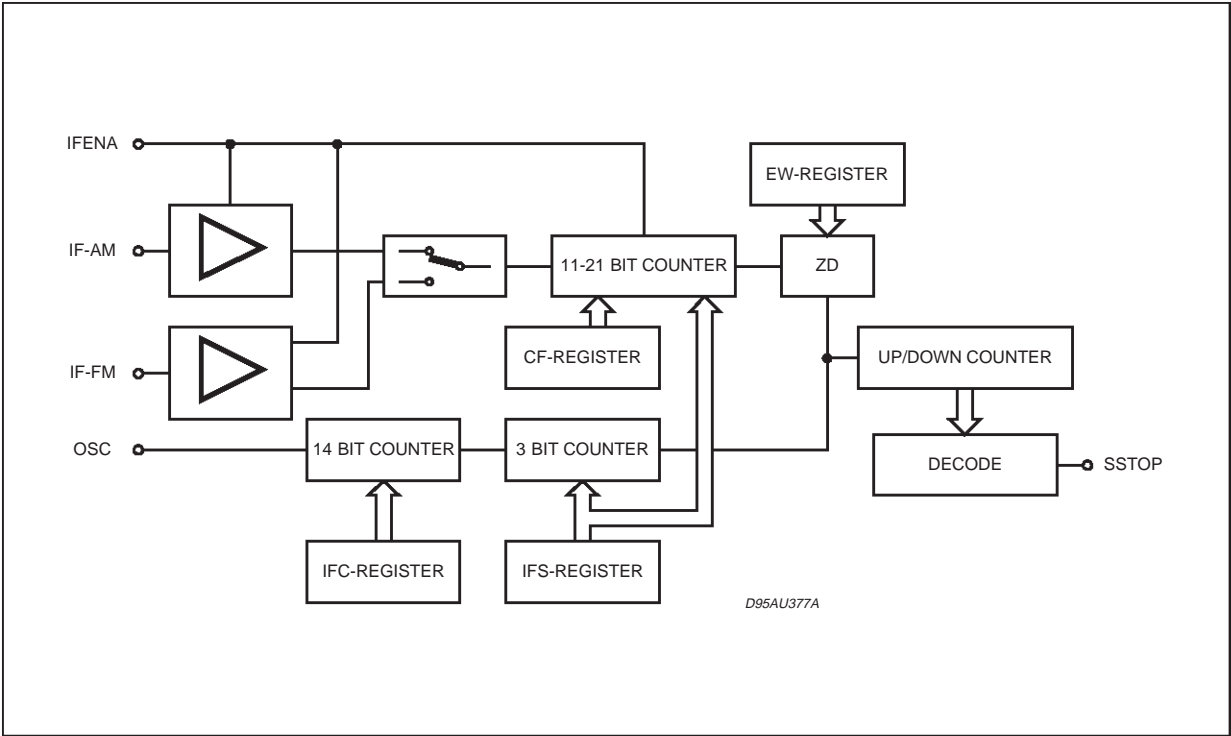

Figure 4. IF Counter internal block diagram



The negative input is switchable to three input pins (LPIN 1, LPIN 2 and LPIN 3) to increase the flexibility in application. This feature allows two separate active filters for different applications

A logical "1" in the LPIN 1/2 register activates pin LPIN 1, otherwise pin LPIN 2 is active. While the high current mode is activated LPIN 3 is switched on.

INLOCK DETECTOR

The charge pump can be switched in low current mode either via software or automatically by the inlock detector by setting bit LDENA to "1".

The charge pump is forced in low current mode when a phase difference of 10-40 nsec is reached.

A phase difference larger then the programmed values will switch the charge pump immediately in the high current mode.

Programmable delays are available for inlock detection.

IF COUNTER SYSTEM (AM/FM/AM - UPC MODES)

The if counter works in modes controlled by IFCM register (see table):

IFCM1	IFCM0	FUNCTION
0	0	NOT USED
0	1	FM MODE
1	0	AM MODE
1	1	10.7MHz AM UP CONVERSION MODE

Typical input impedance for IF inputs is 4KΩ.

A sample timer to generate the gate signal for the main counter is build with a 14-bit programmable counter to have the possibility to use any crystal oscillator frequency. In FM mode 6.25KHz in AM

mode a 1KHz signal is generated. This is followed by an asynchronous divider to generate different sampling times (see fig. 4).

Intermediate Frequency Main Counter

This counter is a 11/21 bits synchronous autoreload down-counter. Four bits are programmable to have the possibility for an adjust to the frequency of the CF filter. The counter length is automatically adjusted to the chosen sampling time and the counter mode (AM, FM, AM-UPC).

At the start the counter will be loaded with a defined value which is an equivalent to the divider value ($t_{sample} \cdot f_{IF}$).

If a correct frequency is applied to the IF counter frequency inputs IF-AM IF-FM, at the end of the sampling time the main counter is changing its state from 0 H to 1FFFFFFH.

This is detected by a control logic. The frequency range inside which a successful count results is detected is adjustable by bits EW 0,1,2.

Adjustment of the Measurement Sequence Time

The precision of the measurements is adjustable by controlling the discrimination window .

This is adjustable by programming the control registers EW0...EW2.

The measurement time per cycle is adjustable by setting the Register IFS0 - IFS2.

Adjust of the Frequency Value

The center frequency of the discrimination window is adjustable by the control register "CF0" to "CF4". (see data byte specification).

Port Extension and additional functions

One digital open collector output and one digital push-pull output are available in application mode. This digital ports are controlled by the data bits DOUT1 and DOUT3.

Figure 5. I²C Bus timing diagram

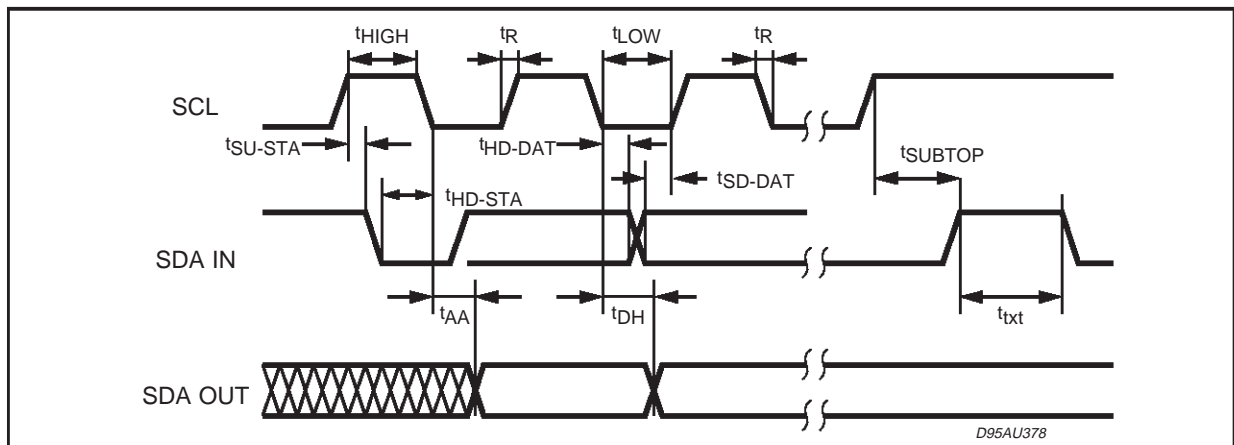

TDA7427

dress being transmitted.

After this comparison, the TDA7427 will generate an "acknowledge" on the SDA line and will perform either a read or write operation according to the state of R/W bit.

Write Operation

Following a START condition the master sends a slave address word with the R/W bit set to "0". The TDA7427 will "acknowledge" after this first transmission and wait for a second word (the word address field).

This 8 bit address field provides an access to any of the 8 internal addresses. Upon receipt of the word address the TDA7427 slave device will respond with an "acknowledge". At this time, all the

following words transmitted to the TDA7427 will be considered as Data. The internal address will be automatically incremented. After each word receipt the TDA7427 will answer with an "acknowledge".

SOFTWARE SPECIFICATION

I²C Protocol

The interface protocol comprises:

- A start condition (s)
- A chip address byte (the LSB determines read/write transmission)
- A sub-address byte.
- A sequence of data (N-bytes + acknowledge)
- A stop condition (P)

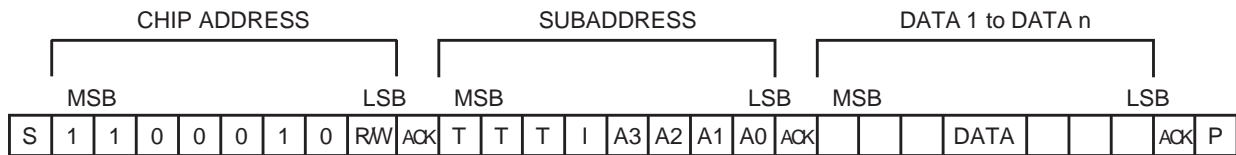

ACK = Acknowledge

S = Start

P = Stop

I = Auto Increment

T = used for testing (in application mode they have to be "0")

MAX CLOCK SPEED 400kbits/s

CHIP ADDRESS

MSB								LSB
	1	1	0	0	0	1	0	0

SUBADDRESS

MSB				LSB				FUNCTION
T3	T2	T1	I	A3	A2	A1	A0	
				0	0	0	0	Charge pump control
				0	0	0	1	PLL counter 1 (LSB)
				0	0	1	0	PLL counter 2 (MSB)
				0	0	1	1	PLL reference counter 1 (LSB)
				0	1	0	0	PLL reference counter 2 (MSB)
				0	1	0	1	PLL lockdetector control and PLL mode select
				0	1	1	0	IFC reference counter 1 (LSB)
				0	1	1	1	IFC reference counter 2 (MSB) and IFC mode select
				1	0	0	0	IF counter control 1
				1	0	0	1	IF counter control 2
				1	0	1	0	Oscillator adjust
				1	0	1	1	Port extension
			0					page mode off
			1					page mode enabled

T1, T2, T3 used for testing, in application mode they have to be "0"

Data Byte Specification

CHARGE PUMP CONTROL

MSB				LSB				FUNCTION
D7	D6	D5	D4	D3	D2	D1	D0	
				0	0	0	0	High current = 0mA
				0	0	0	1	High current = 0.5mA
				0	0	1	0	High current = 1.0mA
				0	0	1	1	High current = 1.5mA
				0	1	0	0	High current = 2.0mA
				0	1	0	1	High current = 2.5mA
				0	1	1	0	High current = 3.0mA
				0	1	1	1	High current = 3.5mA
				1	0	0	0	High current = 4.0mA
				1	0	0	1	High current = 4.5mA
				1	0	1	0	High current = 5.0mA
				1	0	1	1	High current = 5.5mA
				1	1	0	0	High current = 6.0mA
				1	1	0	1	High current = 6.5mA
				1	1	1	0	High current = 7.0mA
				1	1	1	1	High current = 7.5mA
		0	0					Low current = 0µA
		0	1					Low current = 50µA
		1	0					Low current = 100µA
		1	1					Low current = 150µA
	0							Select low Current
	1							Select high Current
1								Select loop filter LP_FM
0								Select loop filter LP_AM
LPIN1/2	CURRH	B1	B0	A3	A2	A1	A0	Subaddress = 00H

PLL COUNTER 1 (LSB)

MSB				LSB				FUNCTION
D7	D6	D5	D4	D3	D2	D1	D0	
0	0	0	0	0	0	0	0	LSB = 0
0	0	0	0	0	0	0	1	LSB = 1
0	0	0	0	0	0	1	0	LSB = 2
1	1	1	1	1	1	0	0	LSB = 252
1	1	1	1	1	1	0	1	LSB = 253
1	1	1	1	1	1	1	0	LSB = 254
1	1	1	1	1	1	1	1	LSB = 255
PC7	PC6	PC5	PC4	PC3	PC2	PC1	PC0	Bit name Subaddress = 01H

TDA7427

PLL COUNTER 2 (MSB)

MSB								LSB	FUNCTION
D7	D6	D5	D4	D3	D2	D1	D0		
0	0	0	0	0	0	0	0	MSB = 0	
0	0	0	0	0	0	0	1	MSB = 256	
0	0	0	0	0	0	1	0	MSB = 512	
1	1	1	1	1	1	0	0	MSB = 64768	
1	1	1	1	1	1	0	1	MSB = 65024	
1	1	1	1	1	1	1	0	MSB = 65280	
1	1	1	1	1	1	1	1	MSB = 65536	
PC15	PC14	PC13	PC12	PC11	PC10	PC9	PC8	Bit name Subaddress = 02H	

Swallow mode: $f_{vco}/f_{syn} = LSB + MSB + 32$

Direct mode: $f_{vco}/f_{syn} = LSB + MSB + 1$

PLL REFERENCE COUNTER 1 (LSB)

MSB								LSB	FUNCTION
D7	D6	D5	D4	D3	D2	D1	D0		
0	0	0	0	0	0	0	0	LSB = 0	
0	0	0	0	0	0	0	1	LSB = 1	
0	0	0	0	0	0	1	0	LSB = 2	
1	1	1	1	1	1	0	0	LSB = 252	
1	1	1	1	1	1	0	1	LSB = 253	
1	1	1	1	1	1	1	0	LSB = 254	
1	1	1	1	1	1	1	1	LSB = 255	
RC7	RC6	RC5	RC4	RC3	RC2	RC1	RC0	Bit name Subaddress = 03H	

PLL REFERENCE COUNTER 2 (MSB)

MSB								LSB	FUNCTION
D7	D6	D5	D4	D3	D2	D1	D0		
0	0	0	0	0	0	0	0	MSB = 0	
0	0	0	0	0	0	0	1	MSB = 256	
0	0	0	0	0	0	1	0	MSB = 512	
1	1	1	1	1	1	0	0	MSB = 64768	
1	1	1	1	1	1	0	1	MSB = 65024	
1	1	1	1	1	1	1	0	MSB = 65280	
1	1	1	1	1	1	1	1	MSB = 65536	
RC15	RC14	RC13	RC12	RC11	RC10	RC9	RC8	Bit name Subaddress = 04H	

$f_{osc}/f_{REF} = LSB + MSB + 1$

LOCK DETECTOR & PLL MODE CONTROL

MSB							LSB		FUNCTION
D7	D6	D5	D4	D3	D2	D1	D0		
						0	0	PLL standby mode	
						0	1	PLL AM swallow mode	
						1	0	PLL AM direct mode	
						1	1	PLL FM mode	
				0	0			PD phase difference threshold 10ns	
				0	1			PD phase difference threshold 20ns	
				1	0			PD phase difference threshold 30ns	
				1	1			PD phase difference threshold 40ns	
		0	0					Not used in application mode	
		0	1					Activation delay = 4 · fref	
		1	0					Activation delay = 6 · fref	
		1	1					Activation delay = 8 · fref	
	0							Digital output 1 at pin "dout1/inlock"	
	1							Inlock information at pin "dout1/inlock"	
0								No lock detector controlled chargepump	
1								Lock detector controlled chargepump	
LDENA	INLOCK	D3	D2	D1	D0	PM1	PM0	Bit name Subaddress = 05H	

IF COUNTER REFERENCE CONTROL 1 (LSB)

MSB							LSB		FUNCTION
D7	D6	D5	D4	D3	D2	D1	D0		
0	0	0	0	0	0	0	0	LSB = 0	
0	0	0	0	0	0	0	1	LSB = 1	
0	0	0	0	0	0	1	0	LSB = 2	
1	1	1	1	1	1	0	0	LSB = 252	
1	1	1	1	1	1	0	1	LSB = 253	
1	1	1	1	1	1	1	0	LSB = 254	
1	1	1	1	1	1	1	1	LSB = 255	
IRC7	IRC6	IRC5	IRC4	IRC3	IRC2	IRC1	IRC0	Bit name Subaddress = 06H	

IF COUNTER REFERENCE CONTROL 2 (MSB) AND IF COUNTER MODE SELECT

MSB								LSB		FUNCTION
D7	D6	D5	D4	D3	D2	D1	D0			
0	0	0	0	0	0	0	0	MSB = 0		
0	0	0	0	0	0	0	1	MSB = 256		
0	0	0	0	0	0	1	0	MSB = 512		
		1	1	1	1	0	1	MSB = 15616		
		1	1	1	1	1	0	MSB = 15872		
		1	1	1	1	1	1	MSB = 16128		
0	0							NOT USED IN APPLICATION MODE		
0	1							IF counter FM mode		
1	0							IF counter AM mode		
1	1							IF counter AM 10.7MHz upconversion mode		
IFCM1	IFCM0	IRC13	IRC12	IRC11	IRC10	IRC9	IRC8	Bit name	Subaddress = 07H	

fosc/ftim = LSB + MSB + 1

IF COUNTER CONTROL 1

MSB								LSB		FUNCTION
D7	D6	D5	D4	D3	D2	D1	D0			
					0	0	0	don't use		
					0	0	1	don't use		
					0	1	1	EW delta f = ±6.25kHz (FM); ±1kHz (AM; AM-UPC)		
					1	0	0	EW delta f = ±12.5kHz (FM); ±2kHz (AM; AM-UPC)		
					1	0	1	EW delta f = ±25kHz (FM); ±4kHz (AM; AM-UPC)		
					1	1	0	EW delta f = ±50Hz (FM); ±8kHz (AM; AM-UPC)		
					1	1	1	EW delta f = ±100kHz (FM); ±16kHz (AM; AM-UPC)		
	X	X	X	X				don't use		
0								IF counter disabled / stand by		
1								IF counter enabled		
FENA	FR3	FR2	FR1	FR0	EW2	EW1	EW0	Bit name	Subaddress = 08H	

IF COUNTER CONTROL 2

MSB				LSB				FUNCTION
D7	D6	D5	D4	D3	D2	D1	D0	
			0	0	0	0	0	fcenter = 10.60000MHz (FM) 448KHz (AM) 10.688MHz (AM UPC)
			0	0	0	0	1	fcenter = 10.60625MHz (FM) 449KHz (AM) 10.689MHz (AM UPC)
			0	0	0	1	0	fcenter = 10.61250MHz (FM) 450KHz (AM) 10.690MHz (AM UPC)
			0	0	0	1	1	fcenter = 10.61875MHz (FM) 451KHz (AM) 10.691MHz (AM UPC)
			0	0	1	0	0	fcenter = 10.62500MHz (FM) 452KHz (AM) 10.692MHz (AM UPC)
			0	0	1	0	1	fcenter = 10.63125MHz (FM) 453KHz (AM) 10.693MHz (AM UPC)
			0	0	1	1	0	fcenter = 10.63750MHz (FM) 454KHz (AM) 10.694MHz (AM UPC)
			0	0	1	1	1	fcenter = 10.64375MHz (FM) 455KHz (AM) 10.695MHz (AM UPC)
			0	1	0	0	0	fcenter = 10.65000MHz (FM) 456KHz (AM) 10.696MHz (AM UPC)
			0	1	0	0	1	fcenter = 10.65625MHz (FM) 457KHz (AM) 10.697MHz (AM UPC)
			0	1	0	1	0	fcenter = 10.66250MHz (FM) 458KHz (AM) 10.698MHz (AM UPC)
			0	1	0	1	1	fcenter = 10.66875MHz (FM) 459KHz (AM) 10.699MHz (AM UPC)
			0	1	1	0	0	fcenter = 10.67500MHz (FM) 460KHz (AM) 10.700MHz (AM UPC)
			0	1	1	0	1	fcenter = 10.68125MHz (FM) 461KHz (AM) 10.701MHz (AM UPC)
			0	1	1	1	0	fcenter = 10.68750MHz (FM) 462KHz (AM) 10.702MHz (AM UPC)
			0	1	1	1	1	fcenter = 10.69375MHz (FM) 463KHz (AM) 10.703MHz (AM UPC)
			1	0	0	0	0	fcenter = 10.70000MHz (FM) 464KHz (AM) 10.704MHz (AM UPC)
			1	0	0	0	1	fcenter = 10.70625MHz (FM) 465KHz (AM) 10.705MHz (AM UPC)
			1	0	0	1	0	fcenter = 10.71250MHz (FM) 466KHz (AM) 10.706MHz (AM UPC)
			1	0	0	1	1	fcenter = 10.71875MHz (FM) 467KHz (AM) 10.707MHz (AM UPC)
			1	0	1	0	0	fcenter = 10.72500MHz (FM) 468KHz (AM) 10.708MHz (AM UPC)
			1	0	1	0	1	fcenter = 10.73125MHz (FM) 469KHz (AM) 10.709MHz (AM UPC)
			1	0	1	1	0	fcenter = 10.73750MHz (FM) 470KHz (AM) 10.710MHz (AM UPC)
			1	0	1	1	1	fcenter = 10.74375MHz (FM) 471KHz (AM) 10.711MHz (AM UPC)
			1	1	0	0	0	fcenter = 10.75000MHz (FM) 472KHz (AM) 10.712MHz (AM UPC)
			1	1	0	0	1	fcenter = 10.75625MHz (FM) 473KHz (AM) 10.713MHz (AM UPC)
			1	1	0	1	0	fcenter = 10.76250MHz (FM) 474KHz (AM) 10.714MHz (AM UPC)
			1	1	0	1	1	fcenter = 10.76875MHz (FM) 475KHz (AM) 10.715MHz (AM UPC)
			1	1	1	0	0	fcenter = 10.77500MHz (FM) 476KHz (AM) 10.716MHz (AM UPC)
			1	1	1	0	1	fcenter = 10.78125MHz (FM) 477KHz (AM) 10.717MHz (AM UPC)
			1	1	1	1	0	fcenter = 10.78750MHz (FM) 478KHz (AM) 10.718MHz (AM UPC)
			1	1	1	1	1	fcenter = 10.79375MHz (FM) 479KHz (AM) 10.719MHz (AM UPC)
1	1	1						tsample = 160µs (FM mode); 1ms (AM; AM-UPC)
1	1	0						tsample = 320µs (FM mode); 2ms (AM; AM-UPC)
1	0	1						tsample = 640µs (FM mode); 4ms (AM; AM-UPC)
1	0	0						tsample = 1.280ms (FM mode); 8ms (AM; AM-UPC)
0	1	1						tsample = 2.560ms (FM mode); 16ms (AM; AM-UPC)
0	1	0						tsample = 5.120ms (FM mode); 32ms (AM; AM-UPC)
0	0	1						tsample = 10.240ms (FM mode); 64ms (AM; AM-UPC)
0	0	0						tsample = 20.480ms (FM mode); 128ms (AM; AM-UPC)
IFS2	IFS1	IFS0	CF4	CF3	CF2	CF1	CF0	bit same Subaddress = 09H

OSCILLATOR ADJUST

MSB				LSB				FUNCTION
D7	D6	D5	D4	D3	D2	D1	D0	
X	X	X	0	0	0	0	0	Cload 1,2 = 3pF
X	X	X	0	0	0	0	1	Cload 1,2 = 4.25pF
X	X	X	0	0	0	1	0	Cload 1,2 = 5.5pF
X	X	X	0	0	0	1	1	Cload 1,2 = 6.75pF
X	X	X	0	0	1	0	0	Cload 1,2 = 8pF
X	X	X	0	0	1	0	1	Cload 1,2 = 9.25pF
X	X	X	0	0	1	1	0	Cload 1,2 = 10.5pF
X	X	X	0	0	1	1	1	Cload 1,2 = 11.75pF
X	X	X	0	1	0	0	0	Cload 1,2 = 13pF
X	X	X	0	1	0	0	1	Cload 1,2 = 14.25pF
X	X	X	0	1	0	1	0	Cload 1,2 = 15.5pF
X	X	X	0	1	0	1	1	Cload 1,2 = 16.75pF
X	X	X	0	1	1	0	0	Cload 1,2 = 18pF
X	X	X	0	1	1	0	1	Cload 1,2 = 19.25pF
X	X	X	0	1	1	1	0	Cload 1,2 = 20.5pF
X	X	X	0	1	1	1	1	Cload 1,2 = 21.75pF
X	X	X	1	0	0	0	0	Cload 1,2 = 23pF
X	X	X	1	0	0	0	1	Cload 1,2 = 24.25pF
X	X	X	1	0	0	1	0	Cload 1,2 = 25.5pF
X	X	X	1	0	0	1	1	Cload 1,2 = 26.75pF
X	X	X	1	0	1	0	0	Cload 1,2 = 28pF
X	X	X	1	0	1	0	1	Cload 1,2 = 29.25pF
X	X	X	1	0	1	1	0	Cload 1,2 = 30.5pF
X	X	X	1	0	1	1	1	Cload 1,2 = 31.75pF
X	X	X	1	1	0	0	0	Cload 1,2 = 33pF
X	X	X	1	1	0	0	1	Cload 1,2 = 34.25pF
X	X	X	1	1	0	1	0	Cload 1,2 = 35.5pF
X	X	X	1	1	0	1	1	Cload 1,2 = 36.75pF
X	X	X	1	1	1	0	0	Cload 1,2 = 38pF
X	X	X	1	1	1	0	1	Cload 1,2 = 39.25pF
X	X	X	1	1	1	1	0	Cload 1,2 = 40.5pF
X	X	X	1	1	1	1	1	Cload 1,2 = 41.75pF
-	-	-	OSC4	OSC3	OSC2	OSC1	OSC0	Bit name Subaddress = 0AH

PORT EXTENSION CONTROL

MSB		LSB		FUNCTION
D7	D6	D2	D0	
			0	CMOS push-pull DOUT1 low
			1	CMOS push-pull DOUT1 high
		0		NPN opencollector DOUT3 inactive
		1		NPN opencollector DOUT3 active
0	0			always "0" in application mode
-	-	DOUT3	DOUT1	Bit name Subaddress = 0BH

DIM.	mm			inch		
	MIN.	TYP.	MAX.	MIN.	TYP.	MAX.
a1	0.254			0.010		
B	1.39		1.65	0.055		0.065
b		0.45			0.018	
b1		0.25			0.010	
D			25.4			1.000
E		8.5			0.335	
e		2.54			0.100	
e3		22.86			0.900	
F			7.1			0.280
I			3.93			0.155
L		3.3			0.130	
Z			1.34			0.053

OUTLINE AND MECHANICAL DATA

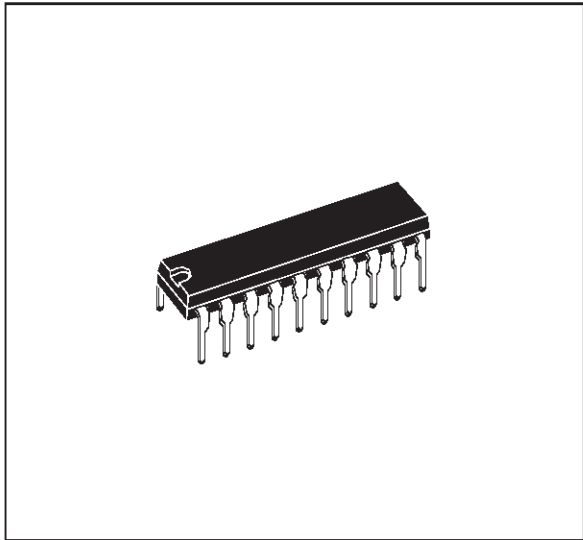

DIP20

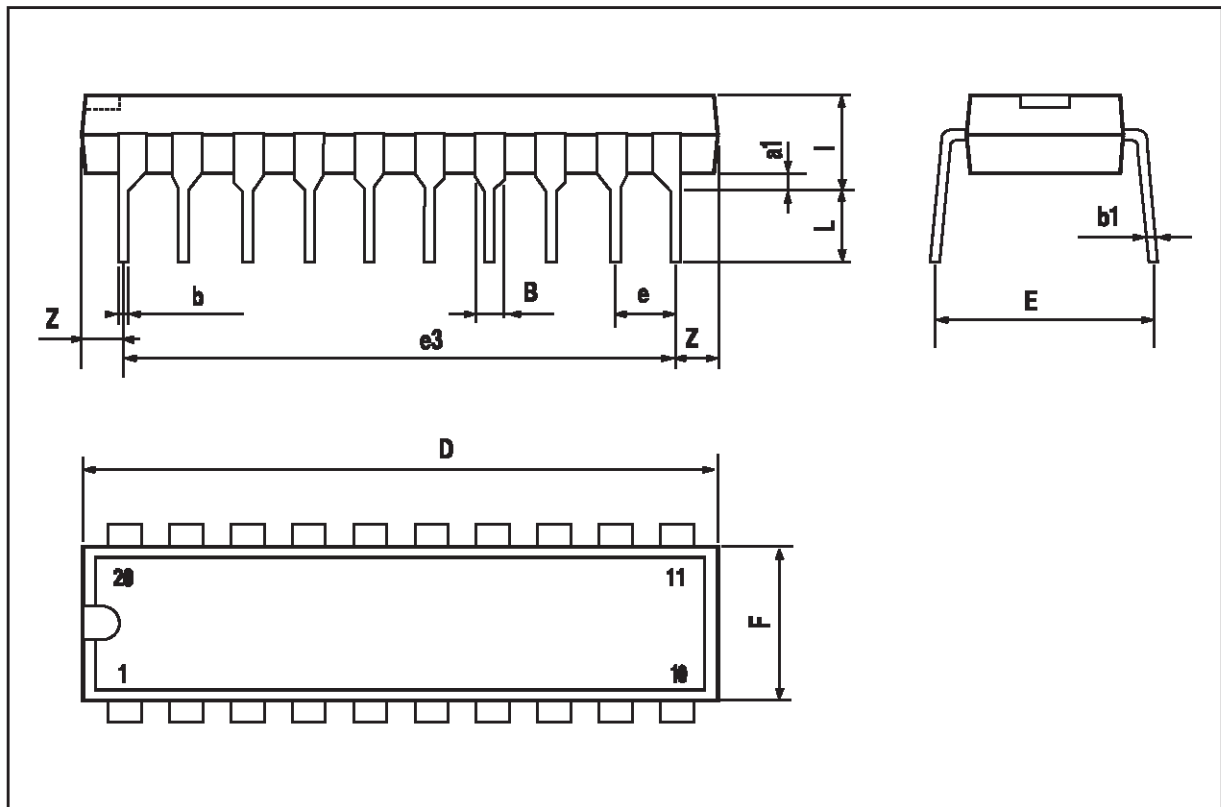

DIM.	mm			inch		
	MIN.	TYP.	MAX.	MIN.	TYP.	MAX.
A	2.35		2.65	0.093		0.104
A1	0.1		0.3	0.004		0.012
B	0.33		0.51	0.013		0.020
C	0.23		0.32	0.009		0.013
D	12.6		13	0.496		0.512
E	7.4		7.6	0.291		0.299
e		1.27			0.050	
H	10		10.65	0.394		0.419
h	0.25		0.75	0.010		0.030
L	0.4		1.27	0.016		0.050
K	0° (min.)8° (max.)					

OUTLINE AND MECHANICAL DATA

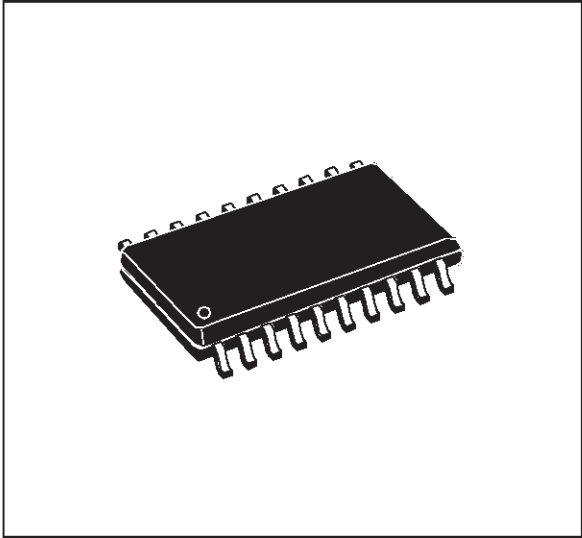

SO20

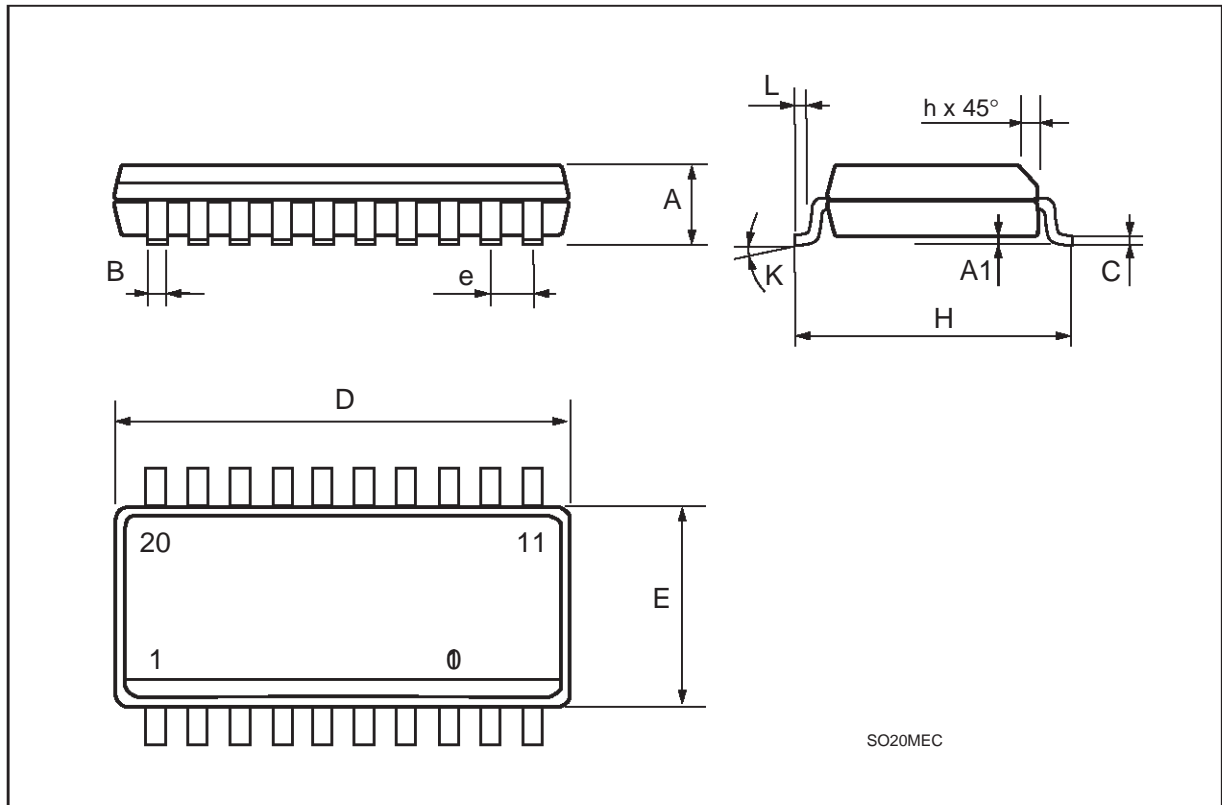

SO20MEC

Information furnished is believed to be accurate and reliable. However, STMicroelectronics assumes no responsibility for the consequences of use of such information nor for any infringement of patents or other rights of third parties which may result from its use. No license is granted by implication or otherwise under any patent or patent rights of STMicroelectronics. Specification mentioned in this publication are subject to change without notice. This publication supersedes and replaces all information previously supplied. STMicroelectronics products are not authorized for use as critical components in life support devices or systems without express written approval of STMicroelectronics.

The ST logo is a registered trademark of STMicroelectronics

© 1999 STMicroelectronics – Printed in Italy – All Rights Reserved

STMicroelectronics GROUP OF COMPANIES

Australia - Brazil - China - Finland - France - Germany - Hong Kong - India - Italy - Japan - Malaysia - Malta - Morocco -
Singapore - Spain - Sweden - Switzerland - United Kingdom - U.S.A.

<http://www.st.com>