

阅读申明

- 1.本站收集的数据手册和产品资料都来自互联网，版权归原作者所有。如读者和版权方有任何异议请及时告之，我们将妥善解决。
- 2.本站提供的中文数据手册是英文数据手册的中文翻译，其目的是协助用户阅读，该译文无法自动跟随原稿更新，同时也可能存在翻译上的不当。建议读者以英文原稿为参考以便获得更精准的信息。
- 3.本站提供的产品资料，来自厂商的技术支持或者使用者的心得体会等，其内容可能存在描述上的差异，建议读者做出适当判断。
- 4.如需与我们联系，请发邮件到marketing@iczoom.com，主题请标有“数据手册”字样。

Read Statement

1. The datasheets and other product information on the site are all from network reference or other public materials, and the copyright belongs to the original author and original published source. If readers and copyright owners have any objections, please contact us and we will deal with it in a timely manner.
2. The Chinese datasheets provided on the website is a Chinese translation of the English datasheets. Its purpose is for reader's learning exchange only and do not involve commercial purposes. The translation cannot be automatically updated with the original manuscript, and there may also be improper translations. Readers are advised to use the English manuscript as a reference for more accurate information.
3. All product information provided on the website refer to solutions from manufacturers' technical support or users the contents may have differences in description, and readers are advised to take the original article as the standard.
4. If you have any questions, please contact us at marketing@iczoom.com and mark the subject with "Datasheets" .

Phase-Locked Loop Clock Driver

Product Features

- High-Performance Phase-Locked-Loop Clock Distribution for Networking,
- Synchronous DRAM modules for server/workstation/PC applications
- Allows Clock Input to have Spread Spectrum modulation for EMI reduction
- Zero Input-to-Output delay
- Low jitter: Cycle-to-Cycle jitter ± 75 ps max.
- On-chip series damping resistor at clock output drivers for low noise and EMI reduction
- Operates at 3.3V V_{CC}
- Wide range of Clock Frequencies 80 to 134 MHz
- Package: Plastic 8-pin SOIC Package (W)

Product Description

The PI6C2502A features a low-skew, low-jitter, phase-locked loop (PLL) clock driver. By connecting the feedback FB_OUT output to the feedback FB_IN input, the propagation delay from the CLK_IN input to any clock output will be nearly zero.

Application

If a system designer needs more than 16 outputs with the features just described, using two or more zero-delay buffers such as PI6C2509Q, and PI6C2510Q, is likely to be impractical. The device-to-device skew introduced can significantly reduce the performance. Pericom recommends the use of a zero-delay buffer and an eighteen output non-zero-delay buffer. As shown in Figure 1, this combination produces a zero-delay buffer with all the signal characteristics of the original zero-delay buffer, but with as many outputs as the non-zero-delay buffer part. For example, when combined with an eighteen output non-zero delay buffer, a system designer can create a seventeen-output zero-delay buffer.

Logic Block Diagram

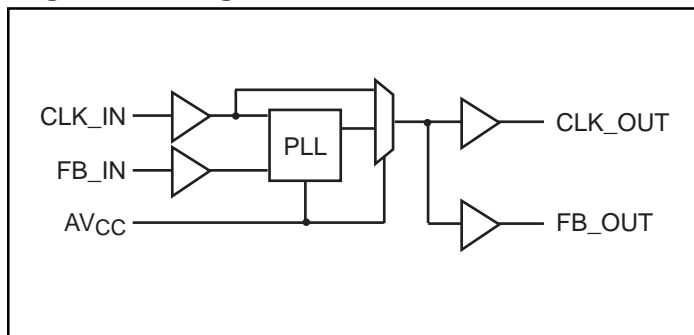

Product Pin Configuration

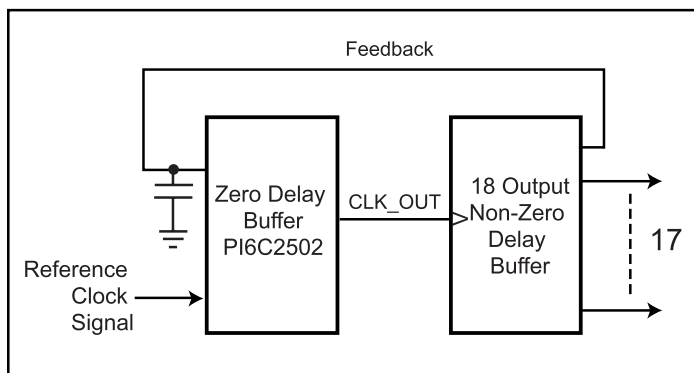
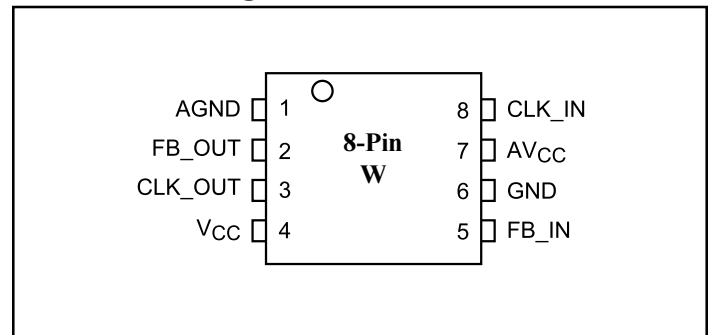

Figure 1. This Combination Provides Zero-Delay Between the Reference Clocks Signal and 17 Outputs.

Pin Functions

| Pin Name | Pin Number | Type | Description |
|------------------|------------|--------|---|
| CLK_IN | 8 | I | Reference Clock input. CLK_IN allows spread spectrum clock input. |
| FB_IN | 5 | I | Feedback input. FB_IN provides the feedback signal to the internal PLL. |
| FB_OUT | 2 | O | Feedback output FB_OUT is dedicated for external feedback. FB_OUT has an embedded series-damping resistor of the same value as the clock outputs CLK_OUT. |
| CLK_OUT | 3 | O | Clock outputs. These outputs provide low-skew copies of CLK_IN. Each output has an embedded series-damping resistor. |
| AV _{CC} | 7 | Power | Analog power supply. AV _{CC} can be also used to bypass the PLL for test purposes. When AV _{CC} is strapped to ground, PLL is bypassed and CLK_IN is buffered directly to the device outputs. |
| AGND | 1 | Ground | Analog ground. AGND provides the ground reference for the analog circuitry. |
| V _{CC} | 4 | Power | Power supply. |
| GND | 6 | Ground | Ground. |

DC Specifications (Absolute maximum ratings over operating free-air temperature range)

| Symbol | Parameter | Min. | Max. | Units |
|-------------------|---|------|-----------------------|-------|
| V _I | Input voltage range | -0.5 | V _{CC} + 0.5 | V |
| V _O | Output voltage range | | | |
| V _{I,DC} | DC input voltage | | 3.8 | |
| I _{O,DC} | DC output current | | 100 | mA |
| Power | Maximum power dissipation at T _A = 55°C in still air | | 1.0 | W |
| T _{STG} | Storage temperature | -65 | 150 | °C |

Note:

Stress beyond those listed under “absolute maximum ratings” may cause permanent damage to the device.

| Parameter | Test Conditions | V _{CC} | Min. | Typ. | Max. | Units |
|-----------------|--|-----------------|------|------|------|-------|
| I _{CC} | V _I = V _{CC} or GND; I _O = 0 ⁽¹⁾ Standby Current | 3.6V | | | 10 | μA |
| C _I | V _I = V _{CC} or GND | 3.3V | | 4 | | pF |
| C _O | V _O = V _{CC} or GND | | | 6 | | |

Note:

1. Continuous Output Current

Recommended Operating Conditions

| Symbol | Parameter | Min. | Max. | Units |
|-----------------|--------------------------------|------|-----------------|-------|
| V _{CC} | Supply voltage | 3.0 | 3.6 | V |
| V _{IH} | High level input voltage | 2.0 | | |
| V _{IL} | Low level input voltage | | 0.8 | |
| V _I | Input voltage | 0 | V _{CC} | |
| T _A | Operating free-air temperature | 0 | 70 | °C |

Electrical Characteristics (Over Recommended Operating Free-Air Temperature Range

Pull Up/Down Currents of PI6C2502A, V_{CC}=3.0V)

| Symbol | Parameter | Condition | Min. | Max. | Units |
|-----------------|-------------------|--------------------------|------|-------|-------|
| I _{OH} | Pull-up current | V _{out} = 2.4V | | -13.6 | mA |
| | Pull-up current | V _{out} = 2.0V | | -22 | |
| I _{OL} | Pull-down current | V _{out} = 0.8V | 19 | | |
| | Pull-down current | V _{out} = 0.55V | 13 | | |

AC Specifications

(Timing requirements over recommended ranges of supply voltage and operating free-air temperature)

| Symbol | Parameter | Min. | Max. | Units |
|------------------|-----------------------------------|------|------|-------|
| F _{CLK} | Clock frequency PI6C2502A | 80 | 134 | MHz |
| D _{CYI} | Input clock duty cycle | 40 | 60 | % |
| | Stabilization Time after power up | | 1 | ms |

Switching Characteristics

(Over recommended ranges of supply voltage and operating free-air temperature, CL = 30pF)

| Parameter | From (Input) | To (Output) | V _{CC} = 3.3V ±0.3V, 0-70°C | | | Units |
|--|-------------------------|-------------|--------------------------------------|------|------|-------|
| | | | Min. | Typ. | Max. | |
| t _{phase error without jitter} | CLK_IN↑ at 100 & 66 MHz | FB_IN↑ | -150 | | +150 | ps |
| Jitter, cycle-to-cycle | At 100 & 66 MHz | CLK_OUT | -75 | | +75 | |
| Duty cycle | | | 45 | | 55 | % |
| t _r , rise-time, 0.4V to 2.0V | | | | 1.0 | | ns |
| t _f , fall-time, 2.0V to 0.4V | | | | 1.1 | | |

Note:

These switching parameters are guaranteed by design.

Package Mechanical Information

Plastic 8-pin SOIC Package

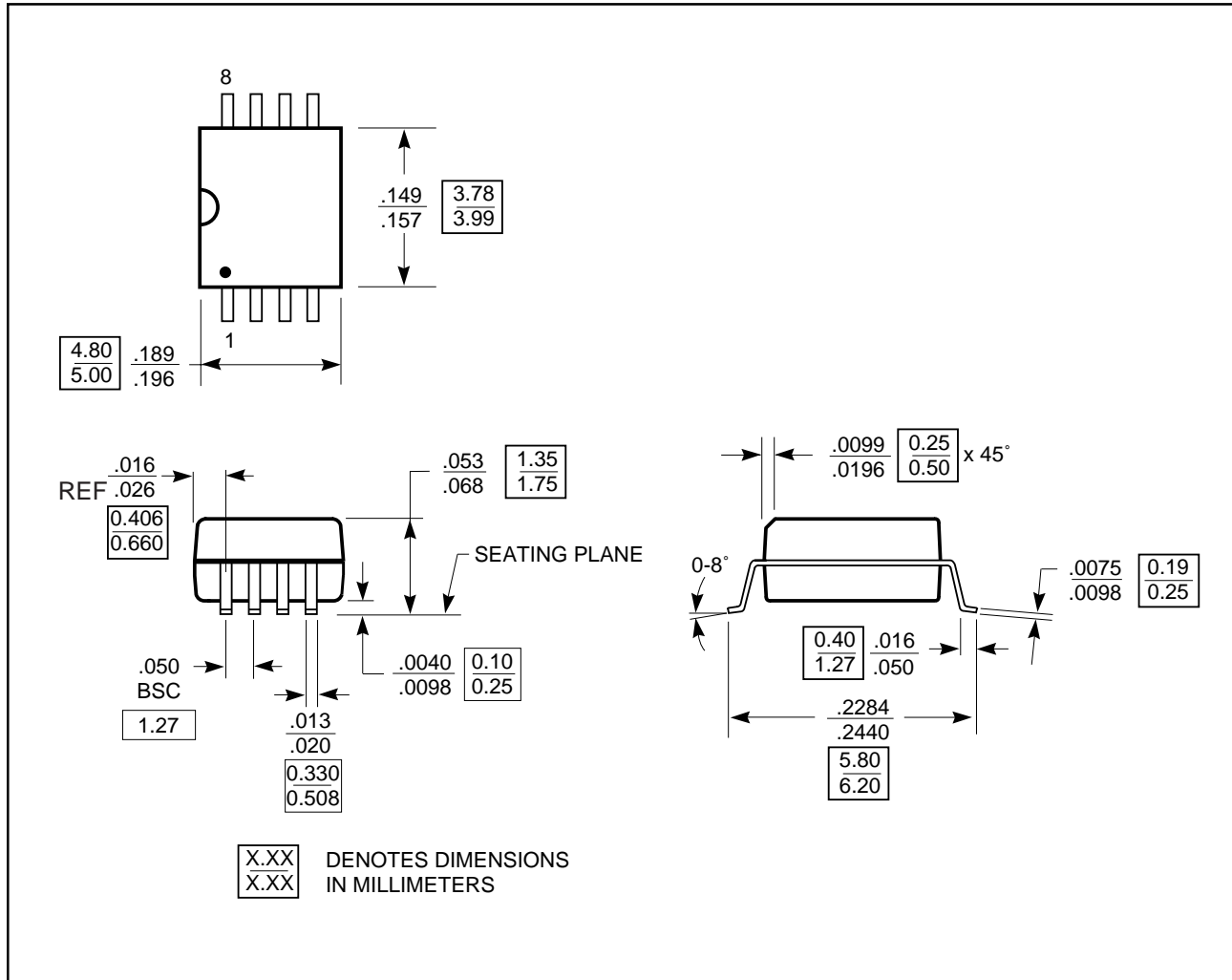

Ordering Information

| Ordering Code | Package Name | Package Type | Operating Range |
|---------------|--------------|--------------------|-----------------|
| PI6C2502AW | W8 | 8-pin 150-mil SOIC | Commercial |