

## 阅读申明

- 1.本站收集的数据手册和产品资料都来自互联网，版权归原作者所有。如读者和版权方有任何异议请及时告之，我们将妥善解决。
- 2.本站提供的中文数据手册是英文数据手册的中文翻译，其目的是协助用户阅读，该译文无法自动跟随原稿更新，同时也可能存在翻译上的不当。建议读者以英文原稿为参考以便获得更精准的信息。
- 3.本站提供的产品资料，来自厂商的技术支持或者使用者的心得体会等，其内容可能存在描述上的差异，建议读者做出适当判断。
- 4.如需与我们联系，请发邮件到marketing@iczoom.com，主题请标有“数据手册”字样。

## Read Statement

1. The datasheets and other product information on the site are all from network reference or other public materials, and the copyright belongs to the original author and original published source. If readers and copyright owners have any objections, please contact us and we will deal with it in a timely manner.
2. The Chinese datasheets provided on the website is a Chinese translation of the English datasheets. Its purpose is for reader's learning exchange only and do not involve commercial purposes. The translation cannot be automatically updated with the original manuscript, and there may also be improper translations. Readers are advised to use the English manuscript as a reference for more accurate information.
3. All product information provided on the website refer to solutions from manufacturers' technical support or users the contents may have differences in description, and readers are advised to take the original article as the standard.
4. If you have any questions, please contact us at marketing@iczoom.com and mark the subject with "Datasheets" .

SERIAL-INTERFACE REAL TIME CLOCK MODULE WITH SRAM

# RTC-4553

Product number (please refer to page 2)

**Q4145535xxxxx00**

- Built-in crystal unit allows adjustment-free efficient operation.
- Automatic calendar function (year, month, day, day of the week, hour, minute, second).
- Automatic leap year correction.
- Built-in 30 x 4-bit S-RAM.
- Reference pulse output. (1024 Hz, 1/10 Hz)

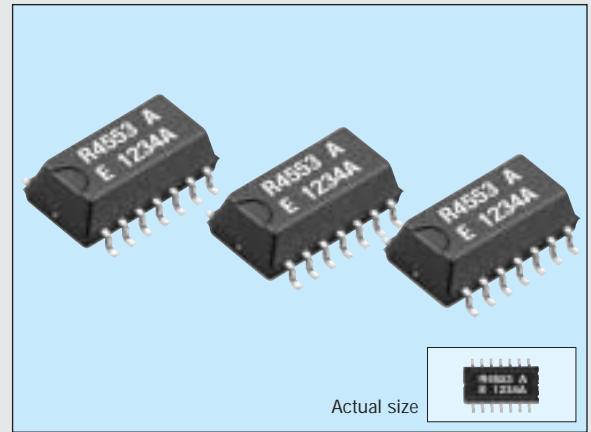

The details are mentioned in the application manual.

<http://www.epsondevice.com>

## Specifications (characteristics)

### Absolute Max. rating

Item	Symbol	Condition	Min.	Max.	Unit
Supply voltage	V <sub>DD</sub>	V <sub>DD</sub> to GND		+6.0	V
Input voltage	V <sub>IN</sub>	S <sub>IN</sub> , S <sub>CK</sub> , WR, CS <sub>0</sub> , CS <sub>1</sub>	-0.3	V <sub>DD</sub> +0.3	
Output voltage	V <sub>OUT</sub>	S <sub>OUT</sub> , TP <sub>OUT</sub>			
Storage temperature	T <sub>STG</sub>	Stored as bare product after unpacking	-55	+125	°C

### Operating range

Item	Symbol	Condition	Min.	Typ.	Max.	Unit
Power voltage	V <sub>DD</sub>	—	2.7	5.0	5.5	V
Clock voltage	V <sub>CLK</sub>	—	2.0	—	5.5	V
Operating temperature	T <sub>OPR</sub>	No condensation	-30	—	+70	°C

### Frequency characteristics

Item	Symbol	Condition	Range	Unit	
Frequency tolerance	Δf/f <sub>0</sub>	T <sub>a</sub> =+25 °C, V <sub>DD</sub> =5 V	AA	5±5	x 10 <sup>-6</sup>
			A	5±10	
			B	5±20	
Oscillation start-up time	t <sub>STA</sub>	T <sub>a</sub> =+25 °C, V <sub>DD</sub> = 3.0 V	3.0 Max.	s	
Frequency temperature characteristics	T <sub>OP</sub>	T <sub>a</sub> =-10 °C to +70 °C, V <sub>DD</sub> =5 V Reference at +25 °C	+10	x 10 <sup>-6</sup>	
			-120		
Frequency voltage characteristics	f/V	T <sub>a</sub> =Fix, V <sub>DD</sub> =2 V to 5.5 V Reference at 5 V	±5	x 10 <sup>-6</sup>	
Aging	f <sub>a</sub>	T <sub>a</sub> =+25 °C, V <sub>DD</sub> =5 V, first year		x 10 <sup>-4</sup> /year	

### DC characteristics (GND=0 V, V<sub>DD</sub>=5 V ± 10 %, T<sub>a</sub>=-30 °C to +70 °C)

Item	Symbol	Condition	Min.	Typ.	Max.	Unit
Current consumption	I <sub>DD1</sub>	S <sub>CK</sub> =500 kHz	—	—	100	μA
	I <sub>DD2</sub>	S <sub>CK</sub> =0 Hz	—	1.0	3.0	
Output voltage	V <sub>OH</sub>	I <sub>OH</sub> =-400 μA	V <sub>DD</sub> -0.4	—	—	V
	V <sub>OL</sub>	I <sub>OL</sub> =1.6 mA	—	—	0.4	
Off leak current	I <sub>OZH</sub>	V <sub>OUT</sub> =5.5 V	-2.0	—	2.0	μA
	I <sub>OZL</sub>	V <sub>OUT</sub> =0 V	—	—	—	
Input voltage	V <sub>IH</sub>	—	4/5 V <sub>DD</sub>	—	—	V
	V <sub>IL</sub>	—	—	—	1/5 V <sub>DD</sub>	
Input current	I <sub>IH</sub>	V <sub>IN</sub> =5.5 V	-2.0	—	2.0	μA
	I <sub>IL</sub>	V <sub>IN</sub> =0 V	—	—	—	

## Terminal connection

### RTC-4553

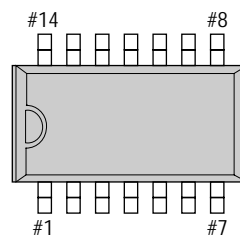

No.	Pin terminal	No.	Pin terminal
1	GND	14	TP <sub>OUT</sub>
2	WR	13	S <sub>OUT</sub>
3	S <sub>IN</sub>	12	CS <sub>1</sub>
4	S <sub>CK</sub>	11	CS <sub>0</sub>
5	L1	10	L5
6	L2	9	L4
7	L3	8	V <sub>DD</sub>

L1 to L5 are test pin. Do not connect them to any terminals.

## External dimensions

(Unit: mm)

### RTC-4553 (SOP 14-pin)

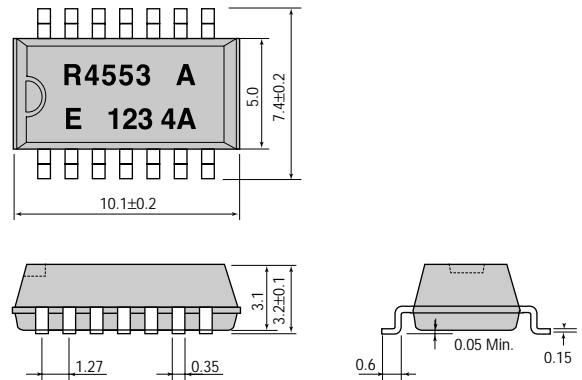

Metal may be exposed on the top or bottom of this product. This won't affect any quality, reliability or electrical spec.

## Block diagram

