

阅读申明

- 1.本站收集的数据手册和产品资料都来自互联网，版权归原作者所有。如读者和版权方有任何异议请及时告之，我们将妥善解决。
- 2.本站提供的中文数据手册是英文数据手册的中文翻译，其目的是协助用户阅读，该译文无法自动跟随原稿更新，同时也可能存在翻译上的不当。建议读者以英文原稿为参考以便获得更精准的信息。
- 3.本站提供的产品资料，来自厂商的技术支持或者使用者的心得体会等，其内容可能存在描述上的差异，建议读者做出适当判断。
- 4.如需与我们联系，请发邮件到marketing@iczoom.com，主题请标有“数据手册”字样。

Read Statement

1. The datasheets and other product information on the site are all from network reference or other public materials, and the copyright belongs to the original author and original published source. If readers and copyright owners have any objections, please contact us and we will deal with it in a timely manner.
2. The Chinese datasheets provided on the website is a Chinese translation of the English datasheets. Its purpose is for reader's learning exchange only and do not involve commercial purposes. The translation cannot be automatically updated with the original manuscript, and there may also be improper translations. Readers are advised to use the English manuscript as a reference for more accurate information.
3. All product information provided on the website refer to solutions from manufacturers' technical support or users the contents may have differences in description, and readers are advised to take the original article as the standard.
4. If you have any questions, please contact us at marketing@iczoom.com and mark the subject with "Datasheets" .



PCM1719

Sound PLUS™ Stereo Audio DIGITAL-TO-ANALOG CONVERTER

FEATURES

- ACCEPTS 16- OR 18-BIT INPUT DATA
- COMPLETE STEREO DAC:
8X Oversampling Digital Filter
Multi-Level Delta-Sigma DAC
Analog Low Pass Filter
- ON-CHIP HEADPHONE AMPLIFIER
- HIGH PERFORMANCE:
-88dB THD+N
96dB Dynamic Range
100dB SNR
- SELECTABLE FUNCTIONS:
Digital De-emphasis
Digital Attenuation (256 Steps)
Soft Mute
Multiple Output Formats
- SYSTEM CLOCK: 256f_s or 384f_s
- SINGLE +5V POWER SUPPLY
- SMALL 28-PIN SSOP PACKAGE

DESCRIPTION

PCM1719 is a complete, low cost stereo audio digital-to-analog converter (DAC) including a digital interpolation filter, 3rd-order delta-sigma DAC, an analog low-pass filter and output amplifier. PCM1719 also has an on-chip stereo headphone amplifier.

PCM1719 can accept either 16-, or 18-bit input data. The audio data input format can be either MSB-first, right-justified or I²S. The system clock can be 256f_s or 384f_s. PCM1719 is fabricated on a highly advanced 0.6μs CMOS process, which delivers high performance at very low power dissipation.

PCM1719 is ideal for applications which require headphone drivers such as CD-ROM drives, digital audio workstations, portable CD players, and digital musical instruments.

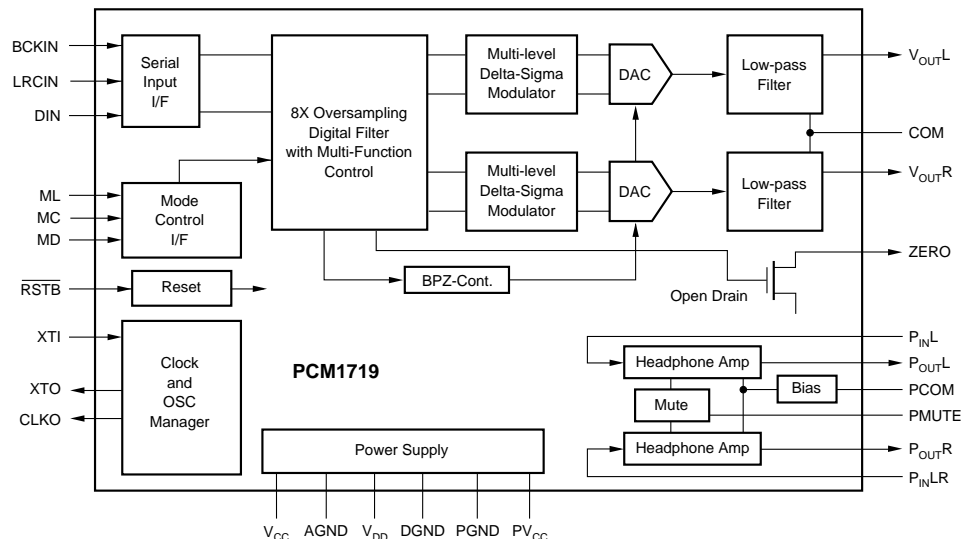

International Airport Industrial Park • Mailing Address: PO Box 11400, Tucson, AZ 85734 • Street Address: 6730 S. Tucson Blvd., Tucson, AZ 85706 • Tel: (520) 746-1111 • Twx: 910-952-1111
Internet: <http://www.burr-brown.com/> • FAXLine: (800) 548-6133 (US/Canada Only) • Cable: BBRCORP • Telex: 066-6491 • FAX: (520) 889-1510 • Immediate Product Info: (800) 548-6132

SPECIFICATIONS

All specifications at +25°C, +V_{DD} = +V_{CC} = PV_{CC} = +5V, f_S = 44.1kHz, SYSCLK = 384f_S, 16-bit data, unless otherwise noted.

PARAMETER	CONDITIONS	PCM1719E			UNITS
		MIN	TYP	MAX	
RESOLUTION		16		18	Bits
DATA FORMAT					
Audio Data Format			Normal/I ² S Selectable		
Data Bit Length			16/18 Bits, Selectable		
Sampling Frequency (f _S)	256f _S /384f _S	32	44.1	48	kHz
System Clock Frequency		8.192/12.288	11.2896/16.9344	12.288/18.432	MHz
DIGITAL INPUT/OUTPUT					
Logic Family			TTL Compatible		
Input Logic Level ^{(2), (3)}					
V _{IH}		2			VDC
V _{IL}				0.8	VDC
Input Logic Current					
I _{IH}				0.8	μA
I _{IL}				-0.8	μA
I _{IH}	V _{IH} = 2.0V			-100	μA
I _{IL}	V _{IL} = 0.0V			-120	μA
I _{IH}	V _{IH} = 2.0V			15	μA
I _{IL}	V _{IL} = 0.0V			-15	μA
I _{IH}	V _{IH} = 2.0V			-60	μA
I _{IL}	V _{IL} = 0.0V			-100	μA
Output Logic Level					
V _{OH}	I _{OH} = -5mA	3.8			VDC
V _{OL}	I _{OL} = 5mA			1.0	VDC
V _{OL}	I _{OL} = 5mA			1.0	VDC
DYNAMIC PERFORMANCE⁽¹⁾					
V_{OUTL}, V_{OUTR}: Line Output⁽⁵⁾					
THD+N at V _O = 0dB	f _{OUT} = 991Hz		-88	-80	dB
at V _O = -60dB	f _{OUT} = 991Hz		-34		dB
Dynamic Range	EIAJ, A-weighted	90	96		dB
Signal-to-Noise Ratio	EIAJ, A-weighted	92	100		dB
Channel Separation	f _{OUT} = 991Hz	90	97		dB
Level Linearity Error	f _{OUT} = 991Hz, -90dB		±0.5		dB
P_{OUTL}, P_{OUTR}: Headphone Output⁽⁶⁾	R _L = 64Ω				
THD+N at V _O = 0dB			-68	-60	dB
Frequency Response	f _{OUT} = 20Hz to 20kHz		±0.1	±0.2	dB
Output Noise Level	EIAJ, A-weighted, R _G = 0Ω		25	30	μVrms
Channel Separation		87	90		dB
Analog Mute Attenuation Level		80	85		dB
DC PERFORMANCE					
V_{OUTL}, V_{OUTR}: Line Output⁽⁵⁾					
Gain Error	R _L = 64Ω		±1	±5	% of FSR
Gain Mismatch Channel-to-Channel			±1	±5	% of FSR
Bipolar Zero Error	V _{OUT} = V _{CC} /2		±30		mV
Analog Output Range			3.1		Vp-p
Center Voltage			V _{CC} /2		V
AC Load Impedance			50% of V _{CC}		VDC
P_{OUTL}, P_{OUTR}: Headphone Output⁽⁶⁾					
Voltage Gain	Load = 64Ω	5	-2.8		dB
Voltage Gain Error	G = -2.8dB		±0.1	±0.2	dB
Input Offset Voltage	Load = 64Ω		±30		mV
Gain Mismatch Channel-to-Channel	Load = 64Ω		±0.1	±0.2	dB
Maximum Output Current			12.5		mArms
Maximum Output Voltage			0.8		Vrms
Output Power			10		mW
AC Load Impedance			64		Ω

The information provided herein is believed to be reliable; however, BURR-BROWN assumes no responsibility for inaccuracies or omissions. BURR-BROWN assumes no responsibility for the use of this information, and all use of such information shall be entirely at the user's own risk. Prices and specifications are subject to change without notice. No patent rights or licenses to any of the circuits described herein are implied or granted to any third party. BURR-BROWN does not authorize or warrant any BURR-BROWN product for use in life support devices and/or systems.

SPECIFICATIONS(Cont)

All specifications at +25°C, +V_{DD} = +V_{CC} = PV_{CC} = +5V, f_S = 44.1kHz, SYSCLK = 384f_S, 16-bit data, unless otherwise noted.

PARAMETER	CONDITIONS	PCM1719E			UNITS
		MIN	TYP	MAX	
FILTER PERFORMANCE					
Digital Filter					
Passband				0.445	f _S
Stopband		0.555			f _S
Passband Ripple				±0.17	dB
Stopband Attenuation		-35			dB
De-emphasis Error		-0.2		+0.55	dB
Delay Time	f _S = 32kHz to 48kHz		11.125/f _S		sec
ANALOG FILTER: Line Outputs					
Frequency Response	f = 20Hz to 20kHz		-0.16		dB
POWER SUPPLY REQUIREMENTS					
Voltage Range	V _{DD} , V _{CC} , PV _{CC}	+4.5	5.0	+5.5	VDC
Supply Current ⁽⁷⁾			18	25	mA
I _{CC} + I _{DD}	V _{DD} = V _{CC} = 5.0V		18	25	mA
I _{CC} (Full Scale Input)	PV _{CC} = 5.0V		20	25	mA
Power Dissipation					
P _D	V _{CC} , V _{DD} = 5.0		90	125	mW
P _{PD}	PV _{CC} = 5.0		90	125	mW
TEMPERATURE RANGE					
Operation		-25		+85	°C
Storage		-55		+100	°C

NOTES: (1) Dynamic performance specs are tested with external 20kHz low pass filter and THD-B specs are test with 30kHz LPF, 400Jz HPF, Average Mode, Shibasoku #725 THD Meter. (2) RSTB pin, MD pin, MC pin, and ML pin include an internal pull-up resistor. (3) RSTB pin, MD pin, MC pin, and ML pin include internal Schmitt trigger circuits. (4) ZERO pin is an open drain output. (5) Line output should be connected by a coupling capacitor. (6) Headphone output should be connected by a coupling capacitor. (7) Supply current and power dissipation are measured at CLK0 pin = no load, XTO pin = no load.

ABSOLUTE MAXIMUM RATINGS

Power Supply Voltage	
+V _{DD}	+6.5V
+V _{CC}	+6.5V
+PV _{CC}	+6.5V
-V _{DD} to +V _{CC} Δ	0.1V
+V _{DD} to +PV _{CC} Δ	0.1V
+V _{DD} to +PV _{CC} Δ	0.1V
Input Logic Voltage	-0.6V to (V _{DD} + 06V)
Power Dissipation	200mW
Operating Temperature Range	-25°C to +85°C
Storage Temperature	-55°C to +125°C
Lead Temperature (soldering, 5s)	+260°C
Junction Temperature, θ _{JA}	+130°C/W

PACKAGE INFORMATION

PRODUCT	PACKAGE	PACKAGE DRAWING NUMBER ⁽¹⁾
PCM1719E	28-Pin SSOP	324

NOTE: (1) For detailed drawing and dimension table, please see end of data sheet, or Appendix C of Burr-Brown IC Data Book.

PIN CONFIGURATION

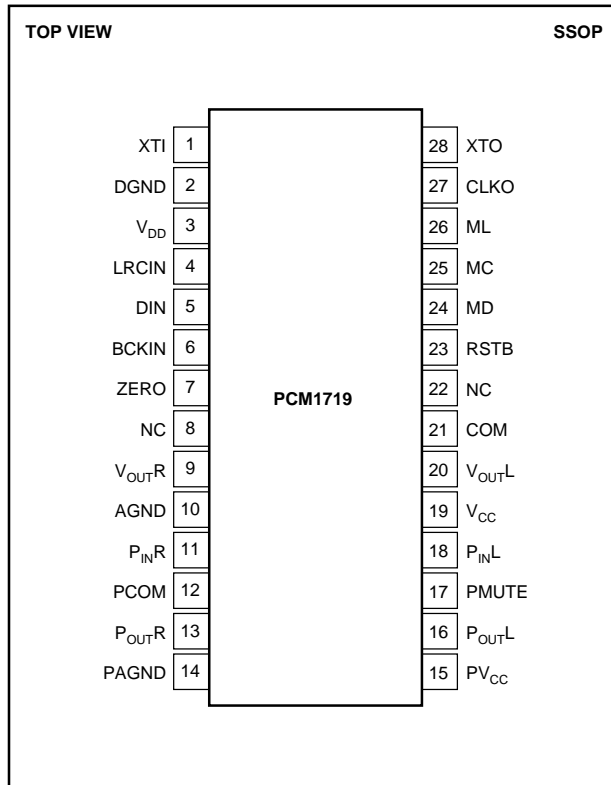

PIN ASSIGNMENTS

PIN	NAME	TYPE	FUNCTION
1	XTI	IN	Crystal Oscillator Input.
2	DGND	PWR	Digital Ground.
3	V _{DD}	PWR	+5V Digital Power Supply.
4 ⁽¹⁾	LRCIN	IN	Left/Right Word Clock. Frequency is equal to f _s .
5	DIN	IN	Serial Audio Data Input.
6	BCKIN	IN	Bit Clock for Loading in Audio Data.
7	ZERO	OUT	Zero Data Flag. This pin is "LOW" when the input data is continuously zero for 65, 536 periods of BCKIN.
8	NC	—	No Connection.
9	V _{OUTR}	OUT	Right-Channel Analog Line Output.
10	AGND	PWR	Analog Ground.
11	P _{INR}	IN	Input for Headphone Amplifier, Right-Channel.
12	PCOM	PWR	Headphone Amplifier Common. Bypass with 100μF.
13	P _{OUTR}	OUT	Right-Channel Headphone Amplifier Output.
14	PAGND	PWR	Headphone Amplifier Ground.
15	PVCC	PWR	+5V Headphone Amplifier Power Supply.
16	P _{OUTL}	OUT	Left-Channel Headphone Amplifier Output.
17 ⁽¹⁾	PMUTE	IN	Mute Control for Headphone Amplifier.
18	P _{INL}	IN	Input for Headphone Amplifier, Left-Channel.
19	V _{CC}	PWR	+5V Analog Power Supply.
20	V _{OUTL}	OUT	Left-Channel Analog Line Output.
21	COM	PWR	Line Out Common. Bypass with 10μF.
22	NC	—	No Connection.
23 ⁽¹⁾	RSTB	IN	External Reset Control.
24 ⁽¹⁾	MD	IN	Data for Serial Control.
25 ⁽¹⁾	MC	IN	Clock for Serial Control.
26 ⁽¹⁾	ML	IN	Latch for Serial Control.
27	CLKO	OUT	System Clock (256f _s or 384f _s) Output.
28	XTO	OUT	Crystal Oscillator Output.

NOTE: (1) With internal pull-up.

TYPICAL PERFORMANCE CURVES

At $T_A = +25^\circ\text{C}$, $V_{CC} = V_{DD} = PV_{CC} = +5\text{V}$, $R_L = 32\Omega + 32\Omega$, and $f = 1\text{kHz}$, $384f_s$, unless otherwise noted.

ANALOG PERFORMANCE

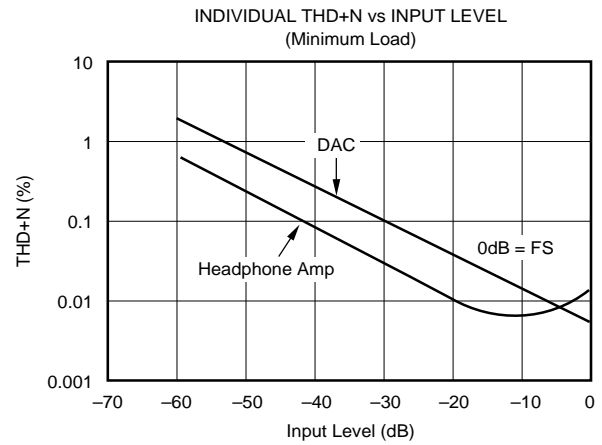
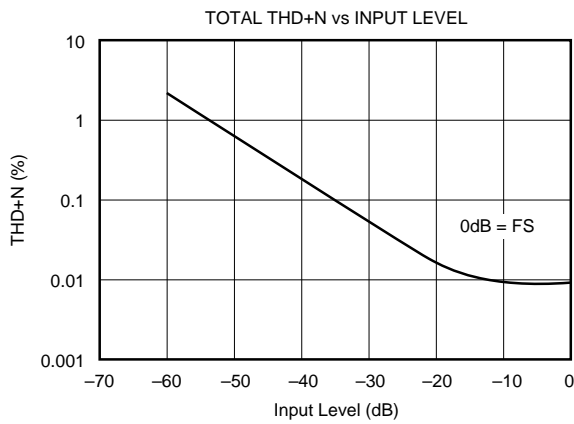
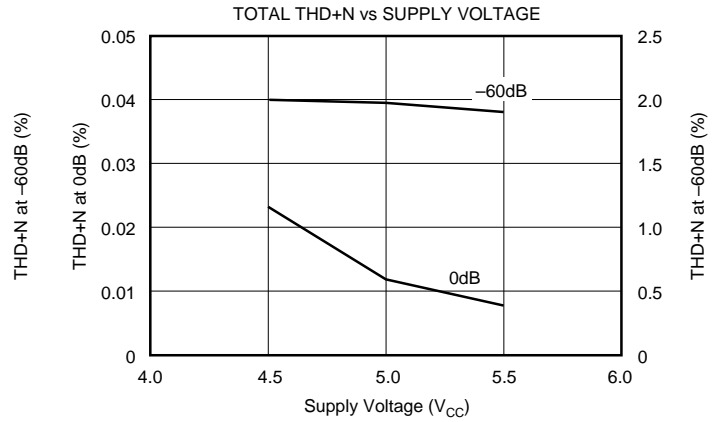
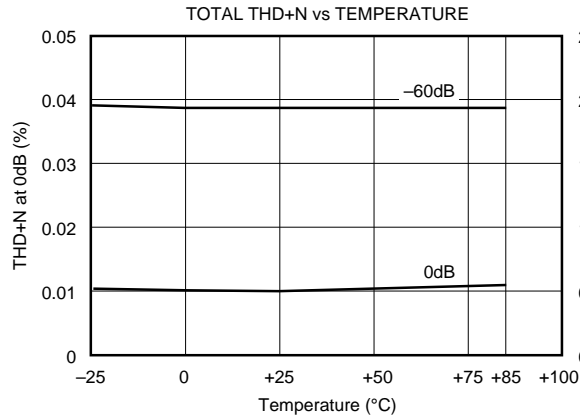

TYPICAL PERFORMANCE CURVES

At $T_A = +25^\circ\text{C}$, $V_{CC} = V_{DD} = PV_{CC} = +5\text{V}$, $R_L = 64\Omega$, $f_{SYS} = 384f_s$, and 16-bit input data, unless otherwise noted.

DIGITAL FILTER

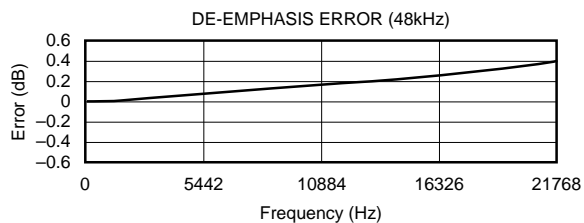
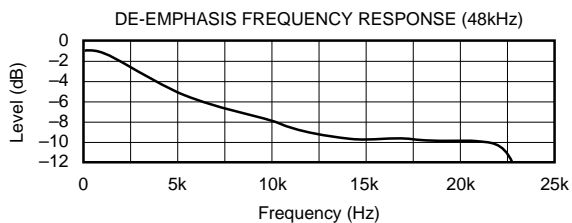
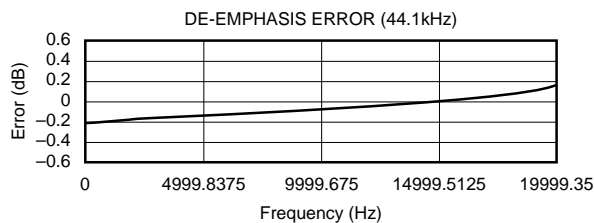
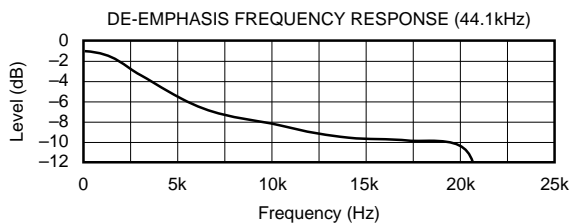
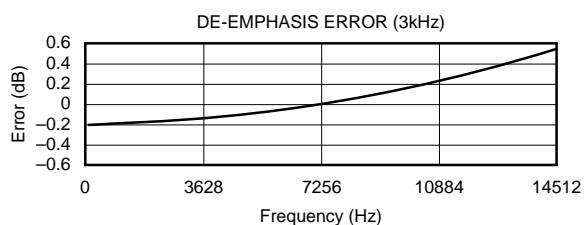
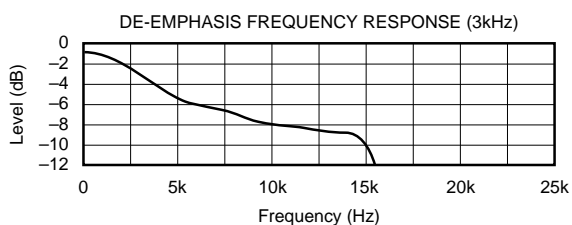
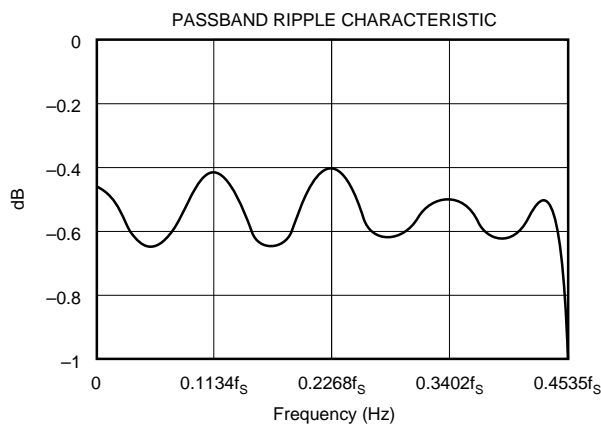
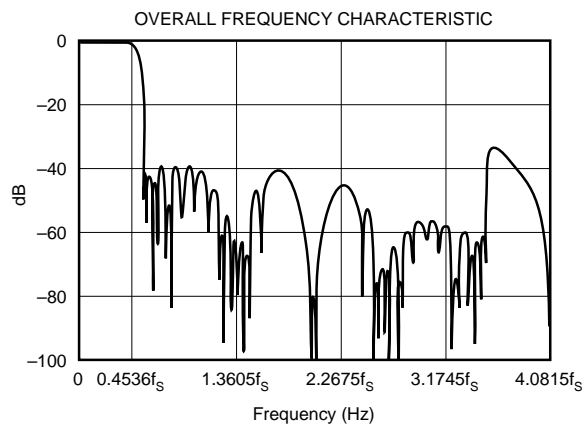

SYSTEM CLOCK

The system clock of PCM1719 must be either $256f_s$ or $384f_s$, where f_s is the audio sampling frequency, such as 32kHz, 44.1kHz, and 48kHz. The system clock is used to operate the digital filter and the multi-level delta-sigma modulator. The system clock can be either a crystal oscillator placed across XTI (pin 1) and XTO (pin28), or an external clock input to the XTI pin directly. In this case, the XTO pin should be open (floating). Figure 1 illustrates the internal clock circuit and typical connection.

The PCM1719 has a system clock detection circuit which automatically detects the system clock of either $256f_s$ or $384f_s$. The system clock should be synchronized with the LRCIN (pin 4) clock (sampling frequency), but the PCM1719 allows for a phase difference between LRCIN and the system clock. If the phase difference between LRCIN and system clock is larger than ± 6 bit clocks (BCKIN), the synchronization of the system clock and LRCIN is done

automatically. The analog outputs are forced to $V_{CC}/2$ during the synchronization operation. Table I shows the system clock frequency input to the PCM1719.

SAMPLING RATE FREQUENCY (LRCIN)	SYSTEM CLOCK FREQUENCY (MHz)	
	$256f_s$	$384f_s$
32kHz	8.1920	12.2880
44.1kHz	11.2896	16.9340
48kHz	12.2880	18.4320

TABLE I. System Clock Frequencies vs Sampling Rate.

INFINITE ZERO FLAG FUNCTION

When the audio input data (at both channels) is continuously zero (BPZ code) for 65, 536 cycles of bit clock (BCKIN), ZERO (pin 7) goes to a "LOW" level. When the audio input data is non-zero, the ZERO pin goes to a high-impedance state immediately. This pin is open-drain.

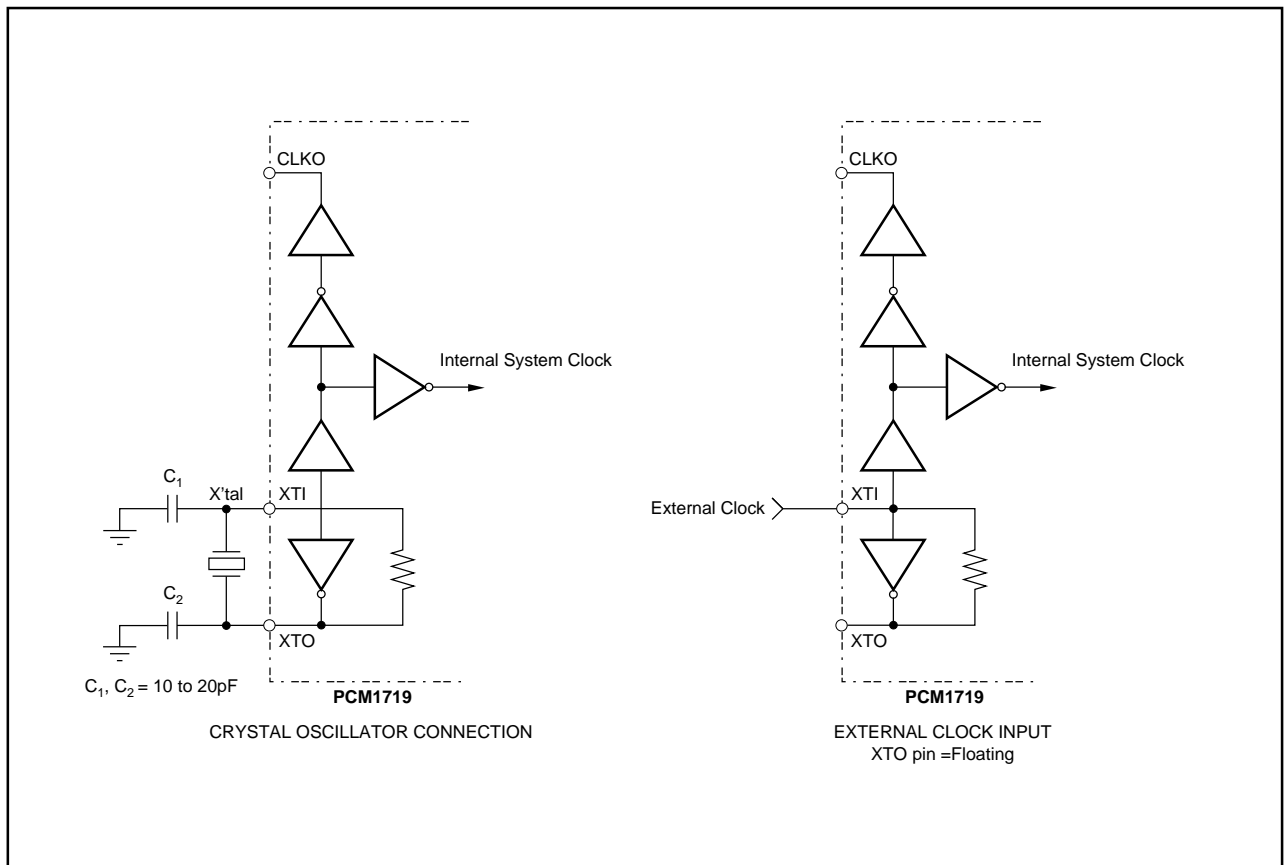

FIGURE 1. Internal Clock Circuit Diagram and Oscillator Connection.

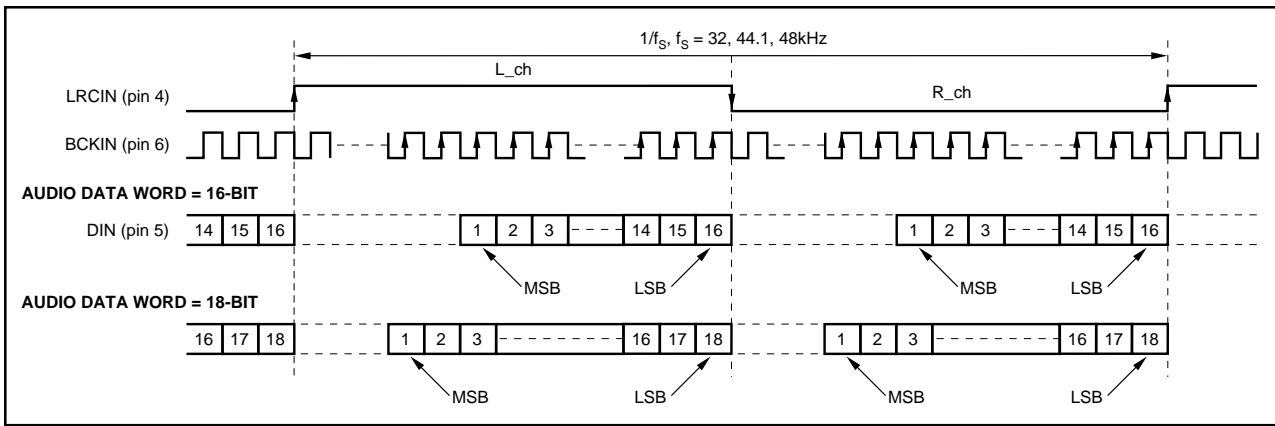

FIGURE 2. Data Input Timing of Normal Format (MSB-first, right-justified); Lch = “H”, Rch = “L”.

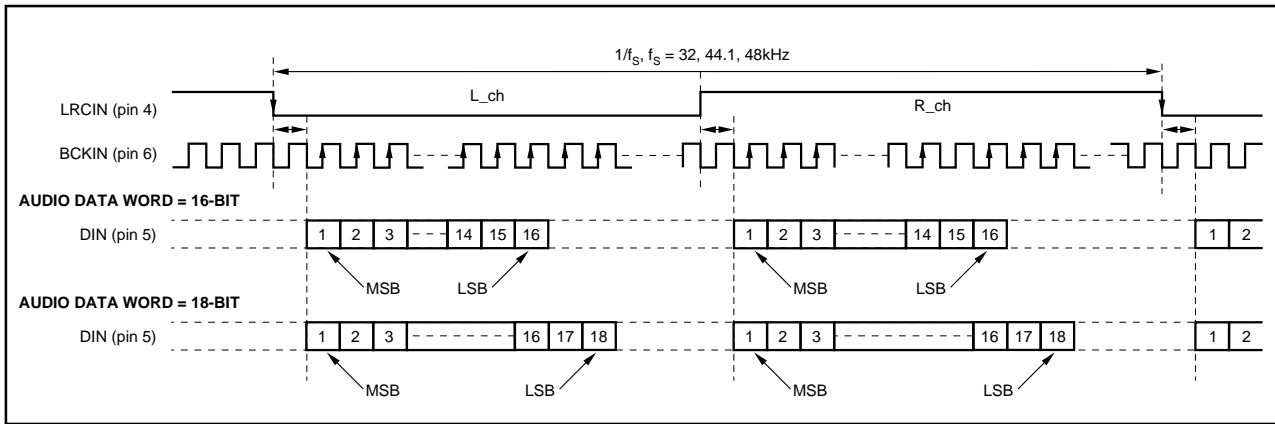

FIGURE 3. Data Input Timing of I²S Data Format (Philips format); Lch = “L”, Rch = “H”.

PCM AUDIO INTERFACE

PCM audio data of the PCM1719 is accepted via LRCIN (pin 4), DIN (pin 5) and BCKIN (pin 6). The PCM1719E accepts both normal and I²S data input formats. The normal data format is MSB-first, Two’s Complement and right-justified. The I²S format is compatible with Philips’ serial data protocol. In these formats, the serial data is 16- or 18-bit input selectable. Figures 2 and 3 illustrate the input audio data timing and format.

OPERATIONAL CONTROL

The Software Mode uses a three-wire interface on pins 24, 25 and 26. Pin 25 (MC) is used to clock in the serial control data, pin 26 (ML) is used to latch the serial control data, and pin 24 (MD) is used to load in the serial control register. There are four distinct registers, with bits 9 and 10 (of 16) determining which register is in use.

REGISTER CONTROL (Bits 9, 10)

REGISTER	B9 (A0)	B10 (A1)
0	0	0
1	1	0
2	0	1
3	1	1

Control data timing is shown in Figure 7. ML is used to latch the data from the control registers. After each register’s contents are checked in, ML should be taken “LOW” to latch in the data. A “res” in the register indicates that location is reserved for factory use. When loading the registers, the “res” bits should be set “LOW”.

REGISTER 0

B15	B14	B13	B12	B11	B10	B9	B8	B7	B6	B5	B4	B3	B2	B1	B0
res	res	res	res	res	A1	A0	LDL	AL7	AL6	AL5	AL4	AL3	AL2	AL1	AL0

Register 0 is used to control left channel attenuation. Bits 0-7 (AL0-AL7) are used to determine the attenuation level. The level of attenuation is given by:

$$ATT = [20\log_{10} (ATT_DATA/255)] \text{ dB}$$

ATTENUATION DATA LOAD CONTROL, LCH

Bit 8 (LDL) is used to simultaneously set analog outputs of Lch and Rch. An output level is controlled by AL[0:7] attenuation data when this bit is set to 1. When set to 0, an output level is not controlled and remained at the previous attenuation level. A LDR bit in Register 1 has an equivalent function as the LDL. When one of LDL or LDR is set to 1, the output level of the left and right channel is simultaneously controlled. The attenuation level is given by:

$$ATT = 20 \log(y/256) \text{ (dB)}, \text{ where } y = x, \text{ when } 0 \leq x \leq 254$$

$$y = x + 1, \text{ when } x = 255$$

X is the user-determined step number, an integer value between 0 and 255.

Example:

let $x = 255$

$$ATT = 20 \log\left(\frac{255+1}{256}\right) = 0\text{dB}$$

let $x = 254$

$$ATT = 20 \log\left(\frac{254}{256}\right) = -0.068\text{dB}$$

let $x = 1$

$$ATT = 20 \log\left(\frac{1}{256}\right) = -48.16\text{dB}$$

let $x = 0$

$$ATT = 20 \log\left(\frac{0}{256}\right) = -\infty$$

REGISTER 1

Register 1 is used to control right channel attenuation. As in Register 1, bits 0-7 (AR0-AR7) control the level of attenuation.

B15	B14	B13	B12	B11	B10	B9	B8	B7	B6	B5	B4	B3	B2	B1	B0
res	res	res	res	res	A1	A0	LDR	AR7	AR6	AR5	AR4	AR3	AR2	AR1	AR0

REGISTER 2

B15	B14	B13	B12	B11	B10	B9	B8	B7	B6	B5	B4	B3	B2	B1	B0
res	res	res	res	res	A1	A0	res	res	res	res	IZD	OPE	DM1	DM0	MUTE

Register 2 is used to control soft mute, digital de-emphasis, disable, and infinite zero detect. Bit 0 is used for soft mute; a HIGH level on bit 0 will cause the output to be muted. Bits 1 and 2 are used to control digital de-emphasis as shown below:

BIT 1 (DM0)	BIT 2 (DM1)	DE-EMPHASIS
0	0	De-emphasis disabled
1	0	De-emphasis enabled at 48kHz
0	1	De-emphasis enabled at 44.1kHz
1	1	De-emphasis enabled at 32kHz

Bits 3 (OPE) and 4 (IZD) are used to control the infinite zero detection features. Tables II through IV illustrate the relationship between IZD, OPE, and RSTB (reset control):

	DATA INPUT	DAC OUTPUT
IZD = 1	Zero	Forced to BPZ ⁽¹⁾
	Other	Normal
IZD = 0	Zero	Zero ⁽²⁾
	Other	Normal

TABLE II. Infinite Zero Detection (IZD) Function.

	DATA INPUT	DAC OUTPUT	SOFTWARE MODE INPUT
OPE = 1	Zero	Forced to BPZ ⁽¹⁾	Enabled
	Other	Forced to BPZ ⁽¹⁾	Enabled
OPE = 0	Zero	Controlled by IZD	Enabled
	Other	Normal	Enabled

TABLE III. Output Enable (OPE) Function.

	DATA INPUT	DAC OUTPUT	SOFTWARE MODE INPUT
RSTB = "HIGH"	Zero	Controlled by OPE and IZD	Enabled
	Other	Controlled by OPE and IZD	Enabled
RSTB = "LOW"	Zero	Forced to BPZ ⁽¹⁾	Disabled
	Other	Forced to BPZ ⁽¹⁾	Disabled

TABLE IV. Reset (RSTB) Function.

NOTE: (1) $\Delta\Sigma$ is disconnected from output amplifier. (2) $\Delta\Sigma$ is connected to output amplifier.

OPE controls the operation of the DAC: when OPE is "LOW", the DAC will convert all non-zero input data. If the input data is continuously zero for 65,536 cycles of BCKIN, the output will only be forced to zero only if IZD is "HIGH". When OPE is "HIGH", the output of the DAC will be forced to bipolar zero, irrespective of any input data.

IZD controls the operation of the zero detect feature: when IZD is "LOW", the zero detect circuit is off. Under this condition, no automatic muting will occur if the input is continuously zero. When IZD is "HIGH", the zero detect feature is enabled. If the input data is continuously zero for 65,536 cycles of BCKIN, the output will be immediately forced to a bipolar zero state ($V_{CC}/2$). The zero detection feature is used to avoid noise which may occur when the input is DC. When the output is forced to bipolar zero, there may be an audible click. PCM1719 allows the zero detect feature to be disabled so the user can implement an external muting circuit.

REGISTER 3

B15	B14	B13	B12	B11	B10	B9	B8	B7	B6	B5	B4	B3	B2	B1	B0
res	res	res	res	res	A1	A0	res	PL3	PL2	PL1	PL0	ATC	IW	LRP	IIS

Register 3 is used to select the I/O data formats. Bit 0 (IIS) is used to control the input data format. If the input data source is normal (16- or 18-bit, MSB first, right-justified), set bit 0 "LOW". If the input format is I²S, set bit 0 "HIGH".

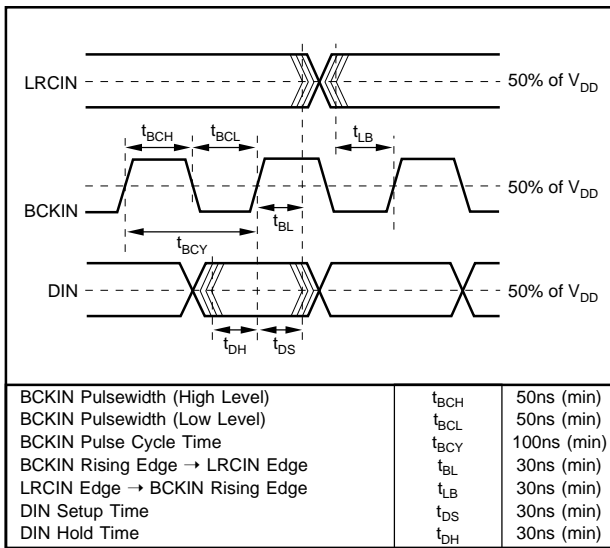

FIGURE 4. Data Input Timing.

Bit 1 is used to select the polarity of LRCIN (sample rate clock). When bit 1 is LOW, a HIGH state on LRCIN is used for the left channel, and a LOW state on LRCIN is used for the right channel. When bit 1 is HIGH the polarity of LRCIN is reversed.

Bit 2 is used to select the input word length. When bit 2 is LOW, the input word length is set for 16 bits; when bit 2 is HIGH, the input word length is set for 18 bits.

Bit 3 is used as an attenuation control. When bit 3 is set HIGH, the attenuation data on Register 0 is used for both channels, and the data in Register 1 is ignored. When bit 3 is LOW, each channel has separate attenuation data.

Bits 4 through 7 are used to determine the output format, as shown in Table V:

PL0	PL1	PL2	PL3	Lch OUTPUT	Rch OUTPUT	NOTE
0	0	0	0	MUTE	MUTE	MUTE
0	0	0	1	MUTE	R	
0	0	1	0	MUTE	L	
0	0	1	1	MUTE	(L + R)/2	
0	1	0	0	R	MUTE	
0	1	0	1	R	R	
0	1	1	0	R	L	REVERSE
0	1	1	1	R	(L + R)/2	
1	0	0	0	L	MUTE	
1	0	0	1	L	R	STEREO
1	0	1	0	L	L	
1	0	1	1	L	(L + R)/2	
1	1	0	0	(L + R)/2	MUTE	
1	1	0	1	(L + R)/2	R	
1	1	1	0	(L + R)/2	L	
1	1	1	1	(L + R)/2	(L + R)/2	MONO

TABLE V. PCM1719 Output Mode Control.

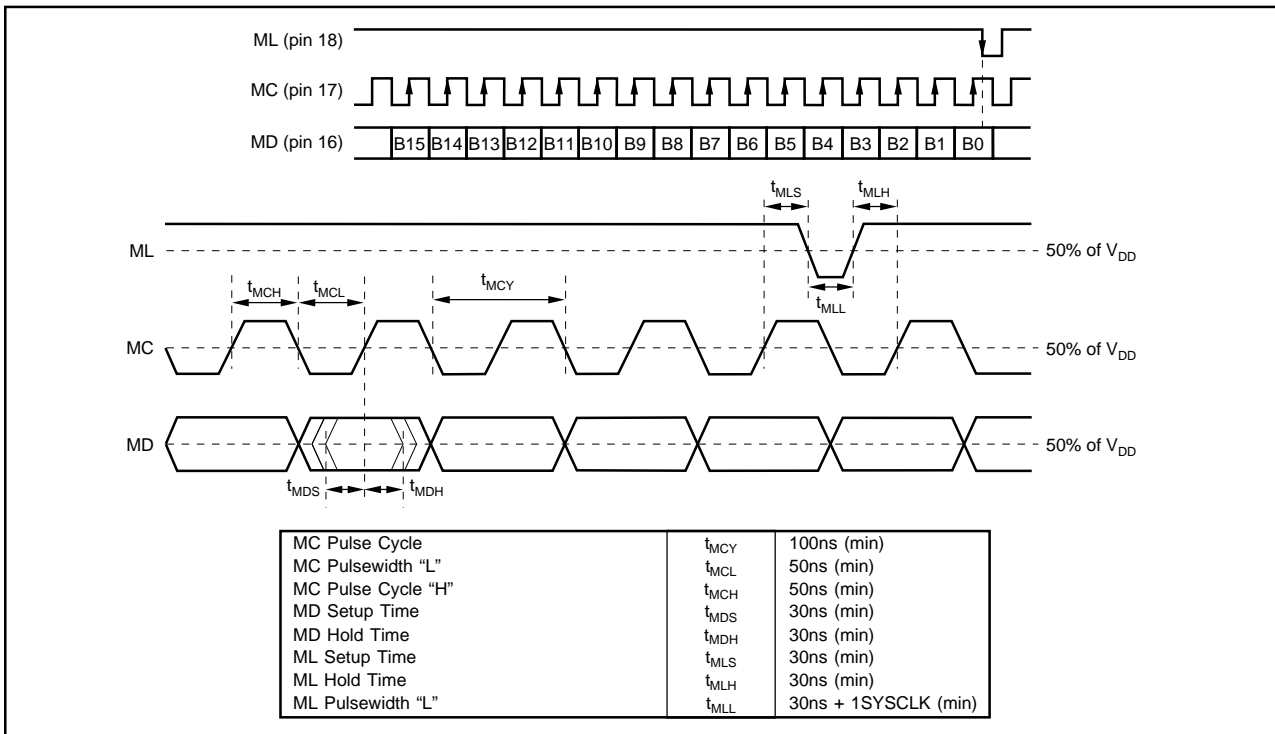

FIGURE 5. Control Data Timing in Software Mode Control.

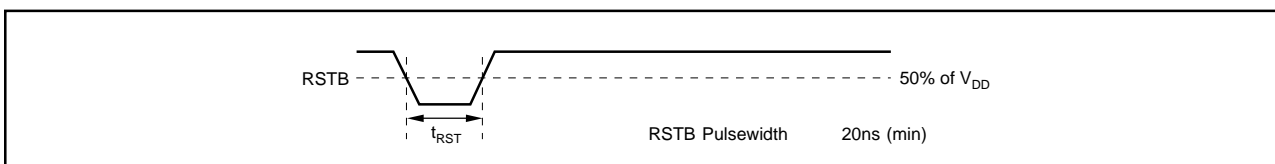

FIGURE 6. External Reset Timing.

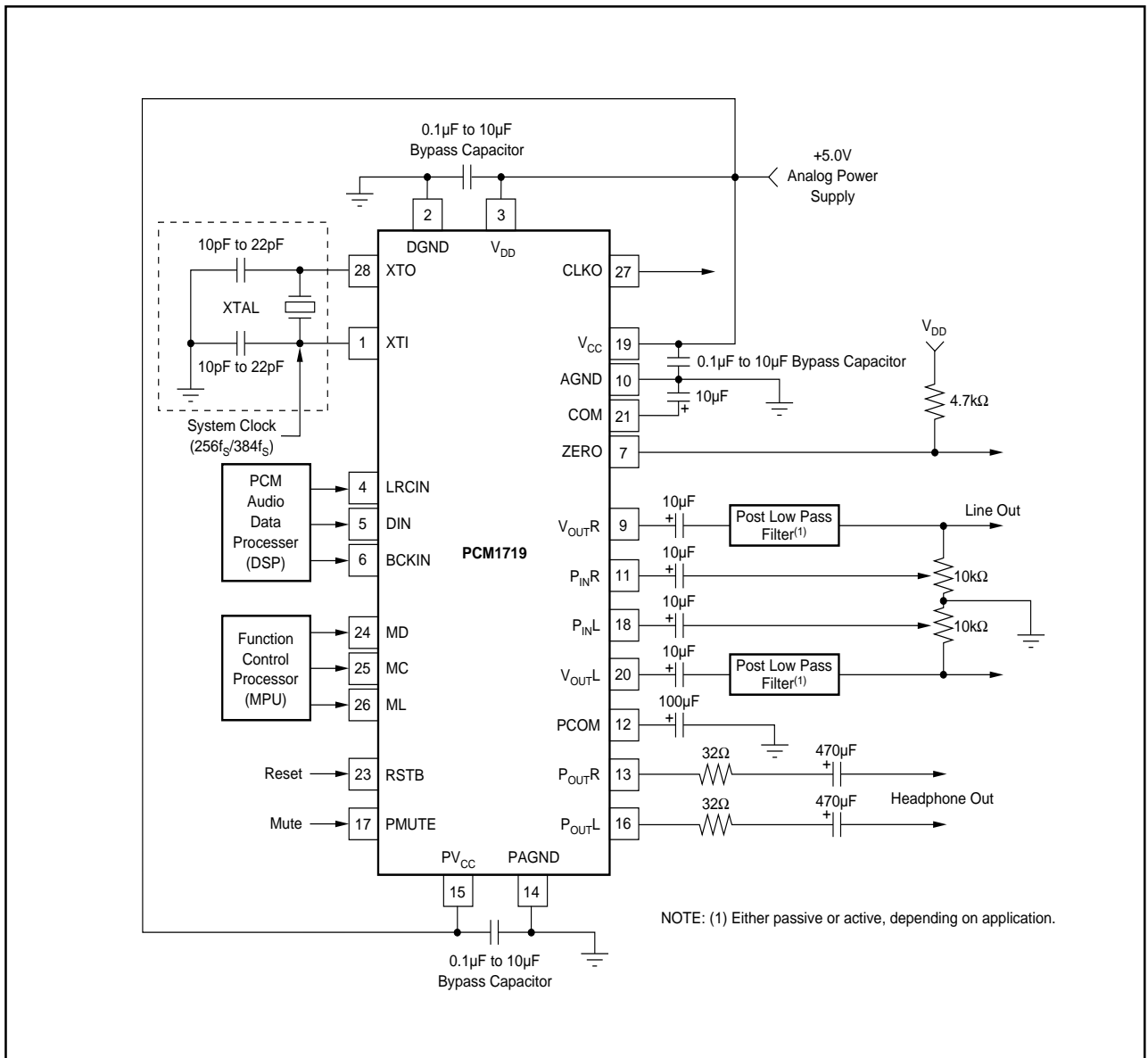

FIGURE 7. Typical Circuit Connection.

TYPICAL APPLICATION CIRCUIT

Figure 7 shows the typical application circuit. In this circuit, V_{DD} , V_{CC} , and PV_{CC} are connected to a common analog power supply. It is possible to use separate analog and digital power supplies for PCM1719. If separate supplies are used, the difference voltage between the supplies must be less than $\pm 0.1V$. PCM1719's headphone amplifier allows for high current flow from the outputs to ground. To keep the high load current from affecting the DAC's performance, the headphone jack ground should be connected to a low-impedance ground plane. Interference from the headphone amplifier can also be minimized by using a separate power supply for PV_{CC} , but avoid power supply deltas greater than $\pm 0.1V$.

Bypassing and decoupling capacitors should be placed as close as possible to the device pin. The capacitance between PCOM (pin 12) and/or COM (pin 21) to ground can be reduced to $1\mu F$, but this may decrease performance of the PCM1719's internal analog low-pass filter. The $10\mu F$ capacitor shown between COM and analog ground is used to set the pole for the PCM1719's internal low-pass filter. It is also important to limit the measurement bandwidth of the PCM1719 to 20kHz during performance evaluation. By definition, delta-sigma DACs have a large amount of energy beyond the audio band. Including this energy in THD+N measurements will not demonstrate the true in-band performance of PCM1719.

POWER SUPPLY CONNECTIONS

PCM1719 has two power supply connections: digital (V_{DD}) and analog (V_{CC}). Each connection also has a separate ground. If the power supplies turn on at different times, there is a possibility of a latch-up condition. To avoid this condition, it is recommended to have a common connection between the digital and analog power supplies. If separate supplies are used without a common connection, the delta between the two supplies during ramp-up time must be less than 0.6V.

An application circuit to avoid a latch-up condition is shown in Figure 8.

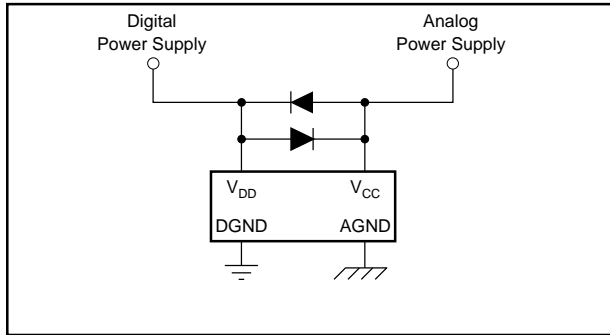

FIGURE 8. Latch-up Prevention Circuit.

THEORY OF OPERATION

The delta-sigma section of PCM1719 is based on a 5-level amplitude quantizer and a 3rd-order noise shaper. This section converts the oversampled input data to 5-level delta-sigma format.

A block diagram of the 5-level delta-sigma modulator is shown in Figure 9. This 5-level delta-sigma modulator has the advantage of stability and clock jitter sensitivity over the typical one-bit (2 level) delta-sigma modulator.

The combined oversampling rate of the delta-sigma modulator and the internal 8-times interpolation filter is $48f_s$ for a $384f_s$ system clock, and $64f_s$ for a $256f_s$ system clock. The theoretical quantization noise performance of the 5-level delta-sigma modulator is shown in Figure 10.

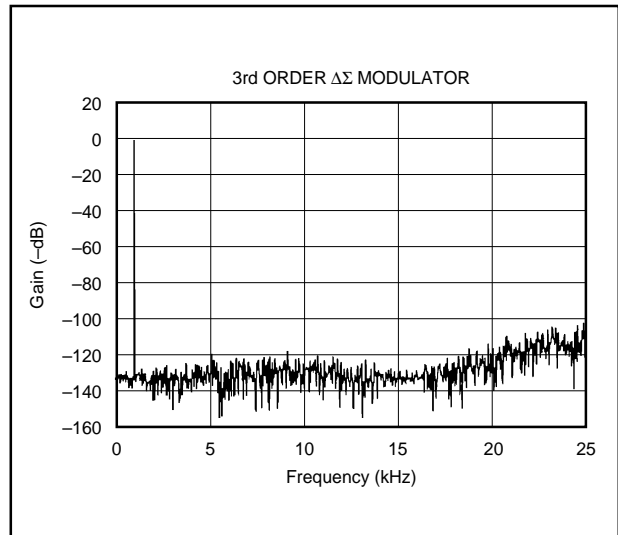

FIGURE 10. Quantization Noise Spectrum.

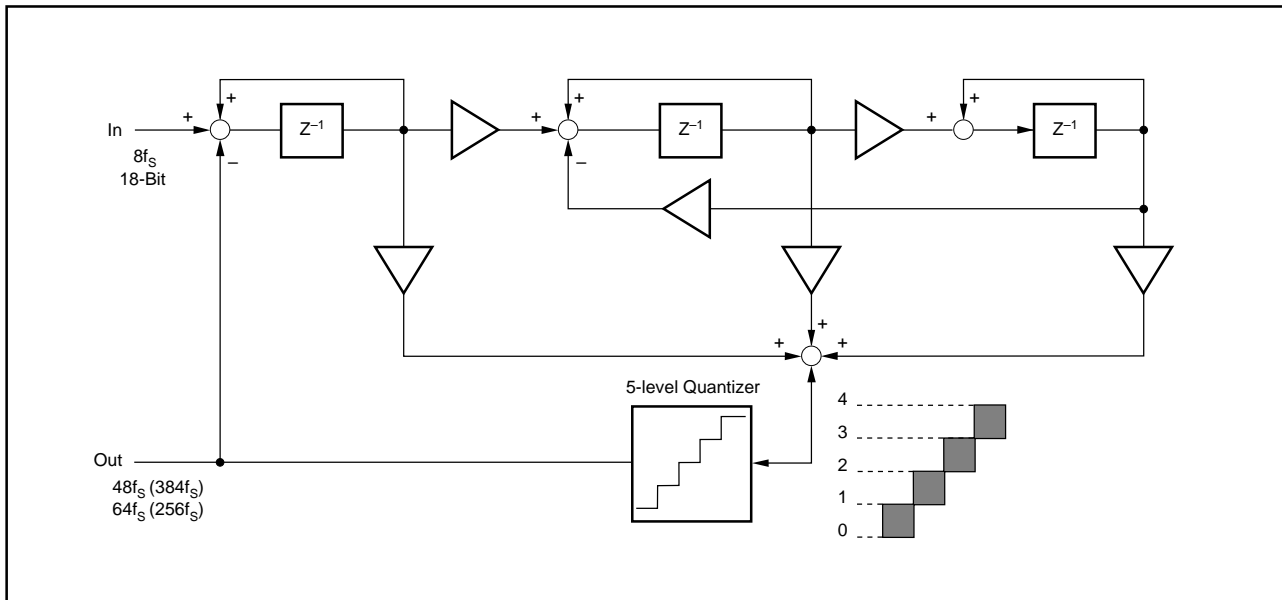

FIGURE 9. 5-Level $\Delta\Sigma$ Modulator Block Diagram.

APPLICATION CONSIDERATIONS

DELAY TIME

There is a finite delay time in delta-sigma converters. In A/D converters, this is commonly referred to as latency. For a delta-sigma D/A converter, delay time is determined by the order number of the FIR filter stage, and the chosen sampling rate. The following equation expresses the delay time of PCM1719:

$$T_D = 11.125 \times 1/f_S$$

For $f_S = 44.1\text{kHz}$, $T_D = 11.125/44.1\text{kHz} = 502.8\mu\text{s}$

Applications using data from a disc or tape source, such as CD audio, CD-Interactive, Video CD, DAT, Minidisc, etc., generally are not affected by delay time. For some professional applications such as broadcast audio for studios, it is important for total delay time to be less than 2ms.

INTERNAL RESET

When power is first applied to PCM1719, an automatic reset function occurs after 1,024 cycles of XTI clock. Refer to Table I for default conditions. During the first 1,024 cycles of XTI clock, PCM1719 cannot be programmed (Software Control). Data can be loaded into the control registers during this time, and after 1,204 cycles of XTI clock, a "LOW" on ML (pin 18) will initiate programming.

OUTPUT FILTERING

For testing purposes all dynamic tests are done on the PCM1719 using a 20kHz low pass filter. This filter limits the measured bandwidth for THD+N, etc. to 20kHz. Failure to use such a filter will result in higher THD+N and lower SNR and Dynamic Range readings than are found in the specifications. The low pass filter removes out-of-band noise. Although it is not audible, it may affect dynamic specification numbers.

The performance of the internal low pass filter from DC to 24kHz is shown in Figure 11. The higher frequency rolloff of the filter is shown in Figure 12. If the user's application has the PCM1719 driving a wideband amplifier, it is recommended to use an external low pass filter. A simple 3rd-order filter is shown in Figure 13. For some applications, a passive RC filter or 2nd-order filter may be adequate.

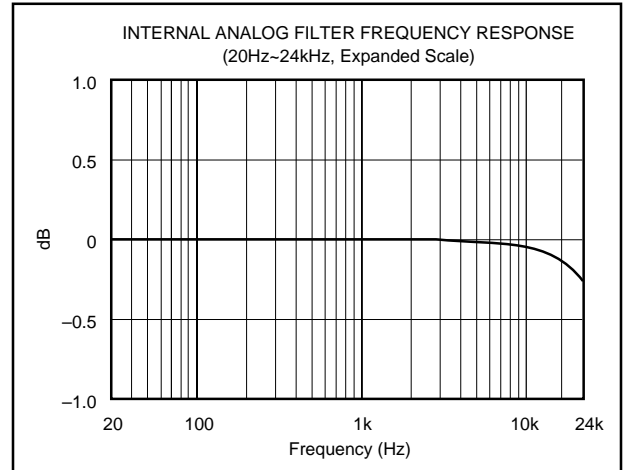

FIGURE 11. Low Pass Filter Frequency Response.

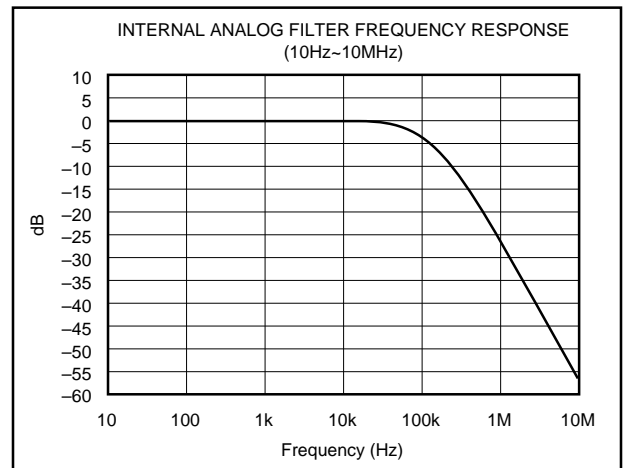

FIGURE 12. Low Pass Filter Frequency Response.

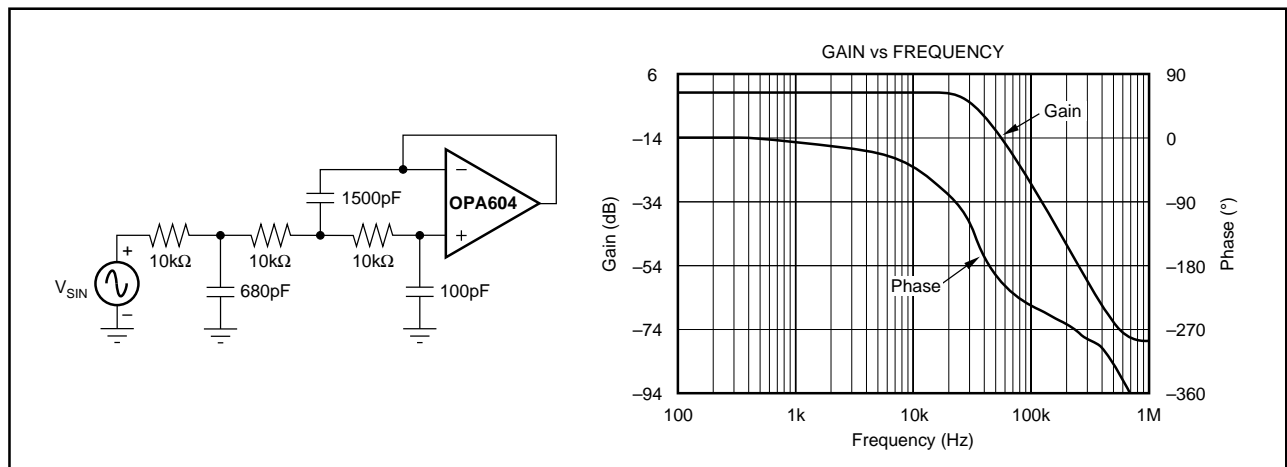

FIGURE 13. 3rd-Order LPF.

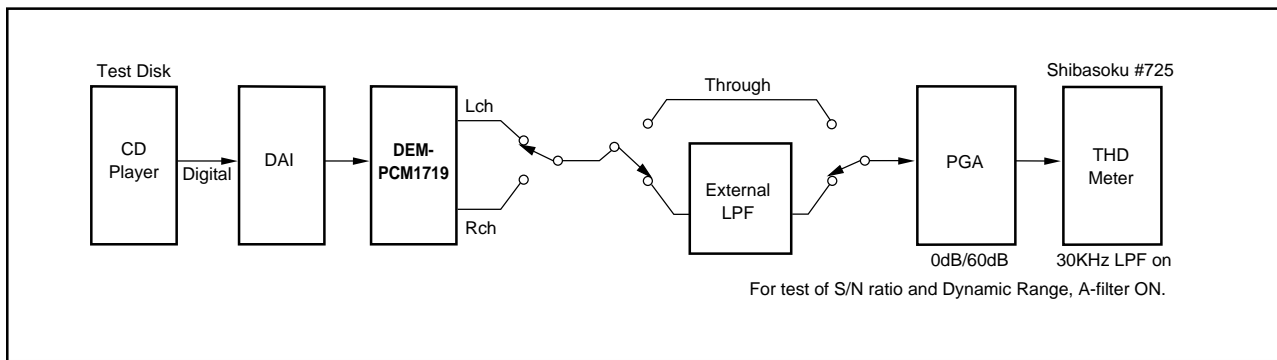

FIGURE 14. Test Block Diagram.

TEST CONDITIONS

Figure 14 illustrates the actual test conditions applied to PCM1719 in production. The external filter is necessary in the production environment for the removal of noise resulting from the relatively long physical distance between the unit and the test analyzer. In most actual applications, the 3rd-order filter shown in Figure 13 is adequate. Under normal conditions, THD+N typical performance is -70dB with a 30kHz low pass filter (shown here on the THD meter), improving to -89dB when the external 20kHz 11th-order filter is used.

JITTER SENSITIVITY

Delta-sigma DACs are by nature very sensitive to jitter on the master clock. Phase noise on the clock will result in an increase in noise, ultimately degrading dynamic range. It is difficult to quantify the effect of jitter due to problems in synthesizing low levels of jitter. One of the reasons delta-sigma DACs are prone to jitter sensitivity is the large quantization noise when the modulator can only achieve two discrete output levels (0 or 1). The multi-level delta-sigma DAC has improved theoretical SNR because of multiple output states. This reduces sensitivity to jitter. Figure 15 contrasts jitter sensitivity between a one-bit PWM type DAC and multi-level delta-sigma DAC. The data was derived using a simulator, where clock jitter could be completely synthesized.

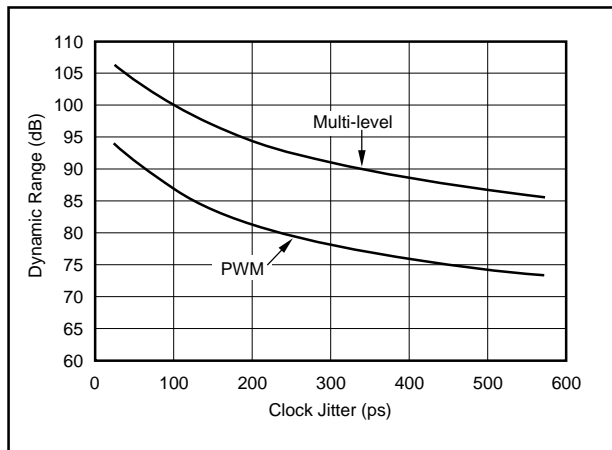

FIGURE 15. Simulation Results of Clock Jitter Sensitivity.

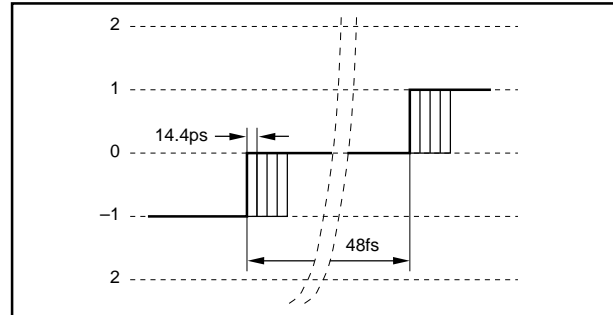

FIGURE 16. Simulation Method for Clock Jitter.

HEADPHONE AMPLIFIER

PCM1719 has an integrated headphone amplifier which can directly drive a 32Ω load, such as headphones. The amplifier is configured in a gain of -2.8dB (inverting), and the maximum output current is 12.5mA (rms). The maximum output voltage is 0.8Vrms into a 64Ω load (stereo 32Ω headphones), based on the typical DAC full scale output of 3.1V (p-p). P_{INL} and P_{INR} should be AC-coupled such that the input impedance for the headphone amplifier is $55\text{k}\Omega$ typical, and the noninverting input is biased to $V_{CC}/2$.

The headphone amplifier has no internal current limiting circuit. It is recommended to use an external current limiting resistor to avoid damage caused by overloading the output, and avoid shorting P_{OUTL} and P_{OUTR} to ground. The minimum output load of 64Ω includes any current limiting resistor. If the input impedance of the headphone is 32Ω , a current limiting resistor of 32Ω should be used. Figure 17

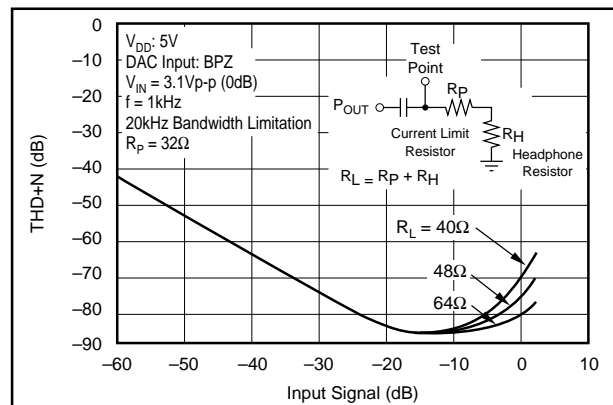

FIGURE 17. THD+N vs Input Signal, Output Load.

illustrates THD+N versus input signal and output load. The PCM1719 headphone amplifier specification for THD+N is done with a 64Ω load at 12.5mA (rms) maximum output current. Although PCM1719 is capable of driving loads as low as 15Ω , the output waveform will be saturated under such a condition. The recommended application circuit employs a 32Ω load with a 32Ω current limiting resistor.

VOLUME CONTROL

PCM1719 allows the user to attenuate the volume by using a variable resistor. In the actual application, a $10k\Omega$ pot is connected between the line (DAC) outputs and analog ground,

with the center tap of the pot AC-coupled to the headphone amplifier's inputs. Refer to Figure 7, the typical connection diagram, for an illustration of this circuit.

ANALOG MUTE FUNCTION

The headphone amplifier's output can be muted to -80dB . When PMUTE is taken "LOW", the headphone outputs are muted. For normal operation, PMUTE should be held "HIGH" or left open.

PACKAGING INFORMATION

ORDERABLE DEVICE	STATUS(1)	PACKAGE TYPE	PACKAGE DRAWING	PINS	PACKAGE QTY
PCM1719E	ACTIVE	SSOP	DB	28	47
PCM1719E/2K	ACTIVE	SSOP	DB	28	2000

(1) The marketing status values are defined as follows:

ACTIVE: Product device recommended for new designs.

LIFEBUY: TI has announced that the device will be discontinued, and a lifetime-buy period is in effect.

NRND: Not recommended for new designs. Device is in production to support existing customers, but TI does not recommend using this part in a new design.

PREVIEW: Device has been announced but is not in production. Samples may or may not be available.

OBSOLETE: TI has discontinued the production of the device.

IMPORTANT NOTICE

Texas Instruments Incorporated and its subsidiaries (TI) reserve the right to make corrections, modifications, enhancements, improvements, and other changes to its products and services at any time and to discontinue any product or service without notice. Customers should obtain the latest relevant information before placing orders and should verify that such information is current and complete. All products are sold subject to TI's terms and conditions of sale supplied at the time of order acknowledgment.

TI warrants performance of its hardware products to the specifications applicable at the time of sale in accordance with TI's standard warranty. Testing and other quality control techniques are used to the extent TI deems necessary to support this warranty. Except where mandated by government requirements, testing of all parameters of each product is not necessarily performed.

TI assumes no liability for applications assistance or customer product design. Customers are responsible for their products and applications using TI components. To minimize the risks associated with customer products and applications, customers should provide adequate design and operating safeguards.

TI does not warrant or represent that any license, either express or implied, is granted under any TI patent right, copyright, mask work right, or other TI intellectual property right relating to any combination, machine, or process in which TI products or services are used. Information published by TI regarding third-party products or services does not constitute a license from TI to use such products or services or a warranty or endorsement thereof. Use of such information may require a license from a third party under the patents or other intellectual property of the third party, or a license from TI under the patents or other intellectual property of TI.

Reproduction of information in TI data books or data sheets is permissible only if reproduction is without alteration and is accompanied by all associated warranties, conditions, limitations, and notices. Reproduction of this information with alteration is an unfair and deceptive business practice. TI is not responsible or liable for such altered documentation.

Resale of TI products or services with statements different from or beyond the parameters stated by TI for that product or service voids all express and any implied warranties for the associated TI product or service and is an unfair and deceptive business practice. TI is not responsible or liable for any such statements.

Following are URLs where you can obtain information on other Texas Instruments products and application solutions:

Products		Applications	
Amplifiers	amplifier.ti.com	Audio	www.ti.com/audio
Data Converters	dataconverter.ti.com	Automotive	www.ti.com/automotive
DSP	dsp.ti.com	Broadband	www.ti.com/broadband
Interface	interface.ti.com	Digital Control	www.ti.com/digitalcontrol
Logic	logic.ti.com	Military	www.ti.com/military
Power Mgmt	power.ti.com	Optical Networking	www.ti.com/opticalnetwork
Microcontrollers	microcontroller.ti.com	Security	www.ti.com/security
		Telephony	www.ti.com/telephony
		Video & Imaging	www.ti.com/video
		Wireless	www.ti.com/wireless

Mailing Address: Texas Instruments
Post Office Box 655303 Dallas, Texas 75265

Copyright © 2003, Texas Instruments Incorporated