

阅读申明

- 1.本站收集的数据手册和产品资料都来自互联网，版权归原作者所有。如读者和版权方有任何异议请及时告之，我们将妥善解决。
- 2.本站提供的中文数据手册是英文数据手册的中文翻译，其目的是协助用户阅读，该译文无法自动跟随原稿更新，同时也可能存在翻译上的不当。建议读者以英文原稿为参考以便获得更精准的信息。
- 3.本站提供的产品资料，来自厂商的技术支持或者使用者的心得体会等，其内容可能存在描述上的差异，建议读者做出适当判断。
- 4.如需与我们联系，请发邮件到marketing@iczoom.com，主题请标有“数据手册”字样。

Read Statement

1. The datasheets and other product information on the site are all from network reference or other public materials, and the copyright belongs to the original author and original published source. If readers and copyright owners have any objections, please contact us and we will deal with it in a timely manner.
2. The Chinese datasheets provided on the website is a Chinese translation of the English datasheets. Its purpose is for reader's learning exchange only and do not involve commercial purposes. The translation cannot be automatically updated with the original manuscript, and there may also be improper translations. Readers are advised to use the English manuscript as a reference for more accurate information.
3. All product information provided on the website refer to solutions from manufacturers' technical support or users the contents may have differences in description, and readers are advised to take the original article as the standard.
4. If you have any questions, please contact us at marketing@iczoom.com and mark the subject with "Datasheets" .

Low voltage high bandwidth dual single-pole double-throw analog switch

Datasheet - production data

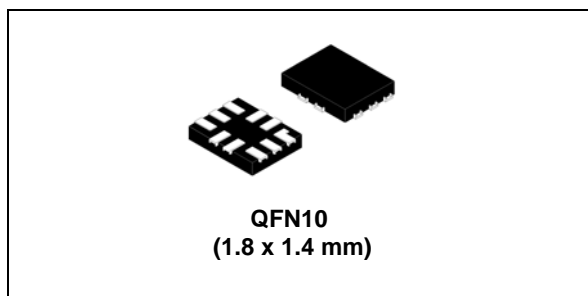

Features

- Ultra low power dissipation:
 - $I_{CC} = 1 \mu\text{A}$ (max.) at $T_A = 85^\circ\text{C}$
- Low “ON” resistance:
 - $R_{ON} = 4.8 \Omega$ ($T_A = 25^\circ\text{C}$) at $V_{CC} = 4.3 \text{ V}$
 - $R_{ON} = 5.9 \Omega$ ($T_A = 25^\circ\text{C}$) at $V_{CC} = 3.0 \text{ V}$
- Wide operating voltage range:
 - V_{CC} (opr.) = 1.65 V to 4.3 V
- 4.3 V tolerant and 1.8 V compatible threshold on digital control input at $V_{CC} = 2.3 \text{ V}$ to 3.0 V
- Typical bandwidth (-3 dB) at 800 MHz on all channels
- USB (2.0) high speed (480 Mbps) signal switching compliant
- Integrated fail safe function
- Interrupt function to indicate to the processor that the device is in dedicated port charging mode
- Latch-up performance exceeds 500 mA per JESD 78, Class II
- ESD performance exceeds JESD22:
 - Dn pins: 4000-V human body model (A114-A)
 - All other pins: 2000-V human body model (A114-A)

Applications

- Wearable
- Sport and fitness
- Portable equipment

Description

The AS21P2THB is a high-speed CMOS low voltage dual analog SPDT (single pole double throw) switch or 2:1 multiplexer/demultiplexer switch fabricated in silicon gate C²MOS technology. It is designed to operate from 1.65 V to 4.3 V, thus making this device the ideal selection for portable applications.

The SEL input is provided to control the switch. The switch nS1 is ON (connected to common ports Dn) when the SEL input is held high and OFF (high impedance state exists between the two ports) when SEL is held low, the switch nS2 is ON (it is connected to common port Dn) when the SEL input is held low and OFF (high impedance state exists between the two ports) when SEL is held high. AS21P2THB has an integrated fail safe function to withstand over-voltage condition when the device is powered off.

The AS21P2THB also has an interrupt pin which sends a signal to the processor when the device is in dedicated port charging mode. Additional key features are fast switching speed, break-before-make-delay time and ultralow power consumption. All inputs and outputs are equipped with protection circuits against static discharge, giving them ESD immunity and transient excess voltage.

Table 1. Device summary

Order code	Package	Packaging
AS21P2THB	QFN10 (1.8 x 1.4 mm)	Tape and reel

Contents

1	Pin settings	3
2	Logic diagram	4
3	Dedicated port charging detection	5
4	Maximum rating	6
	4.1 Recommended operating conditions	6
5	Electrical characteristics	7
6	Test circuit	12
7	Package mechanical data	17
8	Revision history	22

1 Pin settings

Figure 1. Pin connection (top through view)

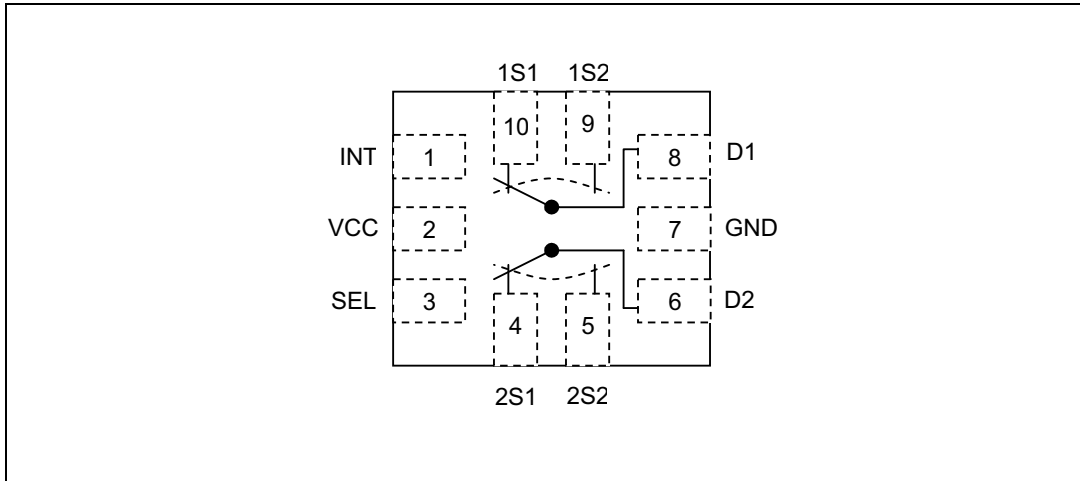

Table 2. Pin description

Pin number	Symbol	Name and function
1	INT	Interrupt
2	VCC	Positive supply voltage
3	SEL	Control
4	2S1	Independent channel for switch 2
5	2S2	Independent channel for switch 2
6	D2	Common channel for switch 2
7	GND	Ground (0 V)
8	D1	Common channel for switch 1
9	1S2	Independent channel for switch 1
10	1S1	Independent channel for switch 1

2 Logic diagram

Figure 2. Logic block diagram

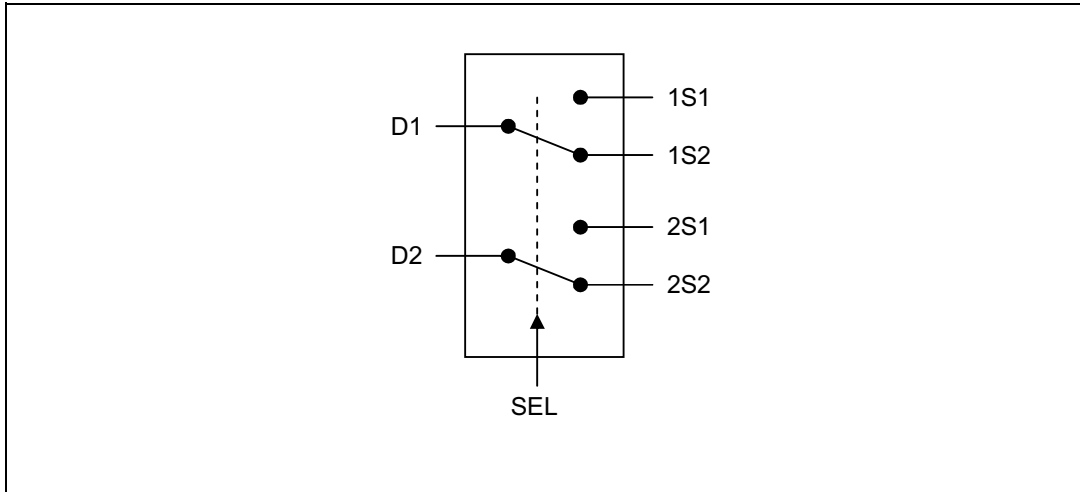

Figure 3. Logic equivalent circuit

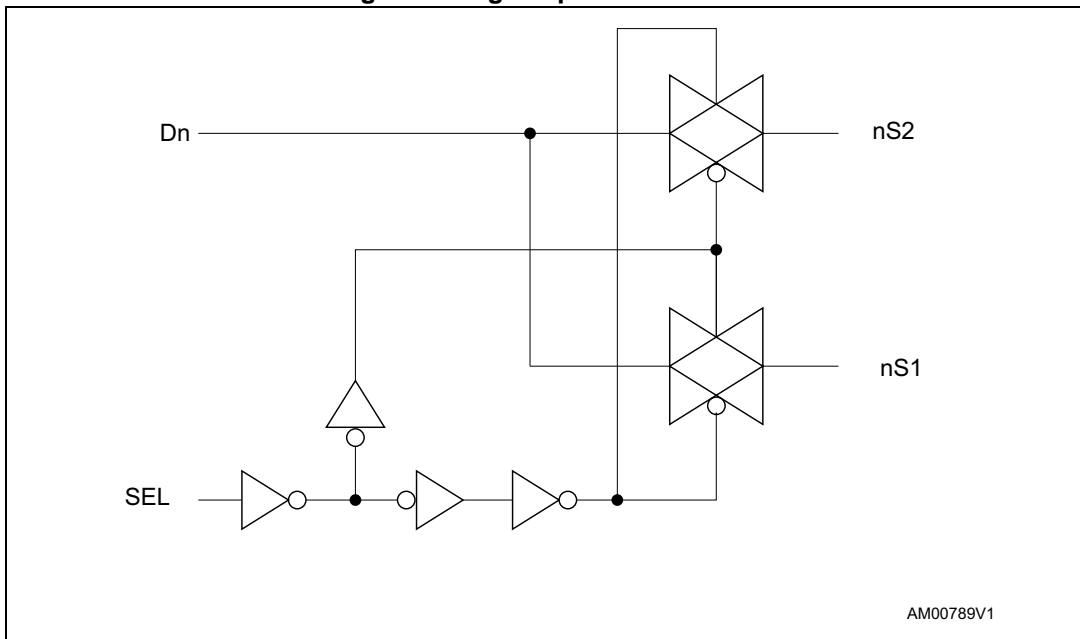

Table 3. Truth table

SEL	Switch nS1	Switch nS2
H	ON	OFF ⁽¹⁾
L	OFF ⁽¹⁾	ON

1. High impedance.

3 Dedicated port charging detection

The AS21P2THB has a built-in dedicated port charging detection circuit to detect the condition when the USB D+/D- lines are both in high state. When this occurs, the device sends an interrupt signal to the processor to indicate that the connected USB device is in dedicated port charging mode.

Figure 4. Interrupt function logic representation

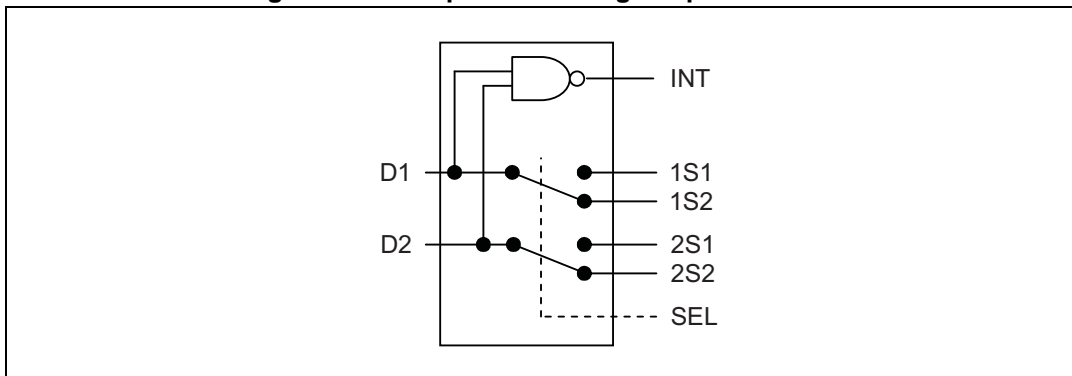

4 Maximum rating

Stressing the device above the rating listed in the “Absolute maximum ratings” table may cause permanent damage to the device. These are stress ratings only and operation of the device at these or any other conditions above those indicated in the operating sections of this specification is not implied. Exposure to absolute maximum rating conditions for extended periods may affect device reliability.

Table 4. Absolute maximum ratings

Symbol	Parameter	Value	Unit
V_{CC}	Supply voltage	-0.5 to 5.5	V
V_I	DC input voltage	-0.5 to $V_{CC} + 0.5$	V
V_{IC}	DC control input voltage	-0.5 to 5.5	V
V_O	DC output voltage	-0.5 to $V_{CC} + 0.5$	V
I_{IKC}	DC input diode current on control pin ($V_{SEL} < 0V$)	-50	mA
I_{IK}	DC input diode current ($V_{SEL} < 0V$)	± 50	mA
I_{OK}	DC output diode current	± 20	mA
I_O	DC output current	± 128	mA
I_{OP}	DC output current peak (pulse at 1ms, 10% duty cycle)	± 300	mA
I_{CC} or I_{GND}	DC V_{CC} or ground current	± 100	mA
P_D	Power dissipation at $T_A = 70\text{ °C}$ ⁽¹⁾	1120	mW
T_{stg}	Storage temperature	-65 to +150	°C
T_L	Lead temperature (10 sec)	300	°C

1. Derate above 70 °C by 18.5 mW/°C.

4.1 Recommended operating conditions

Table 5. Recommended operating conditions

Symbol	Parameter	Value	Unit
V_{CC}	Supply voltage	1.65 to 4.3	V
V_I	Input voltage	0 to V_{CC}	V
V_{IC}	Control input voltage	0 to 4.3	V
V_O	Output voltage	0 to V_{CC}	V
T_{op}	Operating temperature	-40 to 85	°C
dt/dv	Input rise and fall time control input	$V_L = 1.65\text{ V to }2.7\text{ V}$	0 to 20
		$V_L = 3.0\text{ to }4.3\text{ V}$	0 to 10

5 Electrical characteristics

Table 6. DC specifications

Symbol	Parameter	V _{CC} (V)	Test condition	Value					Unit
				T _A = 25 °C			-40 to 85 °C		
				Min	Typ	Max	Min	Max	
V _{IH}	High level input voltage	1.65 – 1.95	–	0.65 V _{CC}	–	–	0.65V _{CC}	–	V
		2.3 – 2.5		1.2	–	–	1.2	–	
		2.7 – 3.0		1.3	–	–	1.3	–	
		3.3 – 3.6		1.4	–	–	1.4	–	
		4.3		1.6	–	–	1.6	–	
V _{IL}	Low level input voltage	1.65 – 1.95	–	–	–	0.25	–	0.25	V
		2.3 – 2.5		–	–	0.25	–	0.25	
		2.7 – 3.0		–	–	0.25	–	0.25	
		3.3 – 3.6		–	–	0.30	–	0.30	
		4.3		–	–	0.40	–	0.40	
V _{IH-INT}	High level input voltage for INT	4.3	–	2.4	–	–	2.4	–	V
V _{IL-INT}	Low level input voltage for INT	4.3	–	–	–	0.9	–	0.9	V
V _{OL-INT}	Low level output voltage for INT	4.3	I _O = 4 mA	–	–	0.40	–	0.50	V
R _{PEAK}	Switch ON peak resistance	1.8	V _S = 0 V to V _{CC} I _S = 8 mA	–	15.1	17.8	–	–	Ω
		2.7		–	6.4	8.0	–	–	
		3.0		–	5.9	7.5	–	–	
		3.7		–	5.0	6.5	–	–	
		4.3		–	4.8	6.1	–	–	
R _{ON}	Switch ON resistance	3.0	V _S = 3 V I _S = 8 mA	–	4.2	5.4	–	–	Ω
		3.0	V _S = 0.4 V I _S = 8 mA	–	5.7	7.0	–	–	

Table 6. DC specifications (continued)

Symbol	Parameter	V _{CC} (V)	Test condition	Value					Unit
				T _A = 25 °C			-40 to 85 °C		
				Min	Typ	Max	Min	Max	
ΔR _{ON}	ON resistance match between channels ⁽¹⁾	1.8	V _S at R _{ON} max I _S = 8 mA	-	-	-	-	-	Ω
		2.7		-	-	-	-		
		3.0		-	0.1	-	-	-	
		3.7		-	-	-	-	-	
		4.3		-	-	-	-	-	
R _{FLAT}	ON resistance flatness ⁽²⁾	1.8	V _S = 0 V to 0.4 V I _S = 8 mA	-	4.5	-	-	-	Ω
		1.8	V _S = 0 V to V _{CC} I _S = 8 mA	-	9.0	-	-	-	
		2.7		-	2.2	-	-	-	
		3.0		-	1.8	-	-	-	
		3.7		-	1.6	-	-	-	
		4.3		-	1.6	-	-	-	
I _{OFF}	OFF state leakage current (Sn), (D)	4.3	V _S = 0.3 or 4 V	-20	-	20	-100	100	nA
I _{IN}	Input leakage current	0 to 4.3	V _{SEL} = 0 to 4.3 V	-0.2	-	0.2	-1.0	1.0	μA
I _{CC}	Quiescent supply current	1.65 to 4.3	V _{SEL} = V _{CC} or GND	-0.2	-	0.2	-1.0	1.0	μA
I _{CCLV}	Quiescent supply current for low voltage driving	4.3	V _{SEL} = 1.65 V	-	±37	±50	-	±100	μA
			V _{SEL} = 1.80 V	-	±33	±40	-	±50	
			V _{SEL} = 2.60 V	-	±11	±20	-	±30	

1. ΔR_{ON} = max |mSN-nSN|, where m = 1, 2 and n = 1, 2, N = 1, 2
2. Flatness is defined as the difference between the maximum and minimum value of on-resistance as measured over the specified analog signal ranges.

Table 7. AC characteristics ($C_L = 35$ pf, $R_L = 50 \Omega$, $T_R = T_f \leq 5$ ns)

Symbol	Parameter	V_{CC} (V)	Test conditions	Value					Unit
				$T_A = 25 \text{ }^\circ\text{C}$			$-40 \text{ to } 85 \text{ }^\circ\text{C}$		
				Min	Typ	Max	Min	Max	
t_{PLH}, t_{PHL}	Propagation delay	1.65 - 1.95	-	-	0.21	-	-	-	ns
		2.3 - 2.7		-	0.15	-	-	-	
		3.0 - 3.3		-	0.14	-	-	-	
		3.6 - 4.3		-	0.13	-	-	-	
t_{ON}	Turn on time	1.65 - 1.95	$V_S = 0.8 \text{ V}$	-	34	-	-	-	ns
		2.3 - 2.7	$V_S = 1.5 \text{ V}$	-	20	23	-	26	
		3.0 - 3.3		-	15	17	-	20	
		3.6 - 4.3		-	13	15	-	17	
t_{OFF}	Turn off time	1.65 - 1.95	$V_S = 0.8 \text{ V}$	-	27	-	-	-	ns
		2.3 - 2.7	$V_S = 1.5 \text{ V}$	-	19	22	-	25	
		3.0 - 3.3		-	14	16	-	18	
		3.6 - 4.3		-	11	13	-	14	
t_D	Break-before-make time delay	1.65 - 1.95	$C_L = 35 \text{ pF}$ $R_L = 50 \Omega$ $V_S = 1.5 \text{ V}$	-	10	-	-	-	ns
		2.3 - 2.7		-	6	-	-	-	
		3.0 - 3.3		-	4	-	-	-	
		3.6 - 4.3		-	3	-	-	-	

Table 8. AC electrical characteristics ($C_L = 5 \text{ pF}$, $R_L = 50 \text{ } \Omega$, $T_A = 25 \text{ } ^\circ\text{C}$)

Symbol	Parameter	V_{CC} (V)	Test conditions	Value					Unit
				$T_A = 25 \text{ } ^\circ\text{C}$			$-40 \text{ to } 85 \text{ } ^\circ\text{C}$		
				Min	Typ	Max	Min	Max	
Q	Charge injection	1.65	$C_L = 100 \text{ pF}$ $V_{GEN} = 0 \text{ V}$ $R_{GEN} = 0 \text{ } \Omega$	-	3.9	-	-	-	pC
		2.3		-	4.8	-	-	-	
		3.0		-	5.2	-	-	-	
		4.3		-	6.4	-	-	-	
OIRR	OFF isolation ⁽¹⁾	1.65 – 4.3	$V_S = 1 \text{ V}_{RMS}$, $f = 1 \text{ MHz}$ Signal = 0 dBm	-	-78	-	-	-	dB
				$V_S = 1 \text{ V}_{RMS}$, $f = 10 \text{ MHz}$ Signal = 0 dBm	-	-57	-	-	
Xtalk	Crosstalk	1.65 – 4.3	$V_S = 1 \text{ V}_{RMS}$, $f = 1 \text{ MHz}$ Signal = 0 dBm		-	-78	-	-	-
				$V_S = 1 \text{ V}_{RMS}$, $f = 10 \text{ MHz}$ Signal = 0 dBm	-	-58	-	-	-
BW	-3dB bandwidth	3.0 – 4.3	$R_L = 50 \text{ } \Omega$ Signal = 0 dBm		-	800	-	-	-
C_{IN}	Control pin input capacitance		$V_{CC} = 0 \text{ V}$	-	2	-	-	-	pF
C_{ON}	Sn port capacitance when switch is enabled	3.3	$f = 240 \text{ MHz}$	-	6	-	-	-	
C_{OFF}	Sn port capacitance when switch is disabled	3.3	$f = 240 \text{ MHz}$	-	2	-	-	-	

1. Off isolation = $20 \text{ Log}_{10} (V_D/V_S)$, V_D = output, V_S = input to off switch.

Table 9. USB related AC electrical characteristics

Symbol	Parameter	V _{CC} (V)	Test conditions	Value					Unit
				T _A = 25 °C			-40 to 85 °C		
				Min	Typ	Max	Min	Max	
t _{SK(0)}	Channel-to-channel skew	3.0 - 3.6	C _L = 10 pF	–	26	–	–	–	ps
t _{SK(P)}	Skew of opposite transition of the same output	3.0 - 3.6	C _L = 10 pF	–	60	–	–	–	ps
T _J	Total jitter	3.0 - 3.6	R _L = 50 Ω C _L = 10 pF t _R = t _F = 750 ps at 480 Mbps	–	130	–	–	–	ps

Figure 6. OFF leakage

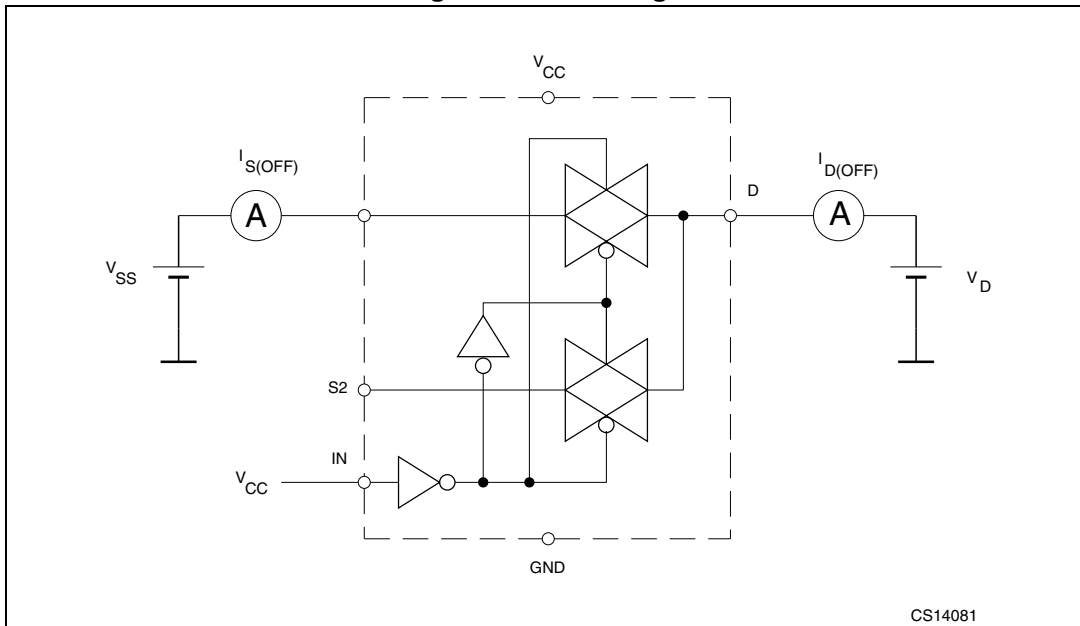

Figure 7. OFF isolation

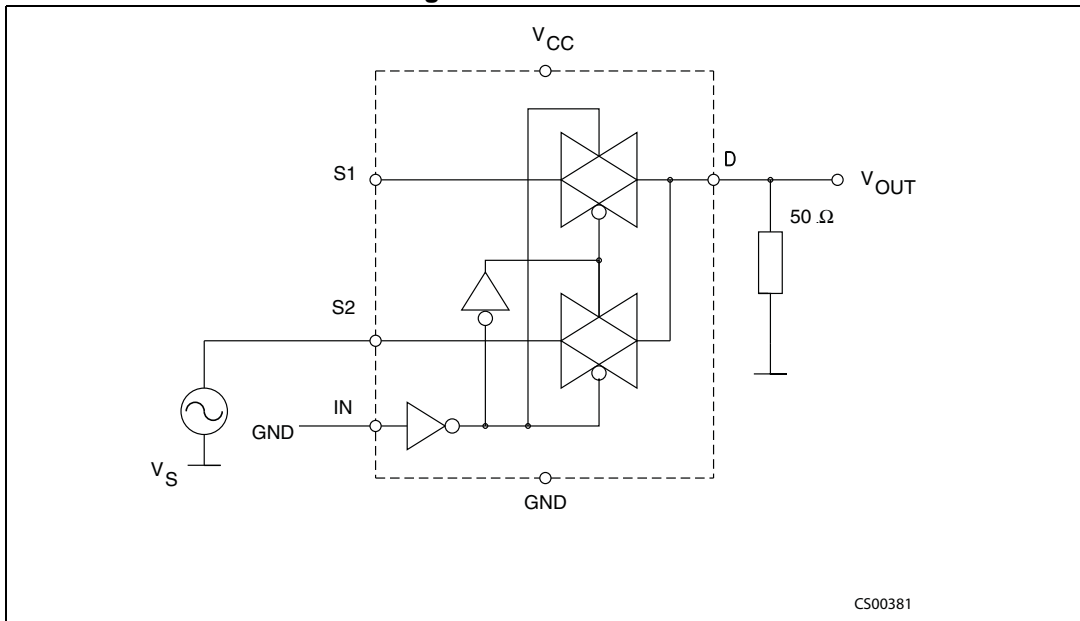

Figure 8. Bandwidth

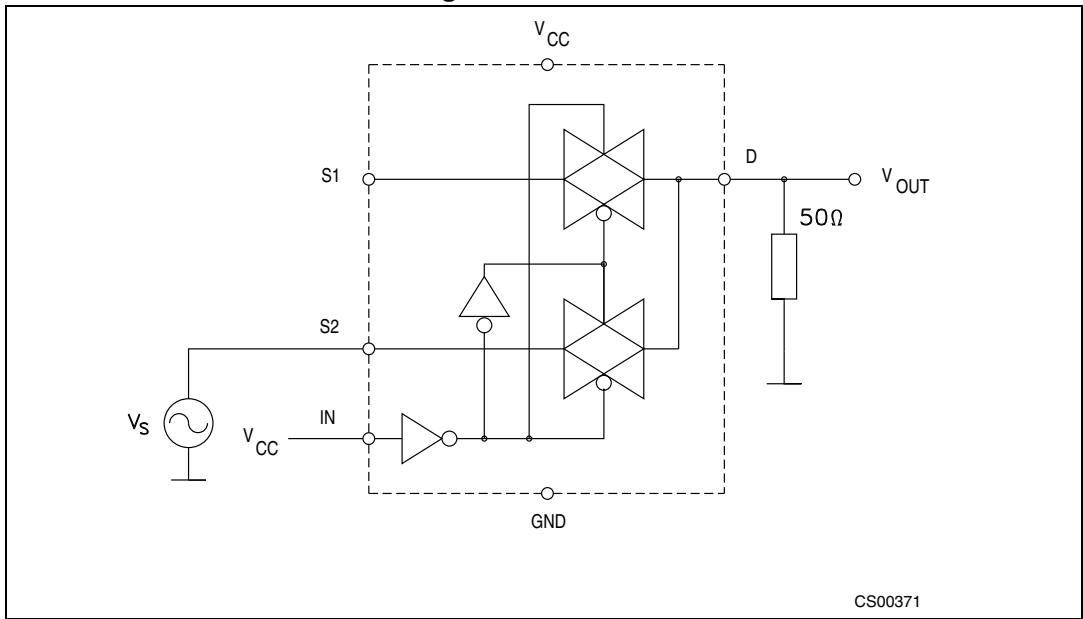

Figure 9. Channel-to-channel crosstalk

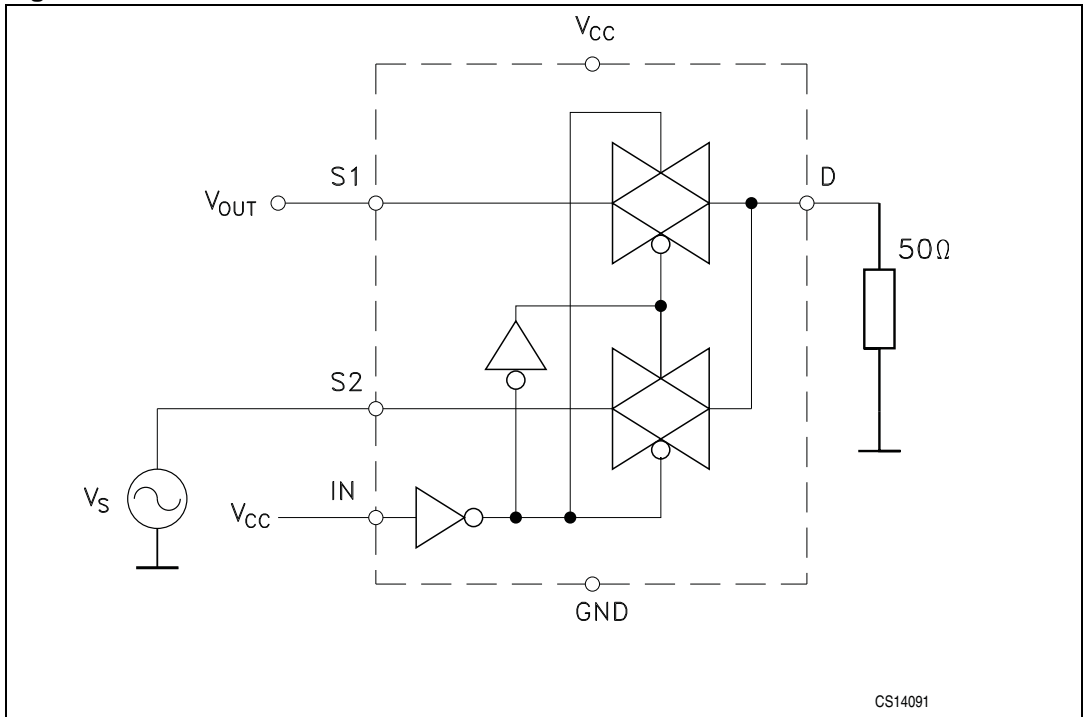
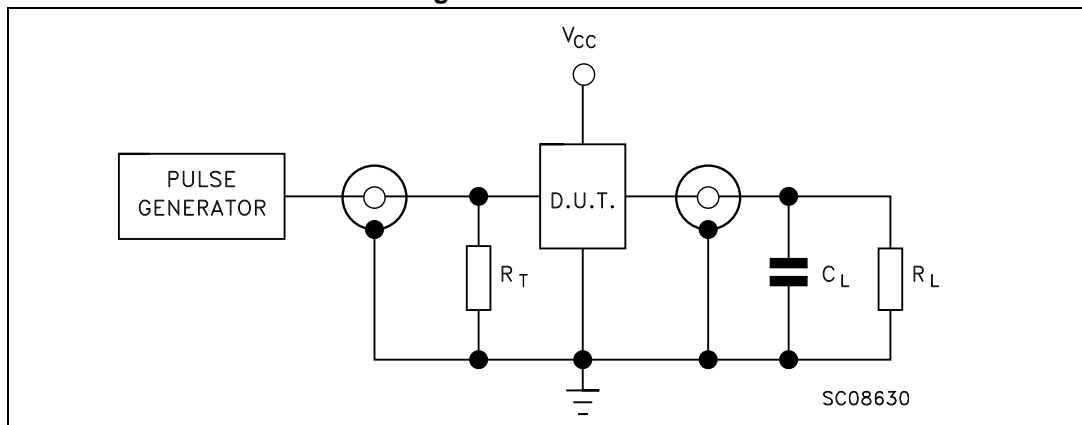

Figure 10. Test circuit



1. $C_L = 5/35$ pF or equivalent (includes jig and probe capacitance)
2. $R_L = 50 \Omega$ or equivalent
3. $R_T = Z_{OUT}$ of pulse generator (typically 50Ω)

Figure 11. Break-before-make time delay

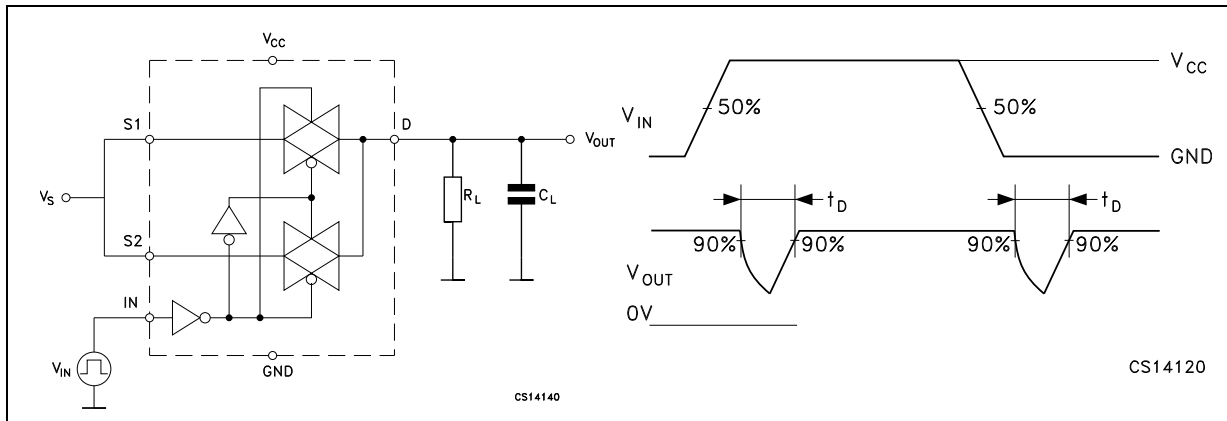

Figure 12. Switching time and charge injection ($V_{GEN} = 0\text{ V}$, $R_{GEN} = 0\ \Omega$, $R_L = 1\text{ M}\Omega$, $C_L = 100\text{ pF}$)

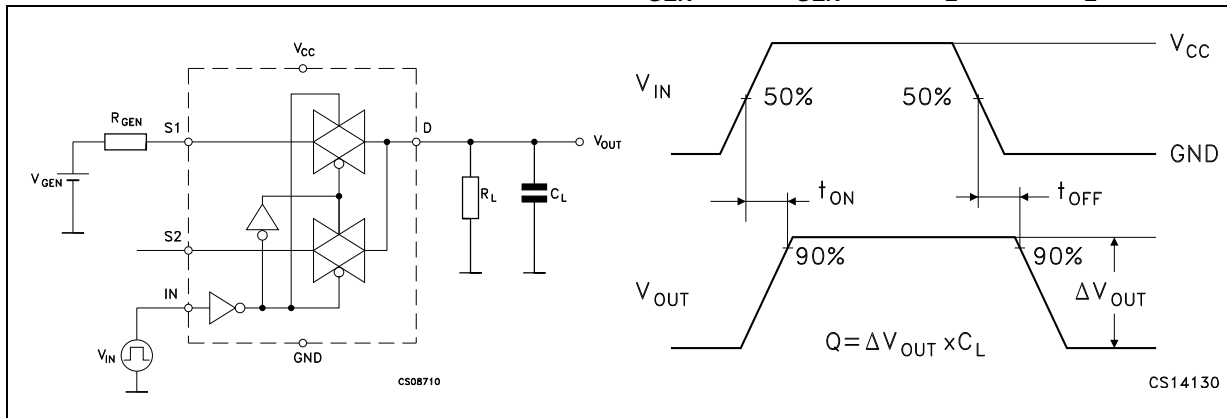
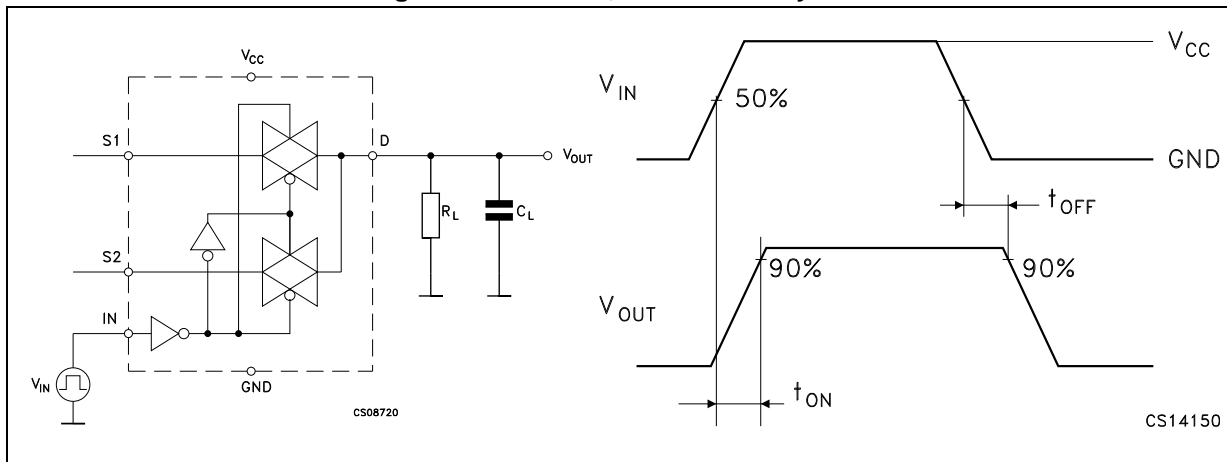

Figure 13. Turn ON, turn OFF delay time



7 Package mechanical data

In order to meet environmental requirements, ST offers these devices in different grades of ECOPACK® packages, depending on their level of environmental compliance. ECOPACK® specifications, grade definitions and product status are available at: www.st.com. ECOPACK® is an ST trademark.

Figure 14. Package outline for QFN10 (1.8 x 1.4 x 0.5 mm) - 0.4 mm pitch

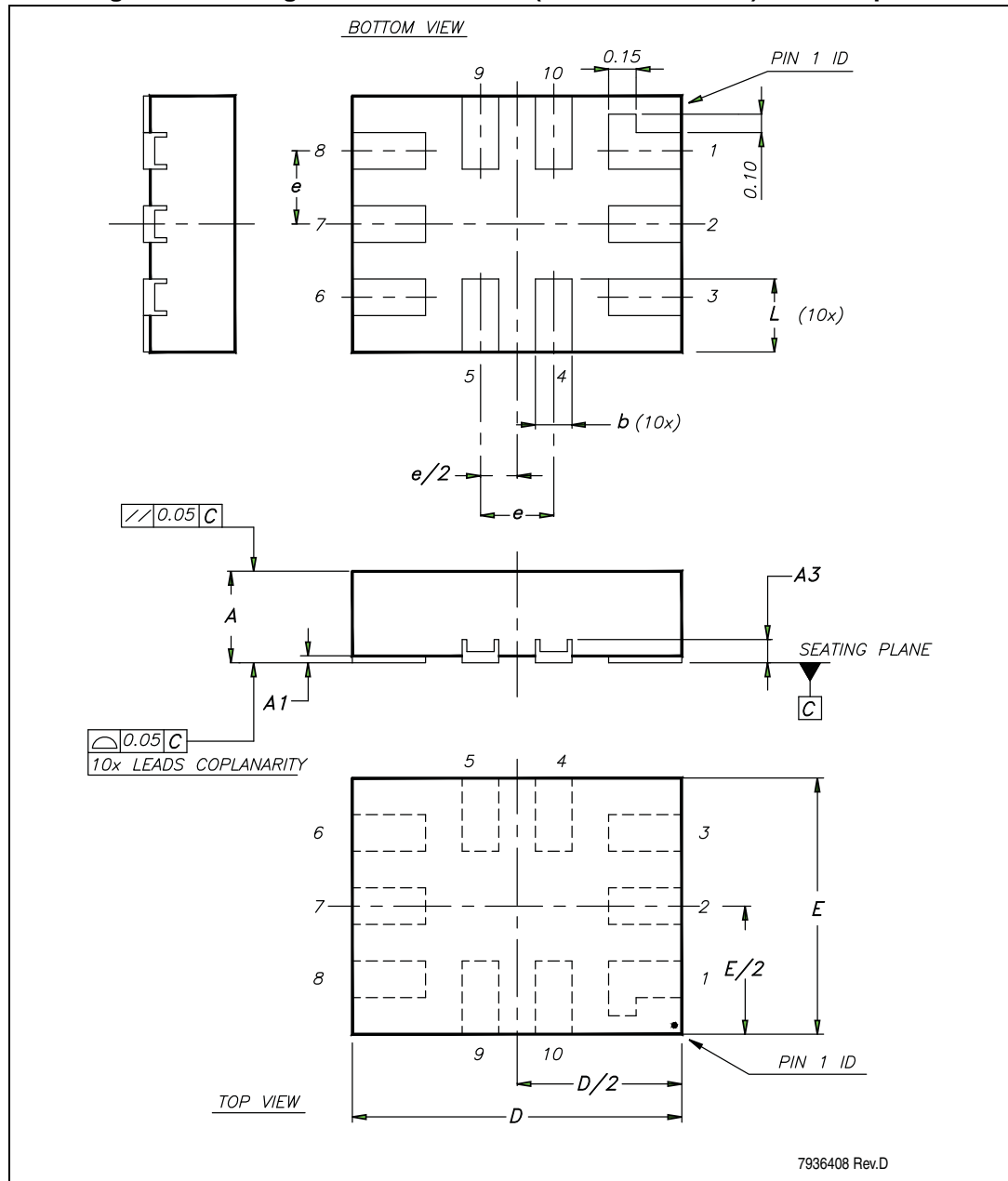

Table 10. QFN10 (1.8 x 1.4 x 0.5 mm) - 0.4 mm pitch

Symbol	Millimeters		
	Min.	Typ.	Max.
A	0.45	0.50	0.55
A1	0	0.02	0.05
A3		0.127	
b	0.15	0.20	0.25
D	1.75	1.80	1.85
E	1.35	1.40	1.45
e		0.40	
L	0.35	0.40	0.45

Figure 15. Footprint recommendations for QFN10 (1.8 x 1.4 x 0.5 mm) - 0.4 mm pitch

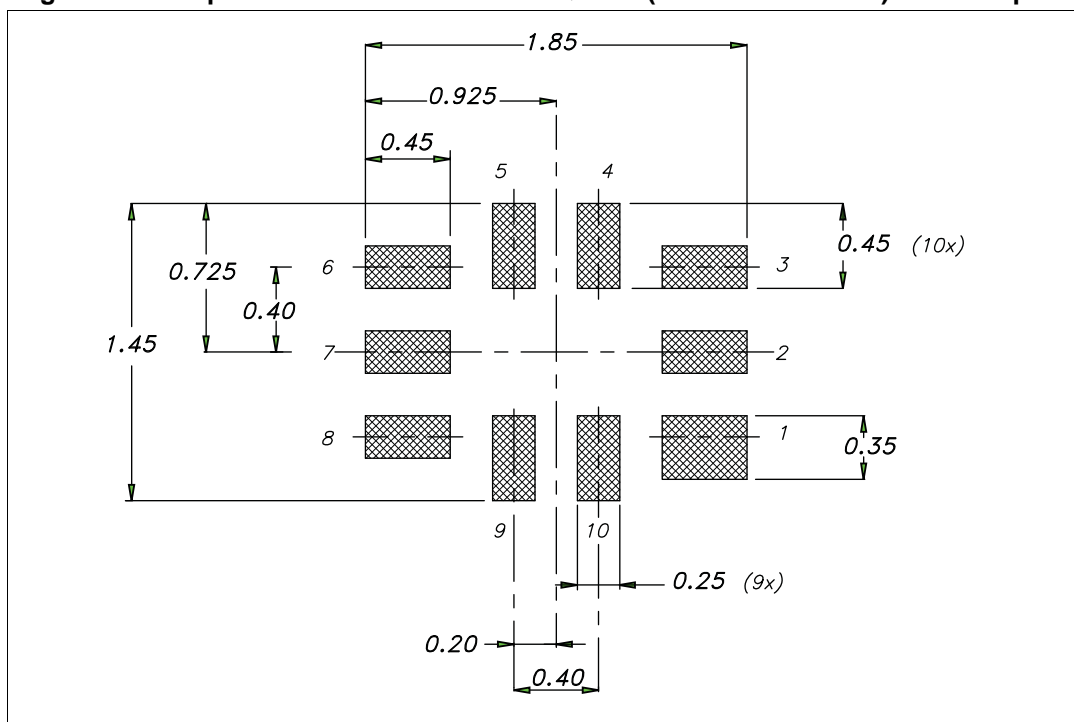

Figure 16. Carrier tape for QFN10 (1.8 x 1.4 x 0.5 mm) - 0.4 mm pitch

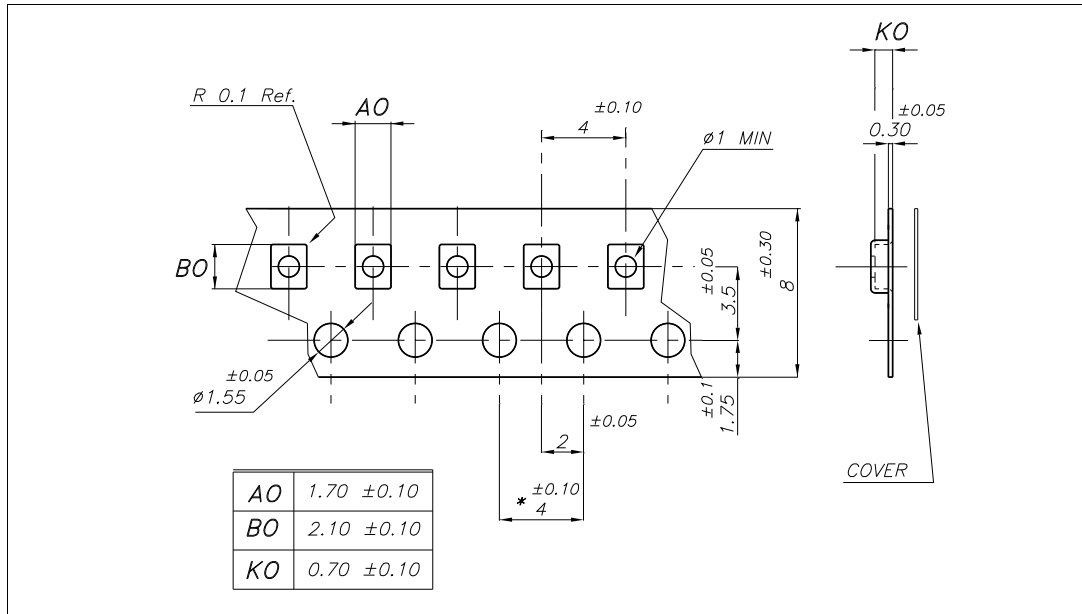

Figure 17. Reel information (front side) for QFN10 (1.8 x 1.4 x 0.5 mm) - 0.4 mm pitch

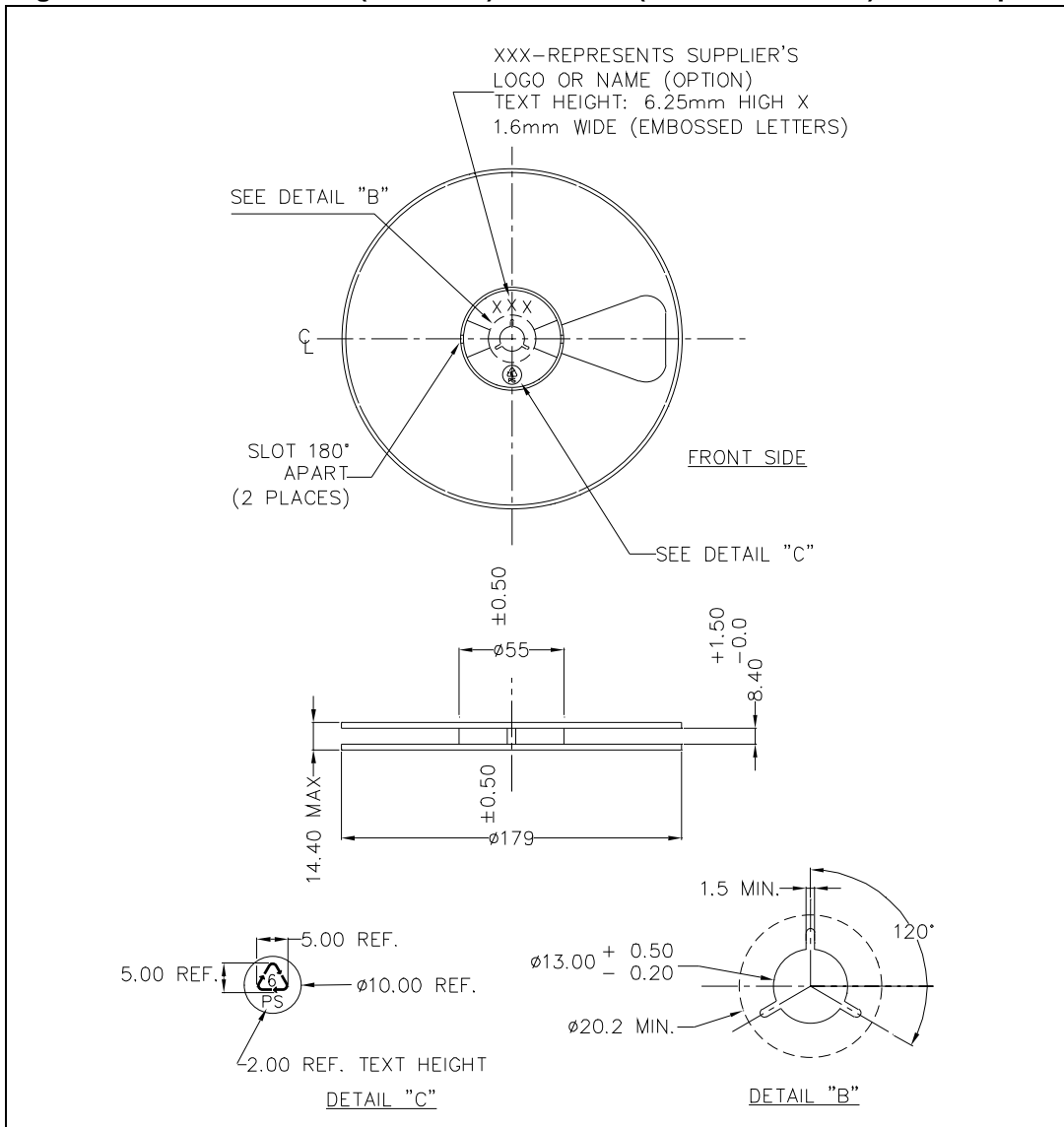
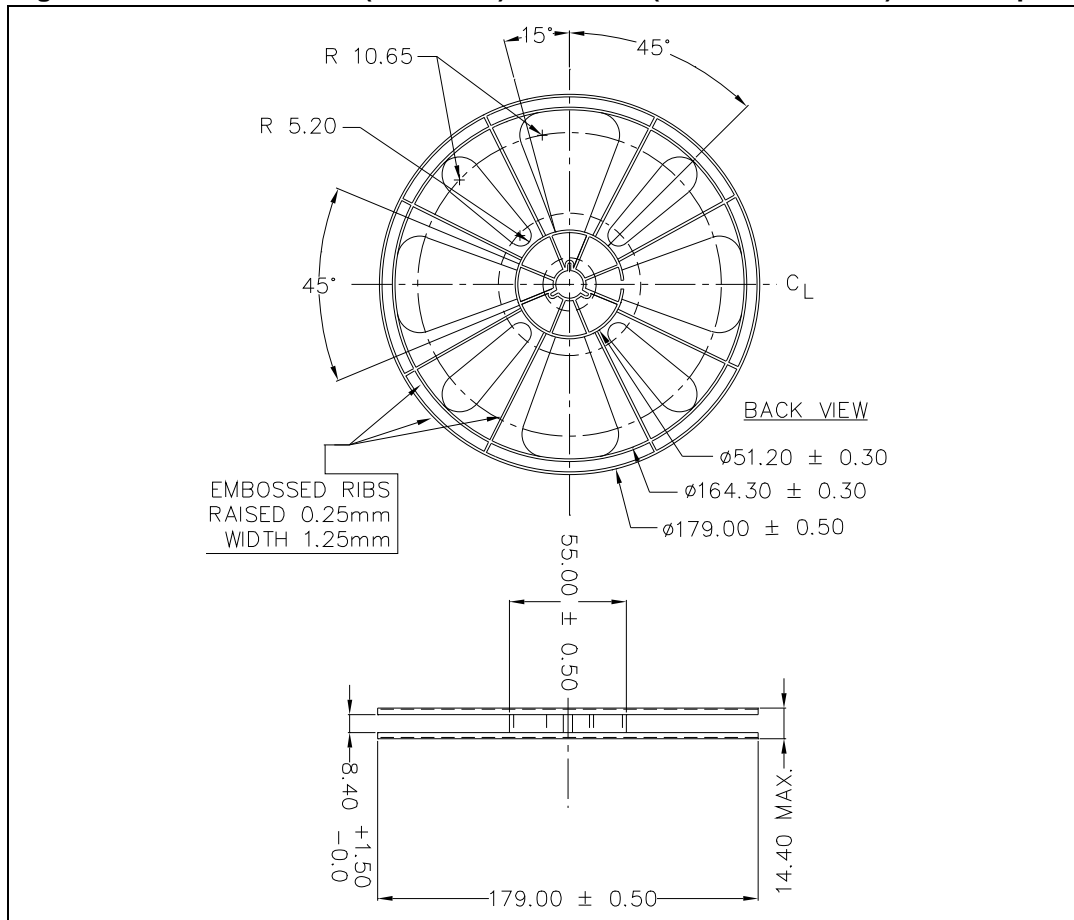

Figure 18. Reel information (back view) for QFN10 (1.8 x 1.4 x 0.5 mm) - 0.4 mm pitch



8 Revision history

Table 11. Document revision history

Date	Revision	Changes
07-Mar-2014	1	Initial release.

Please Read Carefully:

Information in this document is provided solely in connection with ST products. STMicroelectronics NV and its subsidiaries ("ST") reserve the right to make changes, corrections, modifications or improvements, to this document, and the products and services described herein at any time, without notice.

All ST products are sold pursuant to ST's terms and conditions of sale.

Purchasers are solely responsible for the choice, selection and use of the ST products and services described herein, and ST assumes no liability whatsoever relating to the choice, selection or use of the ST products and services described herein.

No license, express or implied, by estoppel or otherwise, to any intellectual property rights is granted under this document. If any part of this document refers to any third party products or services it shall not be deemed a license grant by ST for the use of such third party products or services, or any intellectual property contained therein or considered as a warranty covering the use in any manner whatsoever of such third party products or services or any intellectual property contained therein.

UNLESS OTHERWISE SET FORTH IN ST'S TERMS AND CONDITIONS OF SALE ST DISCLAIMS ANY EXPRESS OR IMPLIED WARRANTY WITH RESPECT TO THE USE AND/OR SALE OF ST PRODUCTS INCLUDING WITHOUT LIMITATION IMPLIED WARRANTIES OF MERCHANTABILITY, FITNESS FOR A PARTICULAR PURPOSE (AND THEIR EQUIVALENTS UNDER THE LAWS OF ANY JURISDICTION), OR INFRINGEMENT OF ANY PATENT, COPYRIGHT OR OTHER INTELLECTUAL PROPERTY RIGHT.

ST PRODUCTS ARE NOT DESIGNED OR AUTHORIZED FOR USE IN: (A) SAFETY CRITICAL APPLICATIONS SUCH AS LIFE SUPPORTING, ACTIVE IMPLANTED DEVICES OR SYSTEMS WITH PRODUCT FUNCTIONAL SAFETY REQUIREMENTS; (B) AERONAUTIC APPLICATIONS; (C) AUTOMOTIVE APPLICATIONS OR ENVIRONMENTS, AND/OR (D) AEROSPACE APPLICATIONS OR ENVIRONMENTS. WHERE ST PRODUCTS ARE NOT DESIGNED FOR SUCH USE, THE PURCHASER SHALL USE PRODUCTS AT PURCHASER'S SOLE RISK, EVEN IF ST HAS BEEN INFORMED IN WRITING OF SUCH USAGE, UNLESS A PRODUCT IS EXPRESSLY DESIGNATED BY ST AS BEING INTENDED FOR "AUTOMOTIVE, AUTOMOTIVE SAFETY OR MEDICAL" INDUSTRY DOMAINS ACCORDING TO ST PRODUCT DESIGN SPECIFICATIONS. PRODUCTS FORMALLY ESCC, QML OR JAN QUALIFIED ARE DEEMED SUITABLE FOR USE IN AEROSPACE BY THE CORRESPONDING GOVERNMENTAL AGENCY.

Resale of ST products with provisions different from the statements and/or technical features set forth in this document shall immediately void any warranty granted by ST for the ST product or service described herein and shall not create or extend in any manner whatsoever, any liability of ST.

ST and the ST logo are trademarks or registered trademarks of ST in various countries.

Information in this document supersedes and replaces all information previously supplied.

The ST logo is a registered trademark of STMicroelectronics. All other names are the property of their respective owners.

© 2014 STMicroelectronics - All rights reserved

STMicroelectronics group of companies

Australia - Belgium - Brazil - Canada - China - Czech Republic - Finland - France - Germany - Hong Kong - India - Israel - Italy - Japan - Malaysia - Malta - Morocco - Philippines - Singapore - Spain - Sweden - Switzerland - United Kingdom - United States of America

www.st.com

