

## 阅读申明

- 1.本站收集的数据手册和产品资料都来自互联网，版权归原作者所有。如读者和版权方有任何异议请及时告之，我们将妥善解决。
- 2.本站提供的中文数据手册是英文数据手册的中文翻译，其目的是协助用户阅读，该译文无法自动跟随原稿更新，同时也可能存在翻译上的不当。建议读者以英文原稿为参考以便获得更精准的信息。
- 3.本站提供的产品资料，来自厂商的技术支持或者使用者的心得体会等，其内容可能存在描述上的差异，建议读者做出适当判断。
- 4.如需与我们联系，请发邮件到marketing@iczoom.com，主题请标有“数据手册”字样。

## Read Statement

1. The datasheets and other product information on the site are all from network reference or other public materials, and the copyright belongs to the original author and original published source. If readers and copyright owners have any objections, please contact us and we will deal with it in a timely manner.
2. The Chinese datasheets provided on the website is a Chinese translation of the English datasheets. Its purpose is for reader's learning exchange only and do not involve commercial purposes. The translation cannot be automatically updated with the original manuscript, and there may also be improper translations. Readers are advised to use the English manuscript as a reference for more accurate information.
3. All product information provided on the website refer to solutions from manufacturers' technical support or users the contents may have differences in description, and readers are advised to take the original article as the standard.
4. If you have any questions, please contact us at marketing@iczoom.com and mark the subject with "Datasheets" .

## Non-PCI Single-Chip Full Duplex Ethernet Controller

Data Brief

### Product Features

---

- Non-PCI Single-Chip Ethernet Controller
- Fully Supports Full Duplex Switched Ethernet
- Supports Enhanced Transmit Queue Management
- 6K Bytes of On-Chip RAM
- Supports IEEE 802.3 (ANSI 8802-3) Ethernet Standards
- Automatic Detection of TX/RX Polarity Reversal
- Enhanced Power Management Features
- Supports "Magic Packet" Power Management Technology
- Hardware Memory Management Unit
- Optional Configuration via Serial EEPROM Interface (Jumperless)
- Supports single 5V or 3.3V VCC Design
- Industrial temperature range of -40°C to 85°C
- Supports Mixed Voltage External PHY Designs
- Low Power CMOS Design
- 100 Pin QFP and TQFP Lead-Free RoHS Compliant Packages (1.0mm body Thickness)
- Pin Compatible with the LAN91C92 and LAN91C94

### Bus Interface

- Direct Interface to Local Bus, with No Wait States
- Flexible Bus Interface
- 16 Bit Data and Control Paths
- Fast Access Time
- Pipelined Data Path
- Handles Block Word Transfers for any Alignment
- High Performance Chained ("Back-to-Back") Transmit and Receive

- Pin Compatible with the LAN91C92 and the LAN91C94 in Local Bus Mode
- Dynamic Memory Allocation Between Transmit and Receive
- Flat Memory Structure for Low CPU Overhead
- Buffered Architecture, Insensitive to Bus Latencies (No Overruns/Underruns)
- Supports Boot PROM for Diskless Local Bus Applications

### Network Interface

- Integrated 10BASE-T Transceiver Functions:
  - Driver and Receiver
  - Link Integrity Test
  - Receive Polarity Detection and Correction
- Integrated AUI Interface
- 10 Mb/s Manchester Encoding/Decoding and Clock Recovery
- Automatic Retransmission, Bad Packet Rejection, and Transmit Padding
- External and Internal Loopback Modes
- Four Direct Driven LEDs for Status/ Diagnostics

### Software Drivers

- LAN9000 Drivers for Major Network Operating Systems Utilizing Local Bus Interface
- Software Drivers Compatible with the LAN91C92, LAN91C94, LAN91C100FD (100 Mb/s), and LAN91C110 (100 Mb/s) Controllers in Local Bus Mode
- Software Drivers Utilize Full Capability of 32 Bit Microprocessor

**ORDER NUMBERS:**

LAN91C96i-MU for 100 pin, TQFP Lead-Free RoHS Compliant package

LAN91C96i-MS for 100 pin, QFP Lead-Free RoHS Compliant package



80 ARKAY DRIVE, HAUPPAUGE, NY 11788 (631) 435-6000, FAX (631) 273-3123

Copyright © 2008 SMSC or its subsidiaries. All rights reserved.

Circuit diagrams and other information relating to SMSC products are included as a means of illustrating typical applications. Consequently, complete information sufficient for construction purposes is not necessarily given. Although the information has been checked and is believed to be accurate, no responsibility is assumed for inaccuracies. SMSC reserves the right to make changes to specifications and product descriptions at any time without notice. Contact your local SMSC sales office to obtain the latest specifications before placing your product order. The provision of this information does not convey to the purchaser of the described semiconductor devices any licenses under any patent rights or other intellectual property rights of SMSC or others. All sales are expressly conditional on your agreement to the terms and conditions of the most recently dated version of SMSC's standard Terms of Sale Agreement dated before the date of your order (the "Terms of Sale Agreement"). The product may contain design defects or errors known as anomalies which may cause the product's functions to deviate from published specifications. Anomaly sheets are available upon request. SMSC products are not designed, intended, authorized or warranted for use in any life support or other application where product failure could cause or contribute to personal injury or severe property damage. Any and all such uses without prior written approval of an Officer of SMSC and further testing and/or modification will be fully at the risk of the customer. Copies of this document or other SMSC literature, as well as the Terms of Sale Agreement, may be obtained by visiting SMSC's website at <http://www.smcs.com>. SMSC is a registered trademark of Standard Microsystems Corporation ("SMSC"). Product names and company names are the trademarks of their respective holders.

**SMSC DISCLAIMS AND EXCLUDES ANY AND ALL WARRANTIES, INCLUDING WITHOUT LIMITATION ANY AND ALL IMPLIED WARRANTIES OF MERCHANTABILITY, FITNESS FOR A PARTICULAR PURPOSE, TITLE, AND AGAINST INFRINGEMENT AND THE LIKE, AND ANY AND ALL WARRANTIES ARISING FROM ANY COURSE OF DEALING OR USAGE OF TRADE. IN NO EVENT SHALL SMSC BE LIABLE FOR ANY DIRECT, INCIDENTAL, INDIRECT, SPECIAL, PUNITIVE, OR CONSEQUENTIAL DAMAGES; OR FOR LOST DATA, PROFITS, SAVINGS OR REVENUES OF ANY KIND; REGARDLESS OF THE FORM OF ACTION, WHETHER BASED ON CONTRACT; TORT; NEGLIGENCE OF SMSC OR OTHERS; STRICT LIABILITY; BREACH OF WARRANTY; OR OTHERWISE; WHETHER OR NOT ANY REMEDY OF BUYER IS HELD TO HAVE FAILED OF ITS ESSENTIAL PURPOSE, AND WHETHER OR NOT SMSC HAS BEEN ADVISED OF THE POSSIBILITY OF SUCH DAMAGES.**



## General Description

The LAN91C96i is a VLSI Ethernet Controller that combines Local Bus interfaces in one chip. LAN91C96i integrates all MAC and physical layer functions, as well as the packet RAM, needed to implement a high performance 10BASE-T (twisted pair) node. For 10BASE5 (thick coax), 10BASE2 (thin coax), and 10BASE-F (fiber) implementations, the LAN91C96i interfaces to external transceivers via the provided AUI port. Only one additional IC is required for most applications. The LAN91C96i comes with Full Duplex Switched Ethernet (FDSWE) support allowing the controller to provide much higher throughput. 6K bytes of RAM is provided to support enhanced throughput and compensate for any increased system service latencies. The controller implements multiple advanced powerdown modes including Magic Packet to conserve power and operate more efficiently. The LAN91C96i can directly interface with the Local Bus and deliver no-wait-state operation. For Local Bus interfaces, the LAN91C96i occupies 16 I/O locations and no memory space.

The same I/O space is used for Local Bus operations. Its shared memory is sequentially accessed with 40ns access times to any of its registers, including its packet memory. DMA services are not used by the LAN91C96i, virtually decoupling network traffic from local or system bus utilization. For packet memory management, the LAN91C96i integrates a unique hardware Memory Management Unit (MMU) with enhanced performance and decreased software overhead when compared to ring buffer and linked list architectures. The LAN91C96i is portable to different CPU and bus platforms due to its flexible bus interface, flat memory structure (no pointers), and its loosely coupled buffered architecture (not sensitive to latency).

The LAN91C96i is available in 100-pin QFP and TQFP (1.0 mm body thickness) packages; green, lead-free packages are also available. The low profile TQFP is ideal for mobile applications such as PC Card LAN adapters. The LAN91C96i operates with a single power supply voltage of 5V or 3.3V. The industrial temperature range for LAN91C96i is  $-40^{\circ}\text{C}$  to  $85^{\circ}\text{C}$ .

# Block Diagram

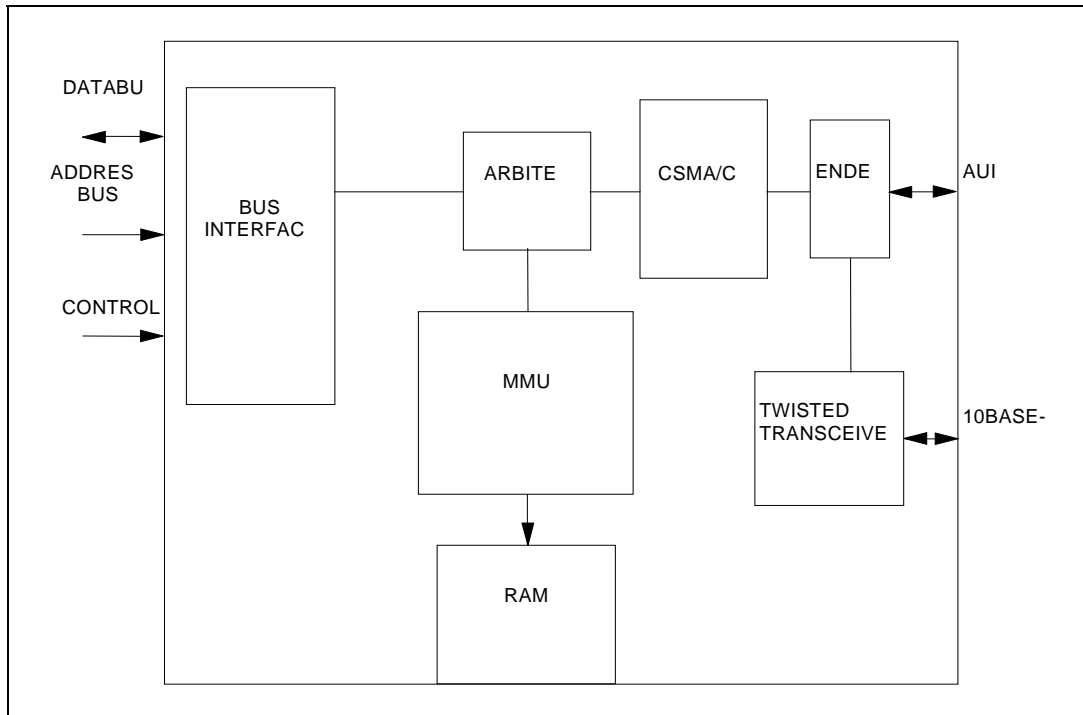

Figure 1 - LAN91C96i Internal Block Diagram

# Package Outlines

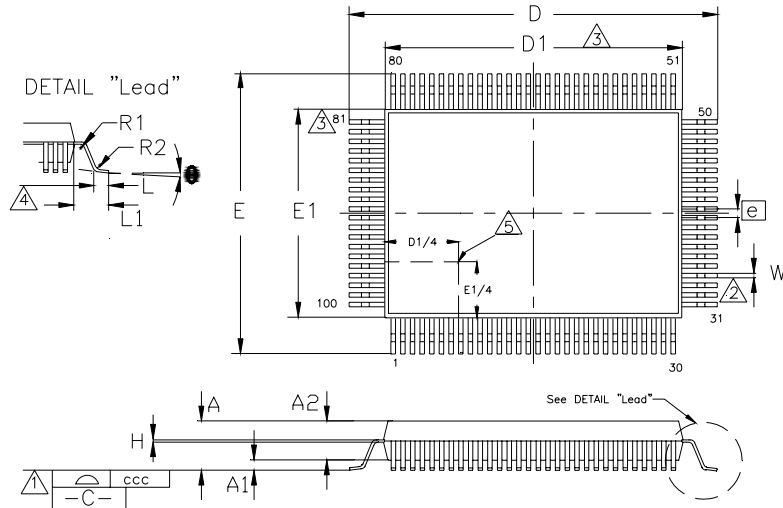

Figure 2 - 100 Pin QFP Package Outline

Table 1 - 100 Pin QFP Package Parameters

	MIN	NOMINAL	MAX	REMARKS
<b>A</b>	~	~	3.4	Overall Package Height
<b>A1</b>	0.05	~	0.5	Standoff
<b>A2</b>	2.55	~	3.05	Body Thickness
<b>D</b>	23.65	~	24.15	X Span
<b>D1</b>	19.90	~	20.10	X body Size
<b>E</b>	17.65	~	18.15	Y Span
<b>E1</b>	13.90	~	14.10	Y body Size
<b>H</b>	0.11	~	0.23	Lead Frame Thickness
<b>L</b>	0.73	0.88	1.03	Lead Foot Length
<b>L1</b>	~	1.95	~	Lead Length
<b>e</b>	0.65 Basic			Lead Pitch
<b>θ</b>	0°	~	7°	Lead Foot Angle
<b>W</b>	0.20	~	0.40	Lead Width
<b>R1</b>	0.10	~	0.25	Lead Shoulder Radius
<b>R2</b>	0.15	~	0.40	Lead Foot Radius
<b>ccc</b>	~	~	0.10	Coplanarity

**Notes:**

- <sup>1</sup> Controlling Unit: millimeter.
- <sup>2</sup> Tolerance on the true position of the leads is ± 0.065 mm maximum
- <sup>3</sup> Package body dimensions D1 and E1 do not include the mold protrusion.  
Maximum mold protrusion is 0.25 mm.
- <sup>4</sup> Dimension for foot length L measured at the gauge plane 0.25 mm above the seating plane.
- <sup>5</sup> Details of pin 1 identifier are optional but must be located within the zone indicated.

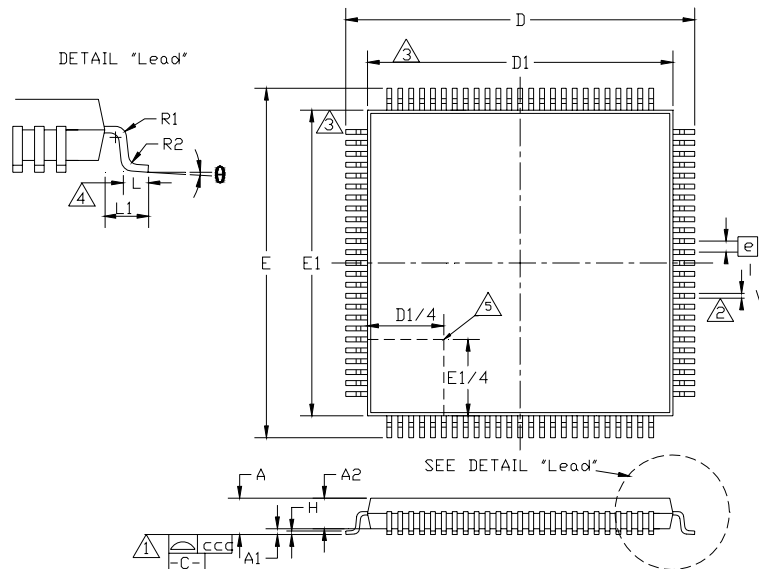
**Figure 3 - 100 Pin TQFP Package Outline**
**Table 2 - 100 Pin TQFP Package Parameters**

	MIN	NOMINAL	MAX	REMARKS
<b>A</b>	~	~	1.20	Overall Package Height
<b>A1</b>	0.05	~	0.15	Standoff
<b>A2</b>	0.95	~	1.05	Body Thickness
<b>D</b>	15.80	~	16.20	X Span
<b>D1</b>	13.90	~	14.10	X body Size
<b>E</b>	15.80	~	16.20	Y Span
<b>E1</b>	13.90	~	14.10	Y body Size
<b>H</b>	0.09	~	0.20	Lead Frame Thickness
<b>L</b>	0.45	0.60	0.75	Lead Foot Length
<b>L1</b>	~	1.00	~	Lead Length
<b>e</b>	0.50 Basic			Lead Pitch
<b>θ</b>	0°	~	7°	Lead Foot Angle
<b>W</b>	0.17	0.22	0.27	Lead Width
<b>R1</b>	0.08	~	~	Lead Shoulder Radius
<b>R2</b>	0.08	~	0.20	Lead Foot Radius
<b>ccc</b>	~	~	0.08	Coplanarity

**Notes:**

- <sup>1</sup> Controlling Unit: millimeter.
- <sup>2</sup> Tolerance on the true position of the leads is  $\pm 0.04$  mm maximum.
- <sup>3</sup> Package body dimensions D1 and E1 do not include the mold protrusion. Maximum mold protrusion is 0.25 mm.
- <sup>4</sup> Dimension for foot length L measured at the gauge plane 0.25 mm above the seating plane.
- <sup>5</sup> Details of pin 1 identifier are optional but must be located within the zone indicated.