

阅读申明

- 1.本站收集的数据手册和产品资料都来自互联网，版权归原作者所有。如读者和版权方有任何异议请及时告之，我们将妥善解决。
- 2.本站提供的中文数据手册是英文数据手册的中文翻译，其目的是协助用户阅读，该译文无法自动跟随原稿更新，同时也可能存在翻译上的不当。建议读者以英文原稿为参考以便获得更精准的信息。
- 3.本站提供的产品资料，来自厂商的技术支持或者使用者的心得体会等，其内容可能存在描述上的差异，建议读者做出适当判断。
- 4.如需与我们联系，请发邮件到marketing@iczoom.com，主题请标有“数据手册”字样。

Read Statement

1. The datasheets and other product information on the site are all from network reference or other public materials, and the copyright belongs to the original author and original published source. If readers and copyright owners have any objections, please contact us and we will deal with it in a timely manner.
2. The Chinese datasheets provided on the website is a Chinese translation of the English datasheets. Its purpose is for reader's learning exchange only and do not involve commercial purposes. The translation cannot be automatically updated with the original manuscript, and there may also be improper translations. Readers are advised to use the English manuscript as a reference for more accurate information.
3. All product information provided on the website refer to solutions from manufacturers' technical support or users the contents may have differences in description, and readers are advised to take the original article as the standard.
4. If you have any questions, please contact us at marketing@iczoom.com and mark the subject with "Datasheets" .



V386

8-BIT LVDS RECEIVER FOR VIDEO

General Description

The V386 is an ideal LVDS receiver that converts 4-pair LVDS data streams into parallel 28 bits of CMOS/TTL data with bandwidth up to 2.38 Gbps throughput or 297.5 Mbytes per second.

This chip is an ideal means to solve EMI and cable size problems associated with wide, high-speed TTL interfaces through very low-swing LVDS signals.

ICS manufactures a large variety of video application devices. Consult ICS for all of your video application requirements.

Pin Assignments

D22	1	56	VCC
D23	2	55	D21
D24	3	54	D20
GND	4	53	D19
D25	5	52	GND
D26	6	51	D18
D27	7	50	D17
LVDSGND	8	49	D16
RX0-	9	48	VCC
RX0+	10	47	D15
RX1-	11	46	D14
RX1+	12	45	D13
LVDSVCC	13	44	GND
LVDSGND	14	43	D12
RX2-	15	42	D11
RX2+	16	41	D10
RCK-	17	40	VCC
RCK+	18	39	D9
RX3-	19	38	D8
RX3+	20	37	D7
LVDSGND	21	36	GND
PLLGND	22	35	D6
PLLVCC	23	34	D5
PLLGND	24	33	D4
PWRDWN	25	32	D3
CLKOUT	26	31	VCC
D0	27	30	D2
GND	28	29	D1

56-pin TSSOP
V386

Features

- Packaged in a 56-pin TSSOP (Pb free available)
- Converts 4-pair LVDS data streams into parallel 28 bits of CMOS/TTL data
- Up to 2.38 Gbps throughput or 297.5 Megabytes/sec bandwidth
- Wide clock frequency range from 25 MHz to 85 MHz (for lower frequency requirements, please use V386-2)
- Supports VGA, SVGA, XGA, and SXGA
- LVDS voltage swing of 350 mV for low EMI
- On-chip PLL requires no external components
- Single 3.3 V low-power CMOS design
- Falling edge clock triggered outputs
- Power-down control function
- Compatible with TIA/EIA-644 LVDS standards
- Pin and function compatible with the National DS90CF386, THine THC63LVDF84, TI SN65LVDS94

Block Diagram

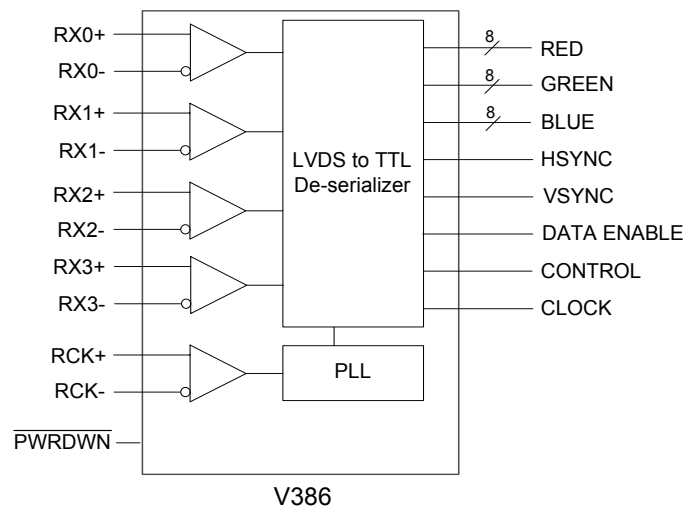



Pin Descriptions

Pin Type	Pin Count	Pins	Pin Description/Name
LVDS Differential Input	10	9, 10, 11, 12, 15, 16, 17, 18, 19, 20	8 pins (4 pairs) for Data inputs (RX0+, RX0- ; RX1+, RX1- ; RX2+, RX2- ;RX3+, RX3-) 2 pins (1 pair) for Clock Inputs (RCK+, RCK-)
Data Output	28	1, 2, 3, 5, 6, 7, 27, 29, 30, 32, 33, 34, 35, 37, 38, 39, 41, 42, 43, 45, 46, 47, 49, 50, 51, 53, 54, 55	Data outputs on pins D0 through D27
Clock Output	1	26	CLKOUT
VCC	6	13, 23, 31, 40, 48, 56	1 pin for LVDS input pairs (LVDSVCC) 1 pin for PLL (PLLVCC) 4 pins for Logic and Data outputs (VCC)
Power Down	1	25	Power-down control input ($\overline{\text{PWRDWN}}$) Active low
Ground	10	4, 8, 14, 21, 22, 24, 28, 36, 44, 5	3 pins for LVDS input pairs (LVDSGND) 2 pins for PLL (PLLGND) 5 pins for Logic and Data outputs (GND)

External Components

The V386 require no external components.

Absolute Maximum Ratings

Stresses above the ratings listed below can cause permanent damage to the V386. These ratings, which are standard values for ICS commercially rated parts, are stress ratings only. Functional operation of the device at these or any other conditions above those indicated in the operational sections of the specifications is not implied. Exposure to absolute maximum rating conditions for extended periods can affect product reliability. Electrical parameters are guaranteed only over the recommended operating temperature range.

Item	Rating
Supply Voltage, VCC	-0.3 V to +4 V
CMOS/TTL Output Voltage	-0.3 V to (VCC+0.3 V)
LVDS Receiver Input Voltage	-0.3 V to (VCC+0.3 V)
Ambient Operating Temperature	0 to +70°C
Storage Temperature	-65 to +150°C
Junction Temperature	150°C
Soldering Temperature (20 seconds max.)	260°C
Maximum Package Power	1.61 W (V386)
Package Derating	12.4 mW/°C above +25°C
	15 mW/°C above +25°C





Recommended Operation Conditions

Parameter	Min.	Typ.	Max.	Units
Ambient Operating Temperature (Ta)	0	25	+70	°C
3.3 V Supply Voltage (VCC)	3	3.3	3.6	V
CMOS/TTL Output Load (CL)			8	pF
Receiver Input Range (VIN)	0		2.4	V
Supply Noise Voltage (VN)			100	mVpp

Electrical Characteristics

VDD=3.3 V ±10%, Ambient temperature 0 to +70°C

Parameter	Symbol	Conditions	Min.	Typ.	Max.	Units
CMOS/TTL DC Specifications						
Input High Voltage	V _{IH}		2.0		VCC	V
Input Low Voltage	V _{IL}		GND		0.8	V
Output High Voltage	V _{OH}	I _{OH} = -4 mA	2.4		VCC	V
Output Low Voltage	V _{OL}	I _{OL} = 2 mA			0.4	V
Input Current	I _{IN}	0 < V _{IN} < VCC			±10	µA
Output Short Circuit Current	I _{OS}	V _{OUT} = 0V			-60	mA
LVDS Receiver DC Specifications						
Differential Input High Threshold	V _{TH}	V _{CM} = +1.2 V			+100	mV
Differential Input Low Threshold	V _{TL}		-100			mV
Input Current	I _{IN}	V _{IN} = +2.4 V, VCC = 3.6 V			±10	µA
		V _{IN} = 0V, VCC = 3.6 V			±10	µA
Receiver Supply Current						
Receiver Supply Current (worst case)	I _{CCRW}	C _L = 8 pF, worst case pattern (V386), f = 65 MHz			121	mA
		C _L = 8 pF, worst case pattern (V386), f = 85 MHz			140	mA
Receiver Supply Current (16 Grayscale)	I _{CCRG}	C _L = 8 pF, 16 Grayscale pattern, f = 65 MHz			72	mA
		C _L = 8 pF, 16 Grayscale pattern, f = 85 MHz			82	mA
Receiver Supply Current (Power Down)	I _{CCRZ}	Power_Down = Low, Receiver outputs stay low during Power-down mode			400	µA
Receiver Switching Characteristics						
CMOS Low-to-High Transition Time for Data	DLHT	20% to 80% VCC		2	6	ns
CMOS Low-to-High Transition Time for Data	DHLT	80% to 20% VCC		1.8	6	ns





Parameter	Symbol	Conditions	Min.	Typ.	Max.	Units
CMOS Low-to-High Transition Time for Clock	CLHT	20% to 80% VCC		2	6	ns
CMOS Low-to-High Transition Time for Clock	CHLT	80% to 20% VCC		1.8	6	ns
CLKOUT period	RCOP		11.76		40	ns
CLKOUT High Time	RCOH	At 2.0 V	4.5	5	25	ns
CLKOUT Low Time	RCOL	At 0.8 V	4	5	25	ns
Data Setup to CLKOUT	RSRC	At 2.0 V	3.5			ns
Data Hold to CLKOUT	RHRC	At 0.8 V	3.5			ns
RCK+/- to CLKOUT Delay	RCCD	At 85 MHz	5.5	7	9.5	ns
Receiver PLL Setup Time	RPLLS				10	ms
Receiver Power Down Delay	RPDD				10	μs
Receiver Input Strobe Position for Bit0	RSPos0	At 85 MHz, T = 11.76 ns	0.49	0.84	1.19	ns
Receiver Input Strobe Position for Bit1	RSPos1	At 85 MHz, T = 11.76 ns	2.17	2.52	2.87	ns
Receiver Input Strobe Position for Bit2	RSPos2	At 85 MHz, T = 11.76 ns	3.85	4.2	4.55	ns
Receiver Input Strobe Position for Bit3	RSPos3	At 85 MHz, T = 11.76 ns	5.53	5.88	6.23	ns
Receiver Input Strobe Position for Bit4	RSPos4	At 85 MHz, T = 11.76 ns	7.21	7.56	7.91	ns
Receiver Input Strobe Position for Bit5	RSPos5	At 85 MHz, T = 11.76 ns	8.89	9.24	9.59	ns
Receiver Input Strobe Position for Bit6	RSPos6	At 85 MHz, T = 11.76 ns	10.57	10.92	11.27	ns
RxIn Skew Margin (see note and Figure 8)	Rskm	At 85 MHz, T = 11.76 ns	300			ps
		At 65 MHz, T = 15.38 ns	500			ps

Note: The skew margins mean the maximum timing tolerance between the clock and data channel when the receiver still works well. This margin takes into account the receiver input setup and hold time, and internal clock jitter (i.e., internal data sampling window - RSPos). This margin allows for LVDS transmitter pulse position, interconnect skew, inter-symbol interference and intrinsic channel mismatch which will cause the skew between clock (RC+ and RCK-) and data (RX[n]+ and RX[n]- ; n =0, 1, 2, 3) channels.

Thermal Characteristics

Parameter	Symbol	Conditions	Min.	Typ.	Max.	Units
Thermal Resistance Junction to Ambient	θ_{JA}	Still air		84		°C/W
	θ_{JA}	1 m/s air flow		76		°C/W
	θ_{JA}	3 m/s air flow		67		°C/W
Thermal Resistance Junction to Case	θ_{JC}			50		°C/W





Timing Diagrams

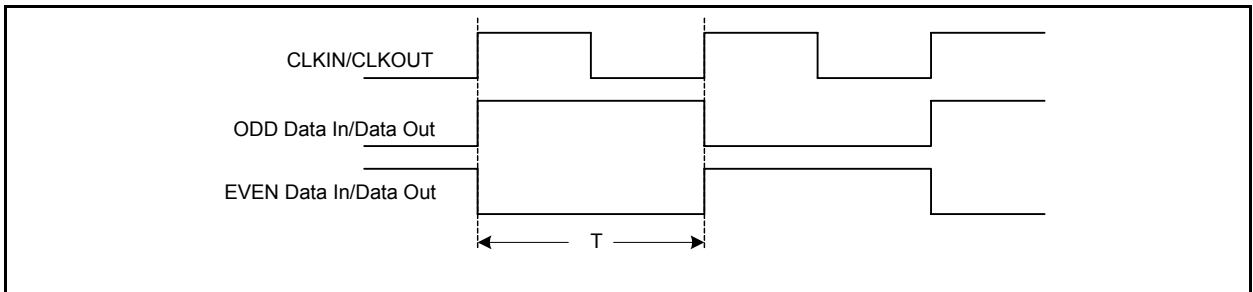

Figure 1a. "Worst Case" Test Pattern

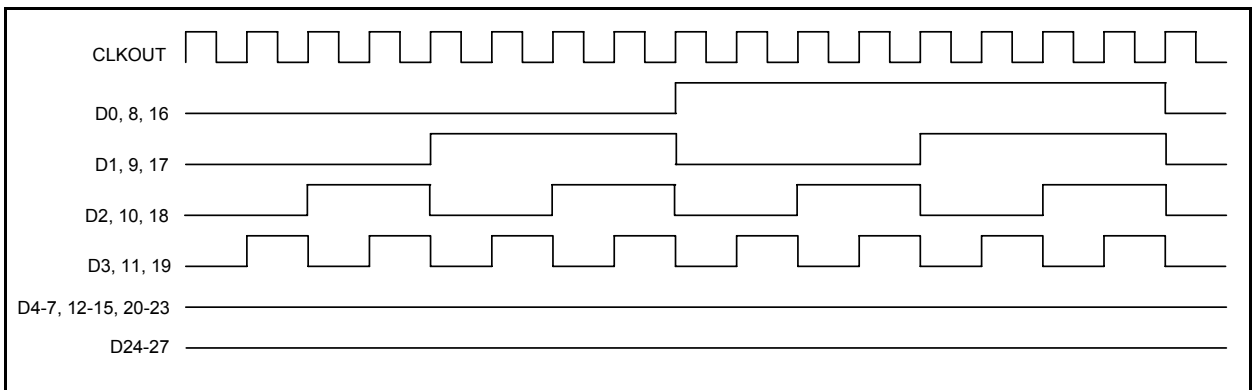

Figure 1b. 16-Grayscale Test-Pattern Waveforms

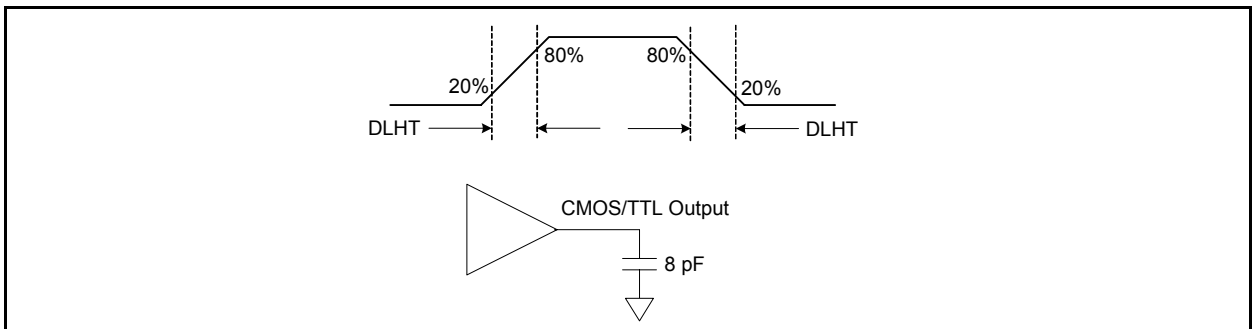

Figure 2. V386 CMOS/TTL Output Load and Transition Time



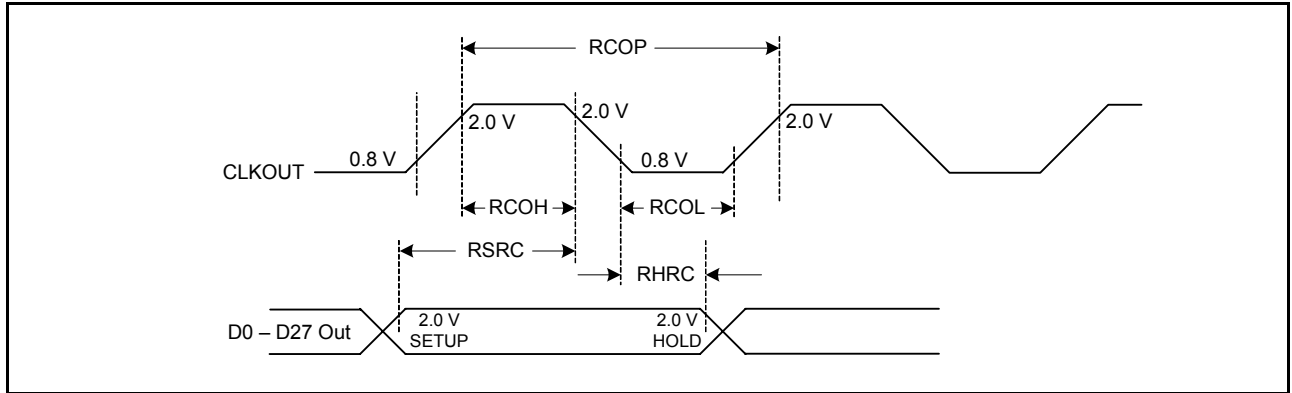

Figure 3. V386 SETUP/HOLD and High/Low Times



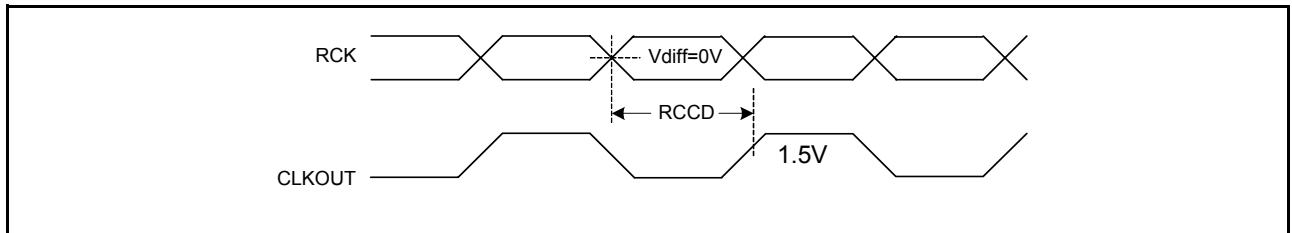

Figure 4. V386 Clock In to Clock Out Delay

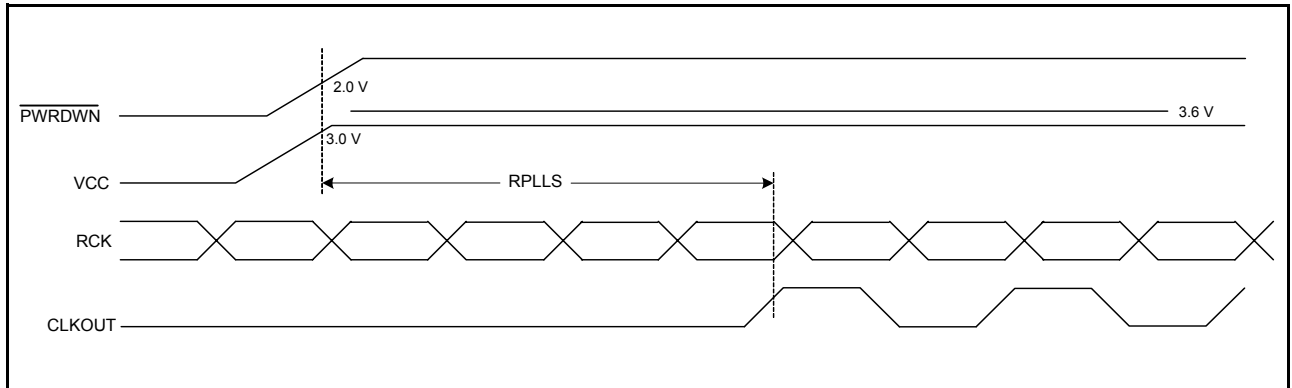

Figure 5. V386 Phase Lock Loop Set Time

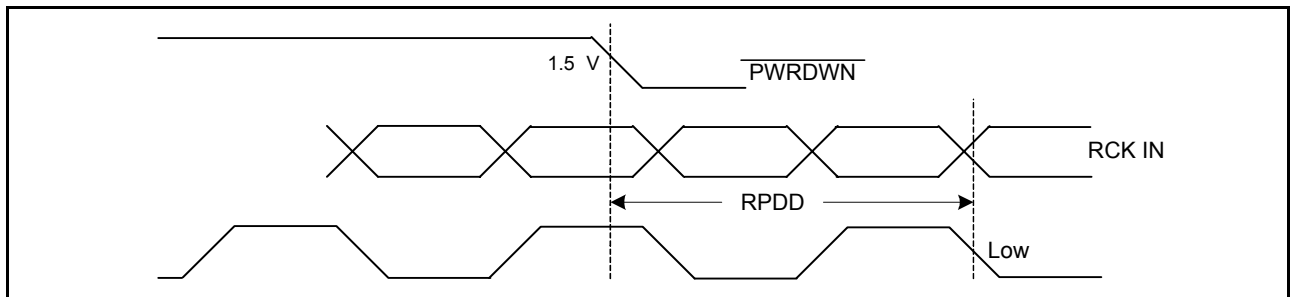

Figure 6. V386 Power Down Delay



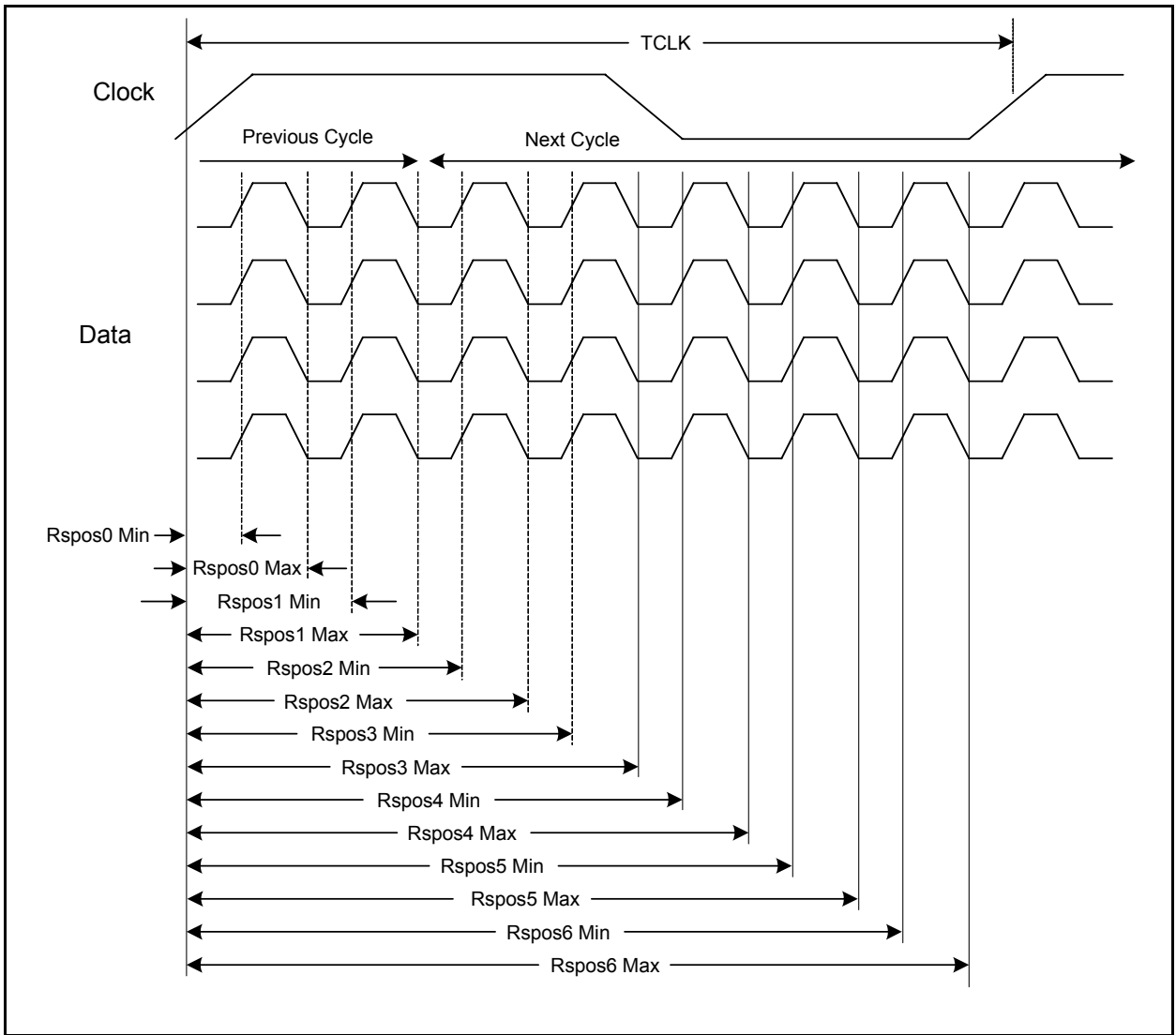

Figure 7. V386 LVDS Input Strobe Position

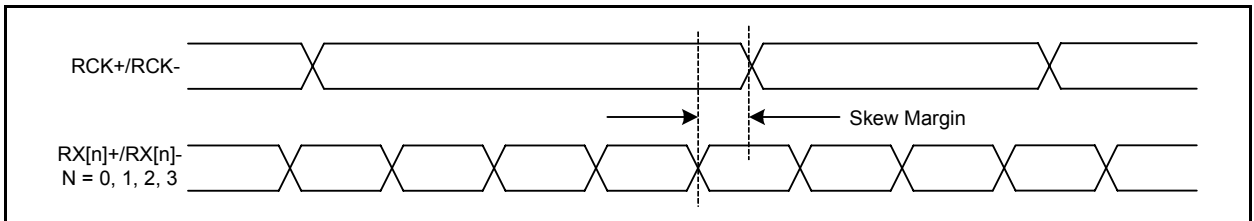

Figure 8. Receiver Input Skew Margin





Package Outline and Package Dimensions (56-pin TSSOP)

Package dimensions are kept current with JEDEC Publication No. 95

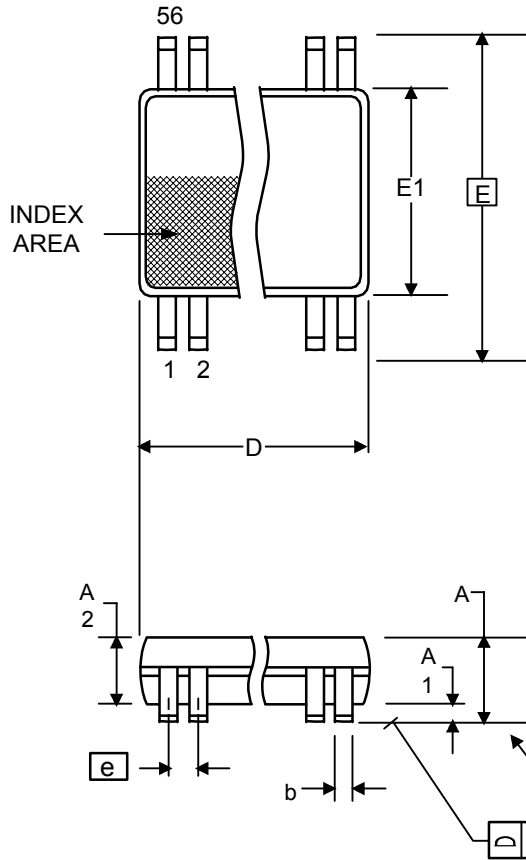

Symbol	Millimeters		Inches	
	Min	Max	Min	Max
A	—	1.20	—	0.047
A1	0.05	0.15	0.002	0.006
A2	0.80	1.05	0.032	0.041
b	0.17	0.27	0.007	0.011
C	0.09	0.20	0.0035	0.008
D	13.90	14.10	0.547	0.555
E	8.10 BASIC		0.319 BASIC	
E1	6.00	6.20	0.236	0.244
e	0.50 BASIC		0.020 BASIC	
L	0.45	0.75	0.018	0.030
a	0°	8°	0°	8°
aaa	—	0.10	—	0.004

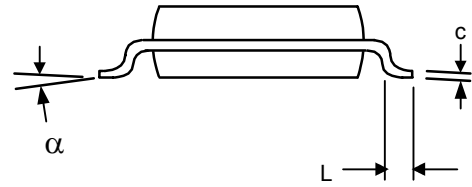

Ordering Information

Part / Order Number	Marking	Shipping Packaging	Package	Temperature
V386G	V386G	Tubes	56-pin TSSOP	0 to +70°C
V386GT	V386G	Tape and Reel	56-pin TSSOP	0 to +70°C
V386GLF	V386GLF	Tubes	56-pin TSSOP	0 to +70°C
V386GLFT	V386GLF	Tape and Reel	56-pin TSSOP	0 to +70°C

“LF” denotes Pb (lead) free annealed packaging.

While the information presented herein has been checked for both accuracy and reliability, Integrated Circuit Systems (ICS) assumes no responsibility for either its use or for the infringement of any patents or other rights of third parties, which would result from its use. No other circuits, patents, or licenses are implied. This product is intended for use in normal commercial applications. Any other applications such as those requiring extended temperature range, high reliability, or other extraordinary environmental requirements are not recommended without additional processing by ICS. ICS reserves the right to change any circuitry or specifications without notice. ICS does not authorize or warrant any ICS product for use in life support devices or critical medical instruments.

