

## 阅读申明

- 1.本站收集的数据手册和产品资料都来自互联网，版权归原作者所有。如读者和版权方有任何异议请及时告之，我们将妥善解决。
- 2.本站提供的中文数据手册是英文数据手册的中文翻译，其目的是协助用户阅读，该译文无法自动跟随原稿更新，同时也可能存在翻译上的不当。建议读者以英文原稿为参考以便获得更精准的信息。
- 3.本站提供的产品资料，来自厂商的技术支持或者使用者的心得体会等，其内容可能存在描述上的差异，建议读者做出适当判断。
- 4.如需与我们联系，请发邮件到marketing@iczoom.com，主题请标有“数据手册”字样。

## Read Statement

1. The datasheets and other product information on the site are all from network reference or other public materials, and the copyright belongs to the original author and original published source. If readers and copyright owners have any objections, please contact us and we will deal with it in a timely manner.
2. The Chinese datasheets provided on the website is a Chinese translation of the English datasheets. Its purpose is for reader's learning exchange only and do not involve commercial purposes. The translation cannot be automatically updated with the original manuscript, and there may also be improper translations. Readers are advised to use the English manuscript as a reference for more accurate information.
3. All product information provided on the website refer to solutions from manufacturers' technical support or users the contents may have differences in description, and readers are advised to take the original article as the standard.
4. If you have any questions, please contact us at marketing@iczoom.com and mark the subject with "Datasheets" .



# TSB17BA1 IEEE STD 1394b SINGLE-PORT CABLE TRANSCEIVER

SLLS568C – JANUARY 2004 – REVISED MARCH 2004

## functional block diagram

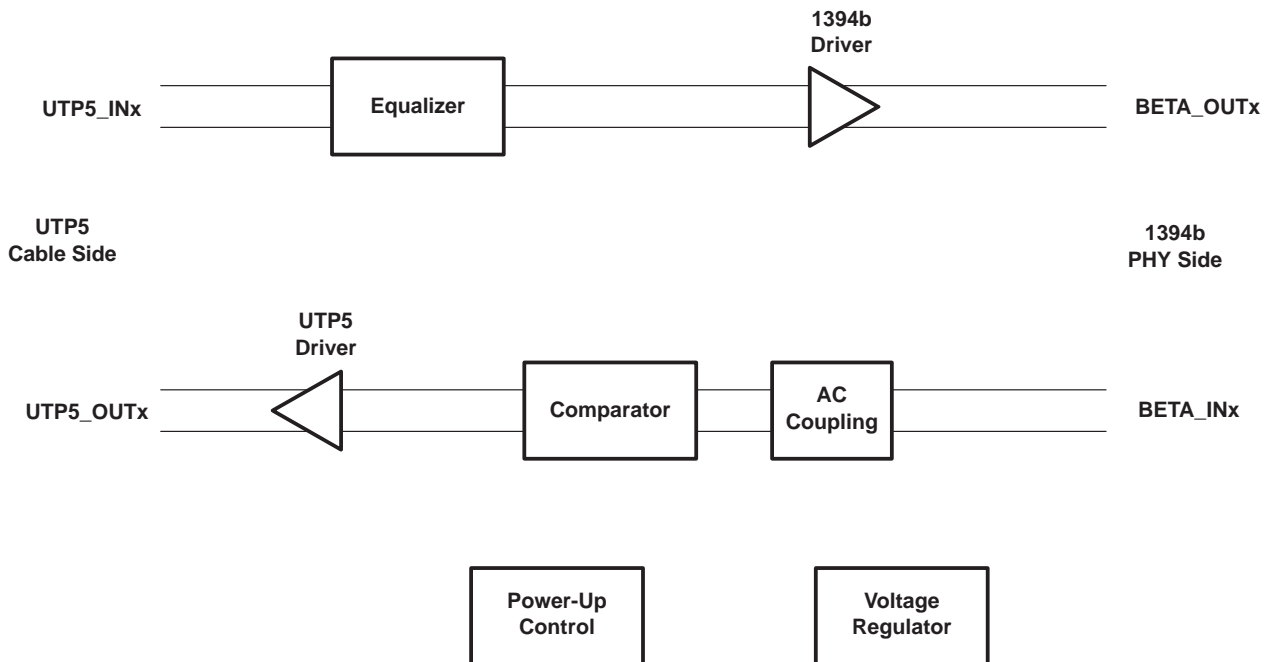

### equalizer

The equalizer applies equalization to the signal received from the UTP5 cable to boost SNR to allow sensing of the data.

### 1394b driver

This block drives the signal detected and enhanced by the equalizer from the UTP cable to a 1394b PHY port.

### ac coupling

This block blocks direct current signals to the comparator. Only ac signals are propagated through this block.

### comparator

This block converts 1394b signals from the 1394b PHY into levels capable of driving the UTP5 driver.

### UTP5 driver

This block drives signals onto the UTP5 cable.

### power-up control

This block provides a signal for the control of the device relative to the state of the supply voltage.

### voltage regulator

This block regulates an externally provided 3–3.6 V down to an internally used 1.8 V.

# TSB17BA1

## IEEE STD 1394b SINGLE-PORT CABLE TRANSCEIVER

SLLS568C – JANUARY 2004 – REVISED MARCH 2004

### Terminal Functions

TERMINAL			I/O	DESCRIPTION
NAME	TYPE	NO.		
<b>Test Terminals</b>				
E_INN	Test	2	I	Input reserved for future enhancement. Must be grounded for normal operation.
E_INP	Test	3	I	Input reserved for future enhancement. Must be grounded for normal operation.
E_OUT	Test	1	O	Output reserved for future enhancement. May be left unconnected for normal operation.
TEST0 TEST1 TEST2 TEST3	CMOS	11 12 13 14	I	Test control. These inputs are used in the manufacturing test of the TSB17BA1. For normal use, these terminals must be pulled low to GND.
<b>IEEE Std 1394b PHY Terminals</b>				
BETA_INP BETA_INN	Input from 1394b PHY	8 9	I	Input of ac-coupling block. These twisted-pair differential-signal terminals connect the TSB17BA1 BETA_INP to the 1394b PHY TPB+ and BETA_INN to the 1394b PHY TPB- terminals of the port on the 1394b PHY. Board traces from each pair of positive and negative differential signal terminals must be kept matched and as short as possible to the external load resistors and to the 1394b PHY. The transmission lines between the 1394b PHY and TSB17BA1 must be terminated properly.
BETA_OUTP BETA_OUTN	Output to 1394b PHY	5 6	O	Output of 1394b driver block. These twisted-pair differential-signal terminals, connect the TSB17BA1 BETA_OUTP to the 1394b PHY TPA+ and BETA_OUTN to the 1394b PHY TPA- terminals of the port on the 1394b PHY. Board traces from each pair of positive and negative differential signal terminals must be kept matched and as short as possible to the external load resistors and to the 1394b PHY. The transmission lines between the 1394b PHY and TSB17BA1 must be terminated properly.
<b>RJ45 Terminals</b>				
UTP5_INN	Input from UTP5 Cable	19	I	Negative differential side of input from the UTP5 cable to the TSB17BA1 termination network. Connect to network corresponding to RJ45 pin number 6 or RJ45 pin number 8.
UTP5_INP	Input from UTP5 Cable	20	I	Positive differential side of input from the UTP5 cable to the TSB17BA1 termination network. Connect to network corresponding to RJ45 pin number 3 or RJ45 pin number 7.
UTP5_OUTN	Output to UTP5 Cable	16	O	Negative differential side of output from TSB17BA1 to the UTP5 cable termination network. Connect to network corresponding to RJ45 pin number 2.
UTP5_OUTP	Output to UTP5 Cable	17	O	Positive differential side of output from TSB17BA1 to the UTP5 cable termination network. Connect to network corresponding to RJ45 pin number 1.
<b>Power and Ground Terminals</b>				
PD_SE	CMOS	10	I/O	Global power down. A high on this terminal turns off all internal circuitry.
R0	Bias	21	-	Current setting resistor. This terminal is connected to a precision external resistance to set the internal operating currents and the cable-driver output currents. This terminal has a very low impedance to ground.
R1	Bias	22	I	Current setting resistor (band-gap sense voltage). This terminal is connected to a precision external resistance to set the internal operating currents and the cable-driver output currents. A resistance of 6.04 k $\Omega$ , 1% between R0 and R1, is required to meet the 1394b output-voltage limits.
VCONTROL		23	I/O	Voltage control (reserved). Nominally not connected.
VREG_PD	CMOS	24	I	Power down for voltage regulator. When driven low, the device uses an internal regulator to generate the required 1.8 V. When driven high, the internal regulator is powered down and the 1.8 V must be supplied externally to power the 1.8-V circuitry of the device. Nominally tied low to enable the internal regulator.

**TSB17BA1**  
**IEEE STD 1394b SINGLE-PORT CABLE TRANSCEIVER**

SLLS568C – JANUARY 2004 – REVISED MARCH 2004

**Terminal Functions (Continued)**

TERMINAL			I/O	DESCRIPTION
NAME	TYPE	NO.		
<b>Power and Ground Terminals (Continued)</b>				
VDDCORE	Supply	18	–	Core power. Internal core circuit power terminal. Must be decoupled with a 1- $\mu$ F capacitor in parallel with other smaller capacitors, such as 0.001- $\mu$ F capacitors.
VDD33	Supply	7	–	3.3-V power. I/O 3.3-V circuit power terminals. A combination of high-frequency decoupling capacitors near each terminal are suggested, such as paralleled 0.1 $\mu$ F and 0.001 $\mu$ F. Lower frequency 10- $\mu$ F filtering capacitors are also recommended.
VSSCORE	Supply	15	–	Core ground. Tie to the ground plane of the PWB as close as possible to the terminal.
VSS33	Supply	4	–	3.3-V ground. Tie to the ground plane of the printed wiring board (PWB) as close as possible to the terminal.



POST OFFICE BOX 655303 • DALLAS, TEXAS 75265

**TSB17BA1**  
**IEEE STD 1394b SINGLE-PORT CABLE TRANSCEIVER**

SLLS568C – JANUARY 2004 – REVISED MARCH 2004

**absolute maximum ratings over operating free-air temperature (unless otherwise noted)†**

Supply voltage range, $V_{DD}$ (see Note 1)	.....	-0.3 V to 4 V
Input voltage range, $V_I$ (see Note 1)	.....	-0.5 V to $V_{DD} + 0.5$ V
Output voltage range at any output, $V_O$	.....	-0.5 V to $V_{DD} + 0.5$ V
Continuous total power dissipation	.....	See Dissipation Rating Table
Operating free air temperature range, $T_A$	.....	0°C to 70°C
Storage temperature range, $T_{stg}$	.....	-65°C to 150°C
Lead temperature 1,6 mm (1/16 inch) from case for 10 seconds	.....	260°C

† Stresses beyond those listed under “absolute maximum ratings” may cause permanent damage to the device. These are stress ratings only, and functional operation of the device at these or any other conditions beyond those indicated under “recommended operating conditions” is not implied. Exposure to absolute-maximum-rated conditions for extended periods may affect device reliability.

NOTE 1: All voltage values, except differential I/O bus voltages, are with respect to network ground.

**DISSIPATION RATING TABLE**

PACKAGE	$T_A \leq 25^\circ\text{C}$ POWER RATING	DERATING FACTOR ABOVE $T_A = 25^\circ\text{C}$ ‡	$T_A = 70^\circ\text{C}$ POWER RATING
PW§	0.93 W	10.9 mW/°C	0.44 W

‡ This is the inverse of the traditional junction-to-ambient thermal resistance ( $R_{\theta JA}$ ).

§ 2-oz trace and copper pad with solder.



# TSB17BA1

## IEEE STD 1394b SINGLE-PORT CABLE TRANSCEIVER

SLLS568C – JANUARY 2004 – REVISED MARCH 2004

### recommended operating conditions

		MIN	TYP†	MAX	UNIT
Supply voltage, $V_{DD33}$		3	3.3	3.6	V
Supply voltage, $V_{DDCORE}$		1.65	1.8	1.95	V
High-level input voltage, $V_{IH}$	TEST[0:3], PD_SE, VREG_PD	$0.7 \times V_{DD}$			V
Low-level input voltage, $V_{IL}$	TEST[0:3], PD_SE, VREG_PD			$0.3 \times V_{DD}$	V
Maximum junction temperature, $T_J$ (see $R_{\theta JA}$ values listed in thermal characteristics table)	$R_{\theta JA} = 91.47^\circ\text{C/W}$ , $T_A = 70^\circ\text{C}$ , high-K board			86.5	°C
	$R_{\theta JA} = 150.70^\circ\text{C/W}$ , $T_A = 70^\circ\text{C}$ , low-K board			97.1	
1394b Differential input voltage, $V_{ID}$	BETA_INP–BETA_INN	200		800	mV
1394b Common-mode input voltage, $V_{IC}$	BETA_IN cable inputs, nonsource power node	0.4706		2.015	V
Receive input jitter	BETA_INP, BETA_INN cable inputs, S100 operation			$\pm 1.08$	ns
Receive input skew	Between BETA_OUT and BETA_IN cable inputs, S100 operation			$\pm 0.8$	ns

† All typical values are at  $V_{DD} = 3.3$  V and  $T_A = 25^\circ\text{C}$ .

# TSB17BA1

## IEEE STD 1394b SINGLE-PORT CABLE TRANSCEIVER

SLLS568C – JANUARY 2004 – REVISED MARCH 2004

**electrical characteristics over recommended ranges of operating conditions (unless otherwise noted)**

### driver

PARAMETER		TEST CONDITIONS	TYP	UNIT
V <sub>OD</sub>	Differential output voltage (BETA)		705	mV
V <sub>OD</sub>	Differential output voltage (UTP5)		500	mV
I <sub>BETA</sub>	Beta drive current, BETA_OUTP, BETA_OUTN	Drivers enabled	12.5	mA
I <sub>UTP5</sub>	UTP5 drive current, UTP5_OUTP, UTP5_OUTN	Drivers enabled	10	mA

### receiver

PARAMETER		TEST CONDITIONS	MIN	TYP	MAX	UNIT
Z <sub>ID</sub>	Differential impedance	Drivers disabled	4	7		kΩ
					4	pF
Z <sub>IC</sub>	Common-mode impedance	Drivers disabled	20			kΩ
					24	pF

### device

PARAMETER		TEST CONDITIONS	TYP	UNIT
I <sub>DDSTATIC</sub>	3.3-V supply current†	No signals to driver inputs	4	mA
	V <sub>DDCORE</sub> supply current†		4	
	3.3-V supply current‡		7.5	
I <sub>DDDYN</sub>	3.3-V supply current†	Normal operation	6	mA
	V <sub>DDCORE</sub> supply current†		30	
	3.3-V supply current‡		50	

† Measured with internal regulator off, 1.8-V supply current from external source

‡ Measured with internal regulator on

### thermal characteristics

PARAMETER		TEST CONDITIONS	TYP	UNIT
R <sub>θJA</sub>	Junction-to-free-air thermal resistance	Board mounted, no air flow, high conductivity TI-recommended test board, chip soldered or greased to thermal land with 2-oz copper (high-K board)	91.5	°C/W
R <sub>θJC</sub>	Junction-to-case thermal resistance		41.2	°C/W
R <sub>θJA</sub>	Junction-to-free-air thermal resistance	Board mounted, no air flow, high conductivity JEDEC test board with 1-oz copper (low-K board)	150.7	°C/W
R <sub>θJC</sub>	Junction-to-case thermal resistance		41.2	°C/W



**TSB17BA1**  
**IEEE STD 1394b SINGLE-PORT CABLE TRANSCEIVER**

SLLS568C – JANUARY 2004 – REVISED MARCH 2004

electrical characteristics over recommended ranges of operating conditions (unless otherwise noted) (continued)

**switching characteristics**

PARAMETER		TEST CONDITIONS	MIN	TYP	MAX	UNIT
Jitter, transmit		Between BETA_OUT and BETA_IN		2		ns
Skew, transmit		Between BETA_OUT and BETA_IN			0.10	ns
		Between UTP5_OUT and UTP5_IN			0.20	
t <sub>r</sub>	TP differential rise time, transmit	10% to 90%		0.65		ns
t <sub>f</sub>	TP differential fall time, transmit	90% to 10%		0.65		ns
t <sub>r</sub>	UTP differential rise time, transmit	10% to 90%, at RJ45 connector		3.5		ns
t <sub>f</sub>	UTP differential fall time, transmit	90% to 10%, at RJ45 connector		3.5		ns

**PARAMETER MEASUREMENT INFORMATION**

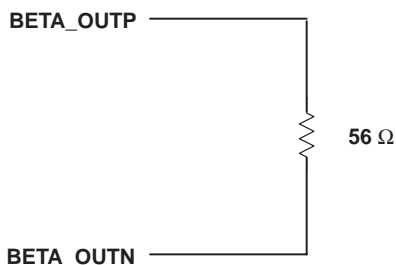

**Figure 1. Test Load for Beta Connection**

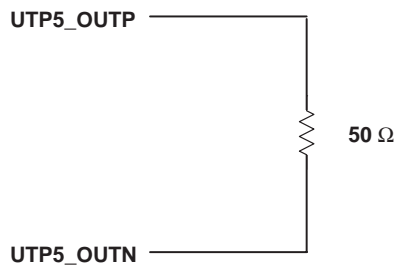

**Figure 2. Test Load for UTP5 Connection**

### APPLICATION INFORMATION



**Figure 3. 1394b Cable Termination**

#### signal coding

The signaling generated from a 1394b PHY is 8B/10B encoded. This means to send 8 bits of data requires the transmission of 10 bits across the cable. The maximum frequency that is required to send 100 Mbits/s is a fundamental frequency of 62.5 MHz (see the IEEE Std 1394b-2002 for more explanation).

#### connector pins

The current IEEE Std 1394b-2002 requires that the connection from 1394b PHY signal to the RJ45 connector pin be:

- TPB+ to RJ45 pin 1
- TPB– to RJ45 pin 2
- TPA+ to RJ45 pin 7
- TPA– to RJ45 pin 8

There is a proposal to change the IEEE Std 1394b-2002 connection from 1394b PHY signal to the RJ45 connector pin to be the same as the 100baseT Ethernet. This allows use of more 100baseT Ethernet components for 1394b connections. This changes the connections to:

- TPB+ to RJ45 pin 1
- TPB– to RJ45 pin 2
- TPA+ to RJ45 pin 3
- TPA– to RJ45 pin 6

It is anticipated that the change will be implemented into IEEE Std 1394b-2002, though it has not been ratified. Therefore, it is recommended that all implementations utilize the new pinout running TPA+ to pin 3 and TPA– to pin 6. If a closed system is created, meaning the designer controls the electronics at both ends of the UTP5 cable, then using pins 7 and 8 can give as much as a 12-dB reduction in crosstalk rather than using pins 3 and 6. Please contact Texas Instruments for further details.

#### cable connection

The IEEE Std 1394b-2002 requires the output of a TPB port to be connected to the input of a TPA port when connecting one device to a second device. In other words, it requires a crossover somewhere between the two PHY ports. The 1394b standard further states that a UTP5 device incorporates logic that can automatically implement this crossover in the logic. The TSB17BA1 does not contain this logic, therefore, the crossover must be implemented external to the TSB17BA1.

It is recommended for users of the TSB17BA1 to:

- Design the UTP5 connection to pins 1, 2 and 3, 6 as previously detailed.
- Ship an Ethernet crossover cable with their devices.

The crossover cable connects:

- Pin 1 on the near end of the cable to pin 3 on the far end of the cable
- Pin 2 on the near end of the cable to pin 6 on the far end of the cable
- Pin 3 on the near end of the cable to pin 1 on the far end of the cable
- Pin 6 on the near end of the cable to pin 2 on the far end of the cable, thereby implementing the crossover.

## APPLICATION INFORMATION

### **cable connection (continued)**

This also works for CAT5-structured wiring cable that is typically installed in a home or office. The CAT5 cables in these structured wiring installations are wired straight through and do not crossover. It is recommended that the structured wiring hub at the center of the star-type installation contain only straight-through wiring. If the RJ45 connector is brought outside the wall, then it also is connected straight through. If all networkable devices are also created as straight-through connections, then the required crossover is implemented when the networkable device is connected to the RJ45 wall-plate connection using a crossover cable.

There is a special case for the structured wiring if the wall plate enables a 4-pin, 6-pin, or 9-pin 1394b connector. In this case, one port of the 1394b PHY is connected to the 1394b connector in the typical manner. However, the connection between the 1394b PHY and the UTP5 connection inside the wall must implement a crossover. This is true if the 1394b-structured wiring hub is wired straight through and the cable pulled is straight through. In this case, since all the electrical connections between the two 1394b ports are straight through, the crossover must be implemented on the wall-plate UTP5 connection. It is required that this crossover be completed between the RJ45 connector on the wall plate and the isolating transformer of the termination network.

Please contact Texas Instruments for further detail.

### **PCB layout considerations**

There are certain signals that require special care in the layout of the TSB17BA1. The UTP5\_INP and UTP5\_INN signals are the inputs from what might be a 100-m cable. After propagating through a cable this long the signal amplitudes could be small and more easily affected by board noise. The routing for these signals from the RJ45 connector through the termination network to the PHY must be short and, if possible, a ground guard etch must be implemented to protect them from board noise. This etch must extend the length of the traces, be far enough away from the signal traces not to significantly affect the trace impedance, and be connected to the ground plane every 2 cm or less.

The precision resistor between the R1 and R0 terminals sets the internal currents and voltages of the TSB17BA1. Any noise that couples onto the R1 terminal can affect the entire device. Therefore, this connection must be kept short and as close to the TSB17BA1 as possible. This connection can also benefit from a ground guard etch around the R1 and R0 terminal connections.

To keep the noise introduced to these signals to a minimum it is recommended that no digital signals or large amplitude analog signals (like switching regulators) be routed in the vicinity of terminals 19–22 on the TSB17BA1. The output signals of the TSB17BA1 (UTP5\_OUTP, UTP5\_OUTN, BETA\_OUTP, and BETA\_OUTN) must also be routed away from these sensitive input pins.

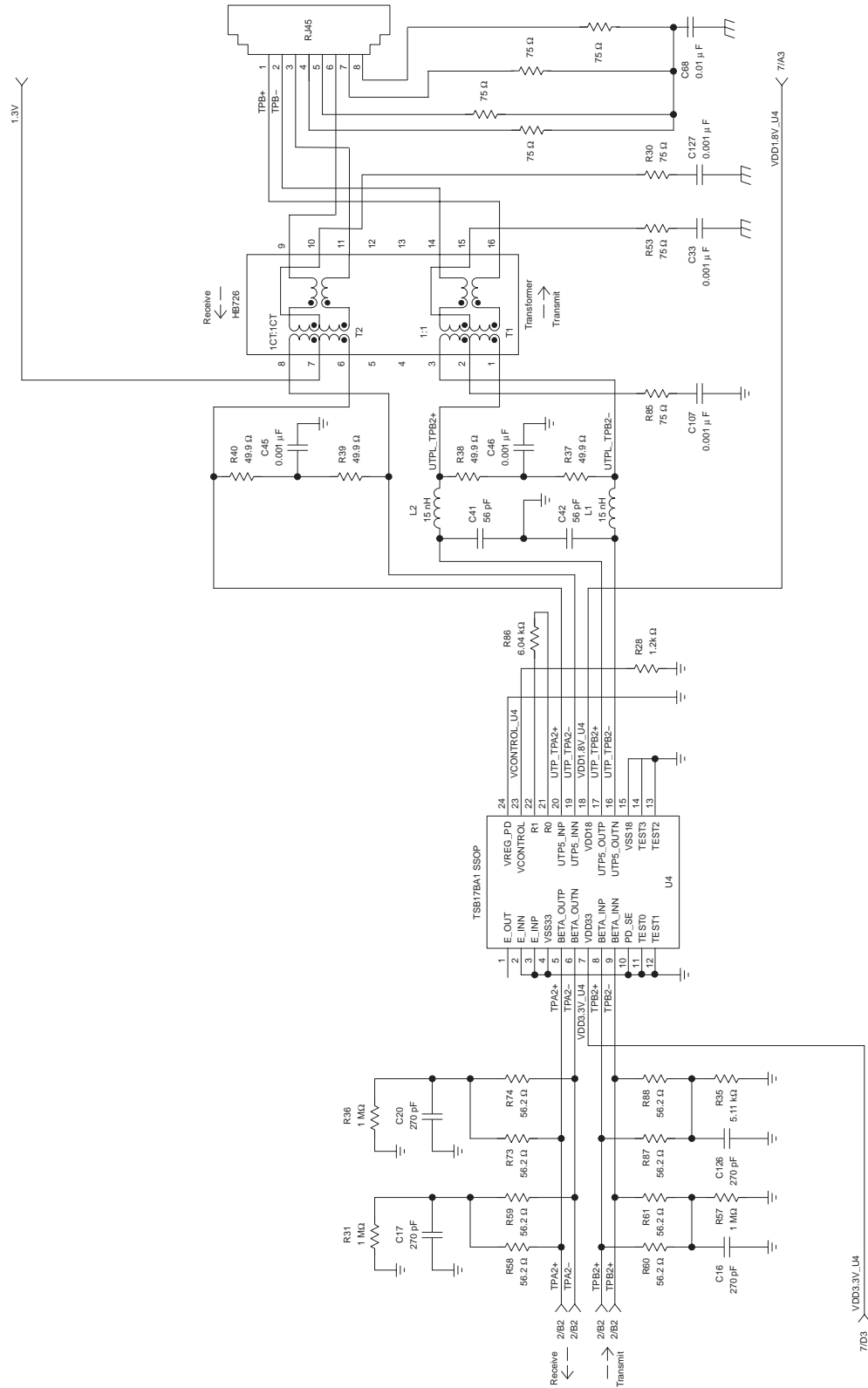

Figure 4. Example Schematic Implementation

## APPENDIX A. ERRATA

### UTP signal level detection issue

#### problem description

In some application environments, the TSB17BA1 may respond to input noise that exceeds the internal noise rejection threshold. Excessive cable length and poor quality components can contribute to the problem. Due to process variations during manufacture, the sensitivity and threshold levels may vary from device to device. One or more of the following issues may occur:

1. Some devices may be sensitive to PCB supply and input signal noise, driving the BETA\_OUT pins continuously. In turn, this may cause the 1394b PHY port connected to the TSB17BA1 to enter a blocked state, preventing connection when a node is attached to the UTP port.
2. Some devices may be sensitive to PCB and cable crosstalk from the transmit data path. This crosstalk may couple into the receive data path during the toning and training process and the 1394b PHY may then attempt to negotiate with the false crosstalk signal. The 1394b PHY port may enter a blocked state prior to UTP cable attachment at one or both cable ends.
3. System or cable noise within the signal bandwidth may translate into a differential signal input to the TSB17BA1 and falsely generate BETA\_OUT signaling. As a result, the 1394b PHY port attached to the TSB17BA1 may enter a blocked state before connection.

#### workarounds

The best problem mitigation is to avoid the circumstances that contribute to noise. The phenomenon is highly dependent on the system and the network environment, so good quality cable, good installation, and good design practice are critical. Excessively long cable runs must be avoided. Proper connector termination, high quality components (e.g., low crosstalk transformer), and good PCB layout are important. Please refer to *PCB Layout Considerations* of this data sheet for more information.

The required workaround is to provide an approximately 51-mV dc offset externally to the UTP input of the TSB17BA1 device. This may be accomplished by connecting a 1.21-k $\Omega$ , 1% resistor from the UTP5\_INN terminal to signal ground, isolating the transformer from the TSB17BA1 with 0.1- $\mu$ F capacitors and providing a 1.3-V common mode voltage. This circuit is shown in Figure 5.

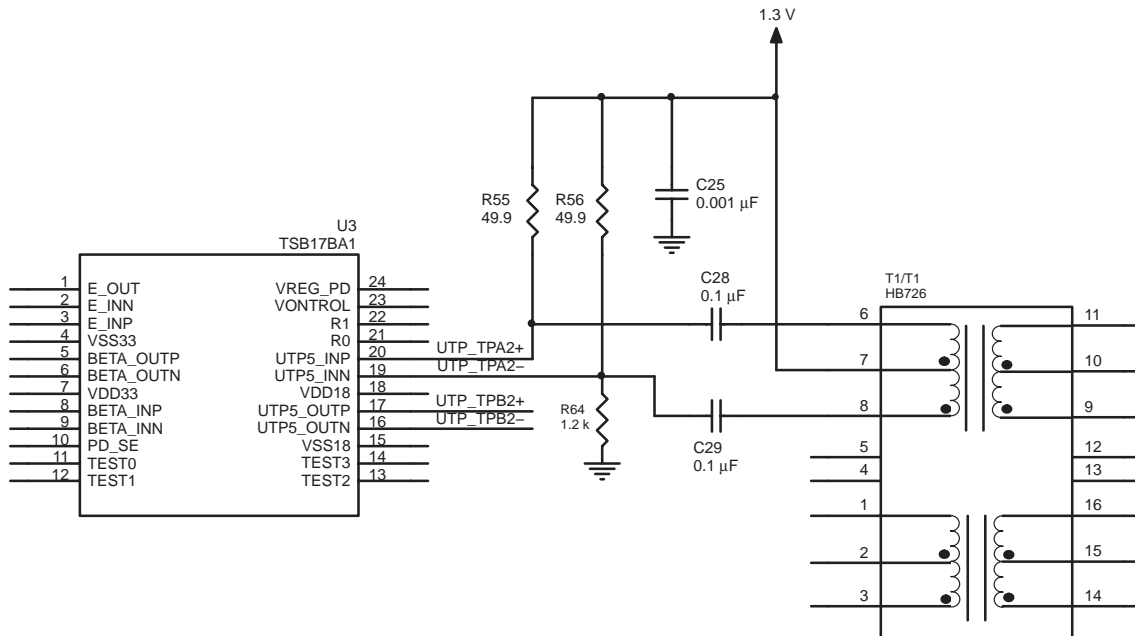

**Figure 5. Workaround Circuit**

This circuit, when used with parts received from Texas Instruments after 2003, should allow the device to reject in-band noise and crosstalk of at least 20 mVp-p. Alternate connection of the transformer center tap (pin 7) may provide noise immunity advantages.

The dc offset provided by the workaround circuit reduces the sensitivity of the device to both desired and undesired signals. This offset method proved successful with a sampling of TSB17BA1 devices (under nominal conditions) connected by 100m of CAT 5e cable in three segments with jack-to-jack adapter boards.

In some cases it may be possible to cycle system power to all nodes simultaneously after all UTP cables are connected (that is, terminated) and have ports connect normally. In this configuration the noise levels from issues 2 and 3 may be reduced by the cable termination. This noise reduction combined with the presence of a real signal may have enough signal-to-noise difference to allow the system to connect and operate. This solution may not work for issues 1 and 3 with large amplitude noise environments.

## UTP output level issue

### problem description

The TSB17BA1 UTP5\_OUT output drive level is designed and tested to the same limits that the IEEE Std 1394b-2002 specification table 12–2 provides for the transmit system. Losses in the transformer, PCB, connector, etc., of a product using the TSB17BA1 may result in degraded UTP transmit levels. These reduced output levels may not meet the 1394b specification but may still operate satisfactorily.

### workaround

None

**TSB17BA1**  
**IEEE STD 1394b SINGLE-PORT CABLE TRANSCEIVER**

SLLS568C – JANUARY 2004 – REVISED MARCH 2004

**MECHANICAL DATA**

**PW (R-PDSO-G\*\*)**

**PLASTIC SMALL-OUTLINE PACKAGE**

14 PINS SHOWN

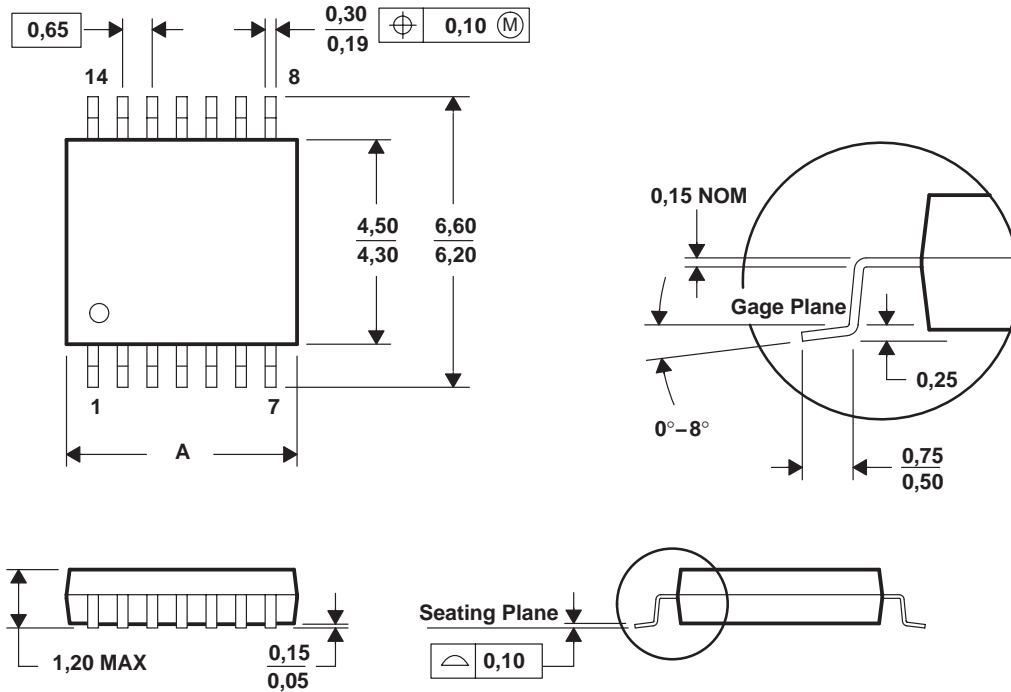

DIM \ PINS **	8	14	16	20	24	28
A MAX	3,10	5,10	5,10	6,60	7,90	9,80
A MIN	2,90	4,90	4,90	6,40	7,70	9,60

4040064/F 01/97

- NOTES: A. All linear dimensions are in millimeters.  
 B. This drawing is subject to change without notice.  
 C. Body dimensions do not include mold flash or protrusion not to exceed 0,15.  
 D. Falls within JEDEC MO-153

## IMPORTANT NOTICE

Texas Instruments Incorporated and its subsidiaries (TI) reserve the right to make corrections, modifications, enhancements, improvements, and other changes to its products and services at any time and to discontinue any product or service without notice. Customers should obtain the latest relevant information before placing orders and should verify that such information is current and complete. All products are sold subject to TI's terms and conditions of sale supplied at the time of order acknowledgment.

TI warrants performance of its hardware products to the specifications applicable at the time of sale in accordance with TI's standard warranty. Testing and other quality control techniques are used to the extent TI deems necessary to support this warranty. Except where mandated by government requirements, testing of all parameters of each product is not necessarily performed.

TI assumes no liability for applications assistance or customer product design. Customers are responsible for their products and applications using TI components. To minimize the risks associated with customer products and applications, customers should provide adequate design and operating safeguards.

TI does not warrant or represent that any license, either express or implied, is granted under any TI patent right, copyright, mask work right, or other TI intellectual property right relating to any combination, machine, or process in which TI products or services are used. Information published by TI regarding third-party products or services does not constitute a license from TI to use such products or services or a warranty or endorsement thereof. Use of such information may require a license from a third party under the patents or other intellectual property of the third party, or a license from TI under the patents or other intellectual property of TI.

Reproduction of information in TI data books or data sheets is permissible only if reproduction is without alteration and is accompanied by all associated warranties, conditions, limitations, and notices. Reproduction of this information with alteration is an unfair and deceptive business practice. TI is not responsible or liable for such altered documentation.

Resale of TI products or services with statements different from or beyond the parameters stated by TI for that product or service voids all express and any implied warranties for the associated TI product or service and is an unfair and deceptive business practice. TI is not responsible or liable for any such statements.

Following are URLs where you can obtain information on other Texas Instruments products and application solutions:

<b>Products</b>		<b>Applications</b>	
Amplifiers	<a href="http://amplifier.ti.com">amplifier.ti.com</a>	Audio	<a href="http://www.ti.com/audio">www.ti.com/audio</a>
Data Converters	<a href="http://dataconverter.ti.com">dataconverter.ti.com</a>	Automotive	<a href="http://www.ti.com/automotive">www.ti.com/automotive</a>
DSP	<a href="http://dsp.ti.com">dsp.ti.com</a>	Broadband	<a href="http://www.ti.com/broadband">www.ti.com/broadband</a>
Interface	<a href="http://interface.ti.com">interface.ti.com</a>	Digital Control	<a href="http://www.ti.com/digitalcontrol">www.ti.com/digitalcontrol</a>
Logic	<a href="http://logic.ti.com">logic.ti.com</a>	Military	<a href="http://www.ti.com/military">www.ti.com/military</a>
Power Mgmt	<a href="http://power.ti.com">power.ti.com</a>	Optical Networking	<a href="http://www.ti.com/opticalnetwork">www.ti.com/opticalnetwork</a>
Microcontrollers	<a href="http://microcontroller.ti.com">microcontroller.ti.com</a>	Security	<a href="http://www.ti.com/security">www.ti.com/security</a>
		Telephony	<a href="http://www.ti.com/telephony">www.ti.com/telephony</a>
		Video & Imaging	<a href="http://www.ti.com/video">www.ti.com/video</a>
		Wireless	<a href="http://www.ti.com/wireless">www.ti.com/wireless</a>

Mailing Address: Texas Instruments  
Post Office Box 655303 Dallas, Texas 75265