

阅读申明

- 1.本站收集的数据手册和产品资料都来自互联网，版权归原作者所有。如读者和版权方有任何异议请及时告之，我们将妥善解决。
- 2.本站提供的中文数据手册是英文数据手册的中文翻译，其目的是协助用户阅读，该译文无法自动跟随原稿更新，同时也可能存在翻译上的不当。建议读者以英文原稿为参考以便获得更精准的信息。
- 3.本站提供的产品资料，来自厂商的技术支持或者使用者的心得体会等，其内容可能存在描述上的差异，建议读者做出适当判断。
- 4.如需与我们联系，请发邮件到marketing@iczoom.com，主题请标有“数据手册”字样。

Read Statement

1. The datasheets and other product information on the site are all from network reference or other public materials, and the copyright belongs to the original author and original published source. If readers and copyright owners have any objections, please contact us and we will deal with it in a timely manner.
2. The Chinese datasheets provided on the website is a Chinese translation of the English datasheets. Its purpose is for reader's learning exchange only and do not involve commercial purposes. The translation cannot be automatically updated with the original manuscript, and there may also be improper translations. Readers are advised to use the English manuscript as a reference for more accurate information.
3. All product information provided on the website refer to solutions from manufacturers' technical support or users the contents may have differences in description, and readers are advised to take the original article as the standard.
4. If you have any questions, please contact us at marketing@iczoom.com and mark the subject with "Datasheets" .

LIN Transceiver

TLE 6259-2

Automotive and
Industrial



Never stop thinking.

Single-Wire-Transceiver

TLE 6259-2

Final Datasheet

1 Overview

1.1 Features

- Single-wire transceiver, suitable for **LIN** protocol
- Transmission rate up to 20 kBaud
- Compatible to LIN specification 1.2
- Compatible to ISO 9141 functions
- Very low current consumption in sleep mode
- Control output for voltage regulator
- Bus short to GND protection
- Short circuit proof to ground and battery
- Overtemperature protection

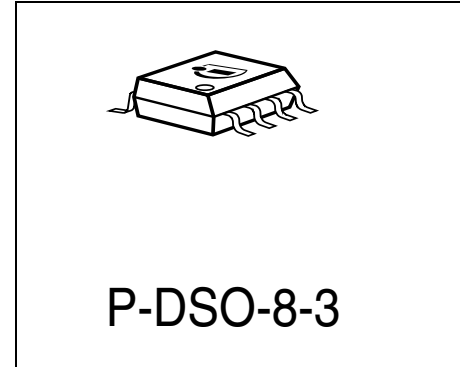

Type	Ordering Code	Package
TLE 6259-2G	Q 67006 - A 9596	P-DSO-8-3

Description

The TLE 6259-2 is a monolithic integrated circuit in a P-DSO-8-3 package. It works as an interface between the protocol controller and the physical bus. The TLE 6259-2 is especially suitable to drive the bus line in LIN systems in automotive and industrial applications. Further it can be used in standard ISO9141 systems. The TLE6259-2 has a BUS short to GND feature implemented, to avoid a battery discharge.

In order to reduce the current consumption, the TLE 6259-2 offers a sleep operation mode. In this mode a voltage regulator can be controlled to minimize the current consumption of the whole application. A wake-up caused by a message on the bus, enables the voltage regulator and sets the RxD output LOW until the device is switched to normal operation mode.

The IC is based on the Smart Power Technology SPT® which allows bipolar and CMOS control circuitry in accordance with DMOS power devices existing on the same monolithic circuit.

The TLE 6259-2 is designed to withstand the severe conditions of automotive applications.

1.2 Pin Configuration (top view)

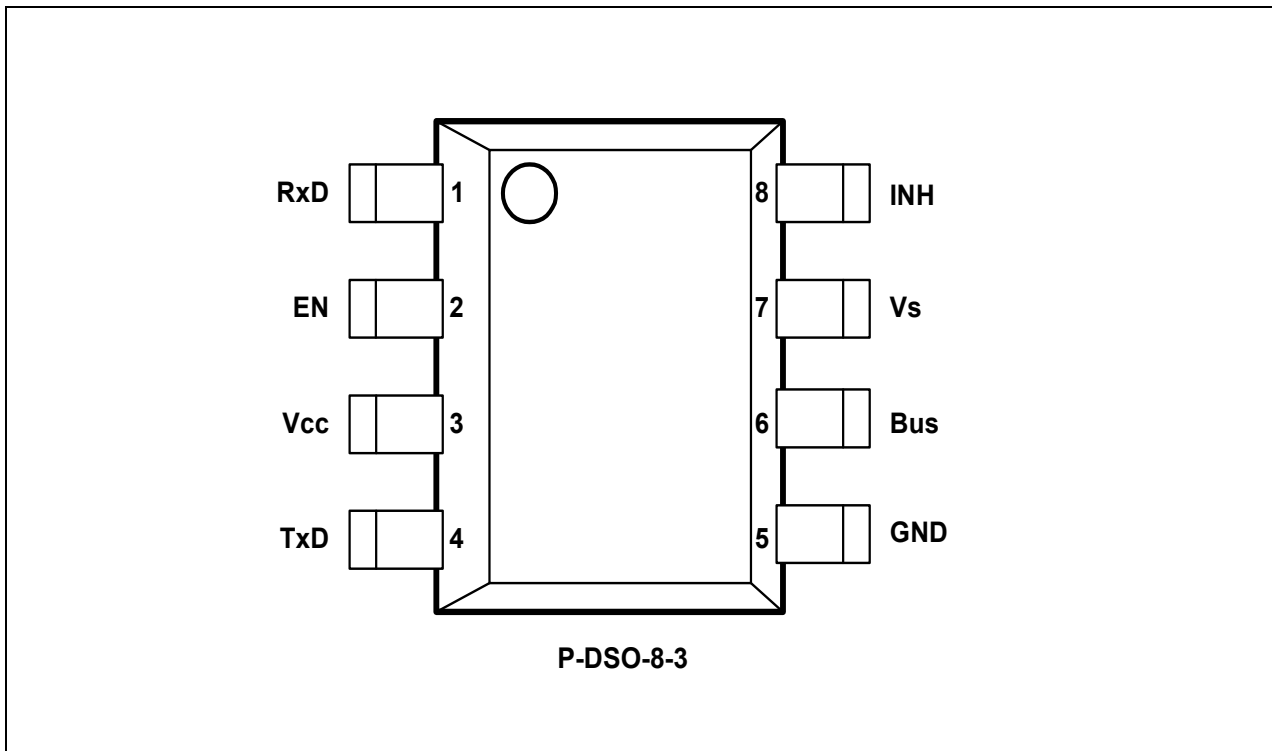

Figure 1

1.3 Pin Definitions and Functions:

Pin No.	Symbol	Function
1	RxD	Receive data output; integrated pull up, LOW in dominant state,
2	EN	Enable input; integrated 30 kΩ pull down, transceiver in normal operation mode when HIGH
3	V _{CC}	5V supply input;
4	TxD	Transmit data input; integrated pull up, LOW in dominant state
5	GND	Ground;
6	Bus	Bus output/input; internal 30 kΩ pull up, LOW in dominant state
7	V _s	Battery supply input;
8	INH	Inhibit output; to control a voltage regulator, becomes HIGH when wake-up via LIN bus occurs

1.4 Functional Block Diagram

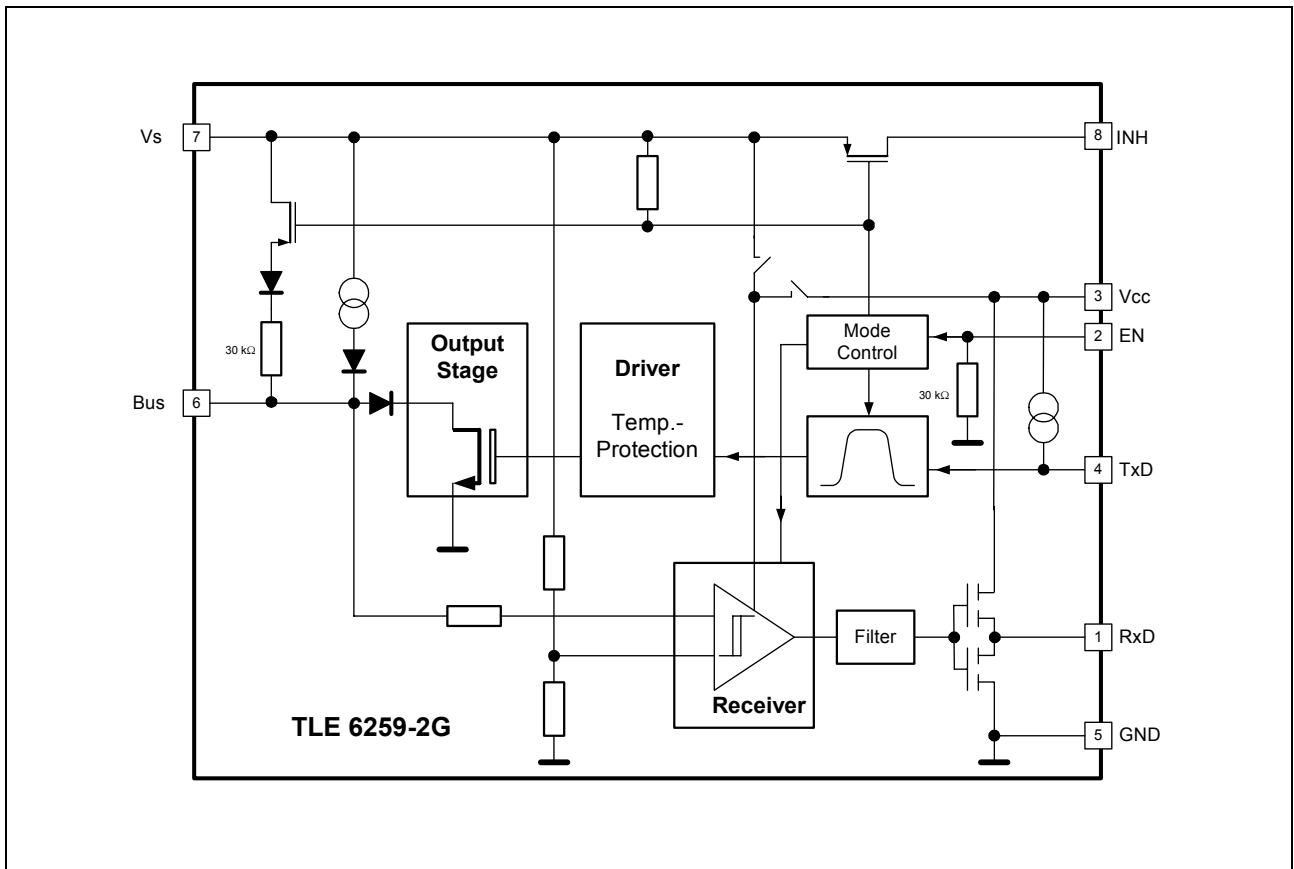

Figure 2

1.5 Application Information

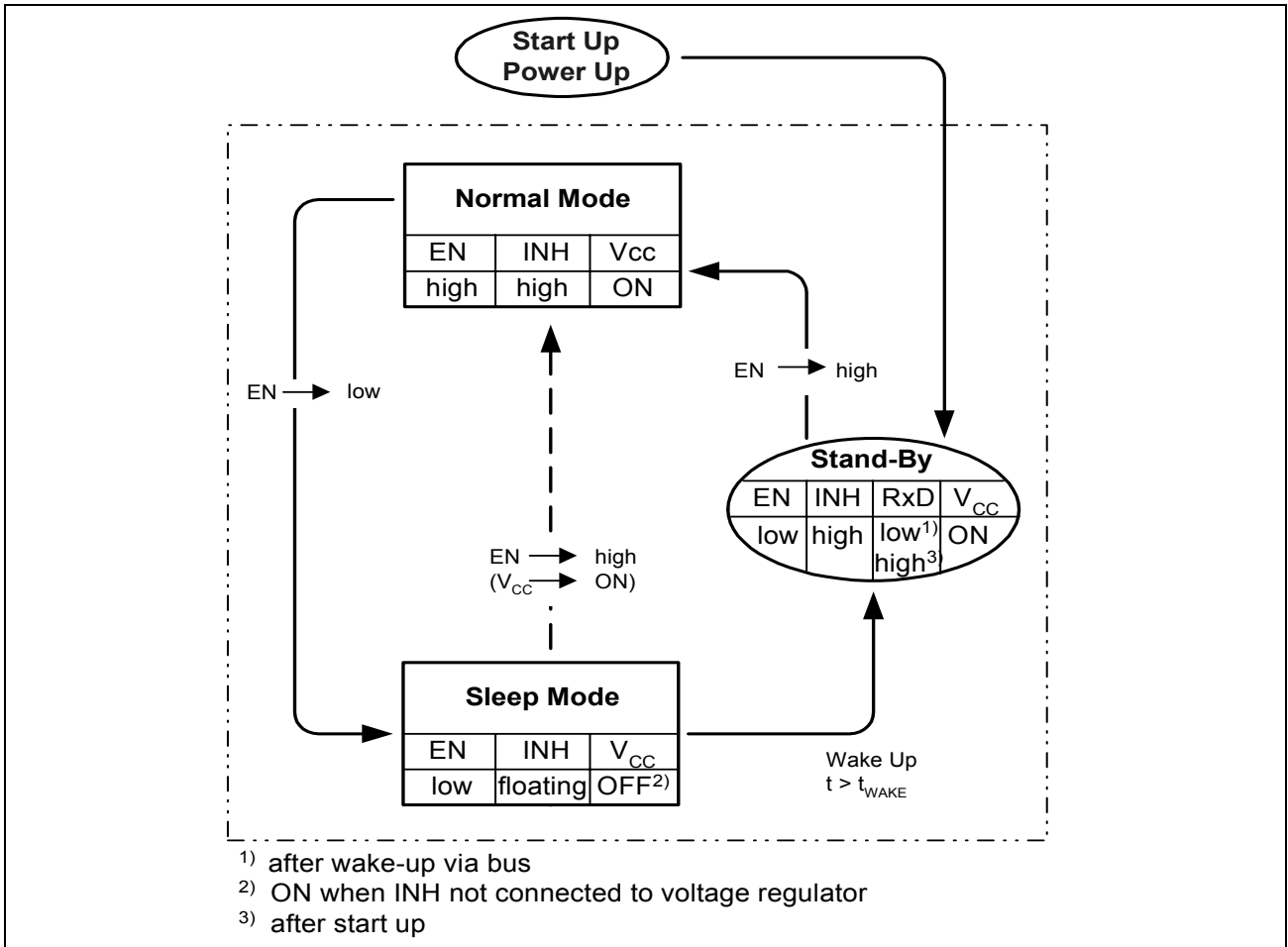

Figure 3: operation mode state diagram

Master Termination

For fail safe reasons, the TLE6259-2 already has a pull up resistor of 30kΩ implemented. To achieve the required timings for the dominant to recessive transition of the bus signal an additional external termination resistor of 1kΩ is required. It is recommended to place this resistor in the master node. To avoid reverse currents from the bus line into the battery supply line in case of an unpowered node, it is recommended to place a diode in series to the external pull up. For small systems (low bus capacitance) the EMC performance of the system is supported by an additional capacitor of at least 1nF in the master node (see figure 6 and 7, application circuit).

External Capacitors

An capacitor of 22μF at the supply voltage input V_S buffers the input voltage. In combination with the required reverse polarity diode this prevents the device from detecting power down conditions in case of negative transients on the supply line.

The 100nF capacitors close to the V_S pins of the 6259-2 and the voltage regulator help to improve the EMC behavior of the system.

Sleep Mode

In order to reduce the current consumption the TLE 6259-2 offers a sleep operation mode. This mode is selected by switching the enable input EN low (see figure 3, state diagram). In the sleep mode, a voltage regulator can be controlled via the INH output in order to minimize the current consumption of the whole application. A wake-up caused by a message on the communication bus, automatically enables the voltage regulator by switching the INH output high. In parallel the wake-up is indicated by setting the RxD output LOW. When entering the normal mode this wake-up flag is reset and the RxD output is released to transmit the bus data.

In case the voltage regulator control input is not connected to INH output or the microcontroller is active respectively, the TLE6259-2 can be set in normal operation mode without a wake-up via the communication bus.

Bus Short to GND Feature

The TLE6259-2 also has a BUS short to GND feature implemented, in order to protect the battery from running out of charge. A normal master termination connection like described above, 1k Ω resistor and diode between bus and V_S , would cause a constantly drawn current via this path. The resulting resistance of this short to GND is lower than 1k Ω . To avoid this current during a generator off state, like a parked car, the sleep mode has a bus short to GND feature implemented in the 6259-2. This feature is only applicable, if the master termination is connected with the INH pin, instead of the V_S . For a more detailed information see the application circuit in figure 6 and 7.

2 Electrical Characteristics

2.1 Absolute Maximum Ratings

Parameter	Symbol	Limit Values		Unit	Remarks
		min.	max.		

Voltages

Supply voltage	V_{CC}	-0.3	6	V	
Battery supply voltage	V_S	-0.3	40	V	
Bus input voltage	V_{bus}	-20	32	V	
Bus input voltage	V_{bus}	-20	40	V	$t < 1s$
Logic voltages at EN, TxD, RxD	V_I	-0.3	$V_{CC} + 0.3$	V	$0 V < V_{CC} < 5.5 V$
Input voltages at INH	V_{INH}	-0.3	$V_S + 0.3$	V	
Output current at INH	I_{INH}		20	mA	
Electrostatic discharge voltage at Vs, Bus	V_{ESD}	-4	4	kV	human body model (100 pF via 1.5 kΩ)
Electrostatic discharge voltage	V_{ESD}	-2	2	kV	human body model (100 pF via 1.5 kΩ)
Temperatures					
Junction temperature	T_j	-40	150	°C	–

Note: Maximum ratings are absolute ratings; exceeding any one of these values may cause irreversible damage to the integrated circuit.

2.2 Operating Range

Parameter	Symbol	Limit Values		Unit	Remarks
		min.	max.		
Supply voltage	V_{CC}	4.5	5.5	V	
Battery Supply Voltage	V_S	6	35	V	
Junction temperature	T_j	- 40	150	°C	-

Thermal Resistances

Junction ambient	R_{thj-a}	-	185	K/W	-
------------------	-------------	---	-----	-----	---

Thermal Shutdown (junction temperature)

	Symbol	Limit Values			Unit
		min.	typ.	max.	
Thermal shutdown temp.	T_{jSD}	150	170	190	°C
Thermal shutdown hyst.	ΔT	-	10	-	K

2.3 Electrical Characteristics

4.5 V < V_{CC} < 5.5 V; 6.0 V < V_S < 27 V; $R_L = 500 \Omega$; $V_{EN} > V_{EN,ON}$; $-40 \text{ }^\circ\text{C} < T_j < 125 \text{ }^\circ\text{C}$; all voltages with respect to ground; positive current flowing into pin; unless otherwise specified.

Parameter	Symbol	Limit Values			Unit	Remarks
		min.	typ.	max.		

Current Consumption

Current consumption in Normal Mode	I_{CC}		0.3	0,7	mA	recessive state; $V_{TxD} = V_{CC}$
			0.4	0.8	mA	dominant state; $V_{TxD} = 0 \text{ V}$
	I_S		0.8	1.5	mA	recessive state, without R_{load} ; $V_{TxD} = V_{CC}$
			1.3	2	mA	dominant state, without R_{load} ; $V_{TxD} = 0 \text{ V}$
Current consumption in Standby Mode	I_{CC}		3	10	μA	external VR activated INH=H
	I_S		18	30	μA	
Current consumption in Sleep Mode	I_{CC}		-	-	μA	external VR deactivated INH=L
	I_S		18	30	μA	

2.3 Electrical Characteristics (cont'd)

4.5 V < V_{CC} < 5.5 V; 6.0 V < V_S < 27 V; R_L = 500 Ω; V_{EN} > V_{EN,ON}; -40 °C < T_j < 125 °C; all voltages with respect to ground; positive current flowing into pin; unless otherwise specified.

Parameter	Symbol	Limit Values			Unit	Remarks
		min.	typ.	max.		

Receiver Output R×D

HIGH level output current	I _{RD,H}	-1.2	-0.8	-0.5	mA	V _{RD} = 0.8 × V _{CC} ,
LOW level output current	I _{RD,L}	0.5	0.8	1.2	mA	V _{RD} = 0.2 × V _{CC} ,

Transmission Input T×D

HIGH level input voltage threshold	V _{TD,H}		2.9	0.7 × V _{CC}	V	recessive state
TxD input hysteresis	V _{TD,hys}	300	700	900	mV	
LOW level input voltage threshold	V _{TD,L}	0.3 × V _{CC}	2.1		V	dominant state
TxD pull up current	I _{TD}	-150	-110	-70	μA	V _{TxD} < 0.3V _{CC}

Enable input (pin EN)

HIGH level input voltage threshold	V _{EN,on}		2.8	0.7 × V _{CC}	V	normal mode
LOW level input voltage threshold	V _{EN,off}	0.3 × V _{CC}	2.2		V	low power mode
EN input hysteresis	V _{EN,hys}	300	600	900	mV	
EN pull down resistance	R _{EN}	15	30	60	kΩ	

Inhibit output (pin INH)

Inhibit R _{on} resistance	R _{onINH}		65	120	Ω	I _{INH} = - 15 mA
Leakage current	I _{INH,lk}	- 5.0		5.0	μA	sleep mode; V _{INH} = 0 V

2.3 Electrical Characteristics (cont'd)

4.5 V < V_{CC} < 5.5 V; 6.0 V < V_S < 27 V; R_L = 500 Ω; V_{EN} > V_{EN,ON}; -40 °C < T_j < 125 °C; all voltages with respect to ground; positive current flowing into pin; unless otherwise specified.

Parameter	Symbol	Limit Values			Unit	Remarks
		min.	typ.	max.		

Bus receiver

Receiver threshold voltage, recessive to dominant edge	V _{bus,rd}	0.44 x V _S	0.5 x V _S		V	-8V < V _{bus} < V _{bus,dom}
Receiver threshold voltage, dominant to recessive edge	V _{bus,dr}		0.56 x V _S	0.6 x V _S	V	V _{bus,rec} < V _{bus} < 20 V
Receiver hysteresis	V _{bus,hys}	0.02 x V _S	0.04 x V _S	0.1 x V _S	mV	V _{bus,hys} = V _{bus,rec} - V _{bus,dom}
wake-up threshold voltage	V _{wake}	0.40 x V _S	0.5 x V _S	0.6 x V _S	V	

Bus transmitter

Bus recessive output voltage	V _{bus,rec}	0.9 x V _S		V _S	V	V _{TxD} = V _{CC}
Bus dominant output voltage	V _{bus,dom}			0.15 x V _S	V	V _{TxD} = 0 V; 8V < V _S < 27V
				1.2	V	6V < V _S < 8V
Bus short circuit current	I _{bus,sc}	40	100	150	mA	V _{bus,short} = 13.5 V
Leakage current	I _{bus,lk}	-150	-70		μA	V _{CC} = 0 V, V _S = 0 V, V _{bus} = -8 V
			10	25	μA	V _{CC} = 0 V, V _S = 0 V, V _{bus} = 20 V
				10	μA	V _{LIN} = V _S = 13.5V
Bus pull up resistance	R _{bus}	20	30	47	kΩ	Normal mode
Lin output current	I _{lin}	5	30	60	μA	Sleep mode

2.3 Electrical Characteristics (cont'd)

4.5 V < V_{CC} < 5.5 V; 6.0 V < V_S < 27 V; R_L = 500 Ω; V_{EN} > V_{EN,ON}; -40 °C < T_j < 125 °C; all voltages with respect to ground; positive current flowing into pin; unless otherwise specified.

Parameter	Symbol	Limit Values			Unit	Remarks
		min.	typ.	max.		

Dynamic Transceiver Characteristics

Slope fall time	t _{fslope}			22,5	μs	100% > V _{bus} > 0% C _{bus} = 10 nF; R _L = 500Ω V _{CC} = 5 V; V _S = 13.5 V
Slope rise time	t _{rslope}			22,5	μs	0% > V _{bus} > 10 0% C _{bus} = 10 nF; R _L = 500Ω V _{CC} = 5 V; V _S = 13.5 V
Slope symmetry	t _{slopesym}	-5		5	μs	t _{fslope} - t _{rslope}
Slope fall time	t _{fslope}			22.5	μs	100% > V _{bus} > 0% C _{bus} = 6,8nF; R _L = 660Ω T _{ambient} < 85 °C; V _{CC} = 5 V; V _S = 13.5 V
Slope rise time	t _{rslope}			22.5	μs	0% > V _{bus} > 100% C _{bus} = 6,8nF; R _L = 660Ω V _{CC} = 5 V; V _S = 13.5 V
Slope symmetry	t _{slopesym}	-4		4	μs	t _{fslope} - t _{rslope}
Propagation delay TxD LOW to bus	t _{d(L),T}		1	3	μs	V _{CC} = 5 V
Propagation delay TxD HIGH to bus	t _{d(H),T}		1	3	μs	V _{CC} = 5 V
Propagation delay bus dominant to RxD LOW	t _{d(L),R}		1	6	μs	V _{CC} = 5V; C _{RxD} = 20pF
Propagation delay bus recessive to RxD HIGH	t _{d(H),R}		1	6	μs	V _{CC} = 5 V; C _{RxD} = 20 pF
Receiver delay symmetry	t _{sym,R}	-2		2	μs	t _{sym,R} = t _{d(L),R} - t _{d(H),R}
Transmitter delay symmetry	t _{sym,T}	-2		2	μs	t _{sym,T} = t _{d(L),T} - t _{d(H),T}
Wake-up delay time	t _{wake}	30	100	150	μs	T _j ≤ 125°
				170	μs	T _j ≤ 150°
Delay time for change sleep/ stand by mode-normal mode	t _{snorm}			10	μs	
Delay time for change normal mode - sleep mode	t _{nsleep}			10	μs	

3 Diagrams

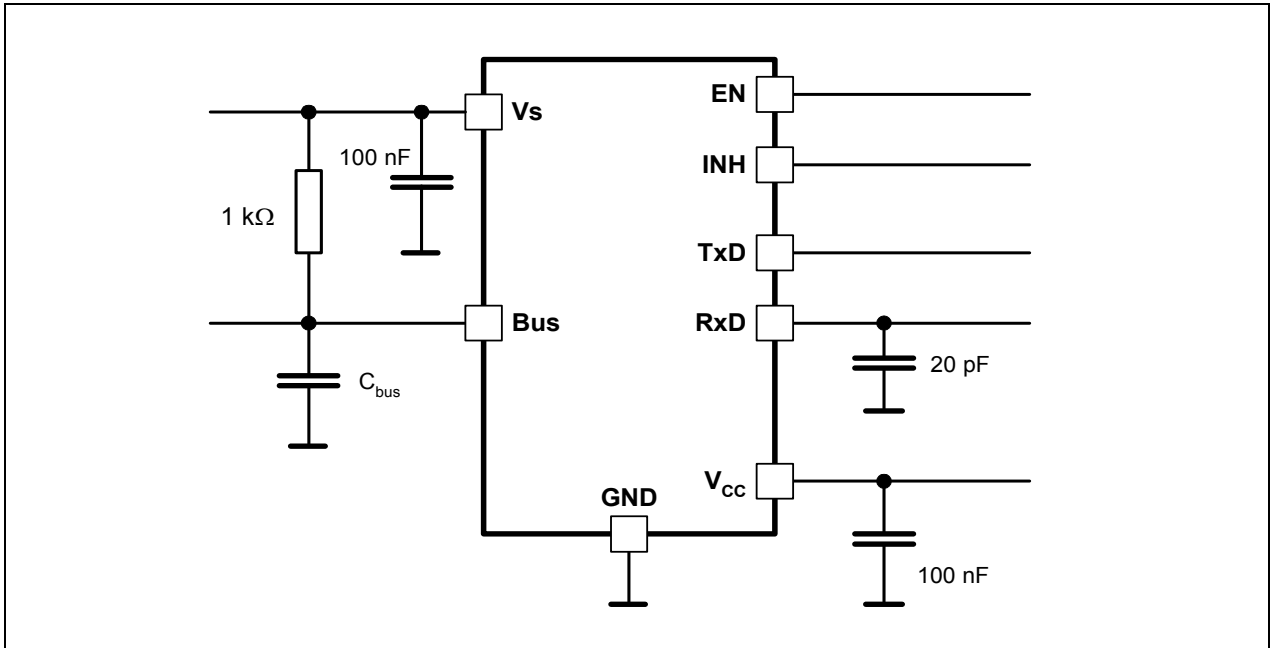

Figure 4: Test circuits

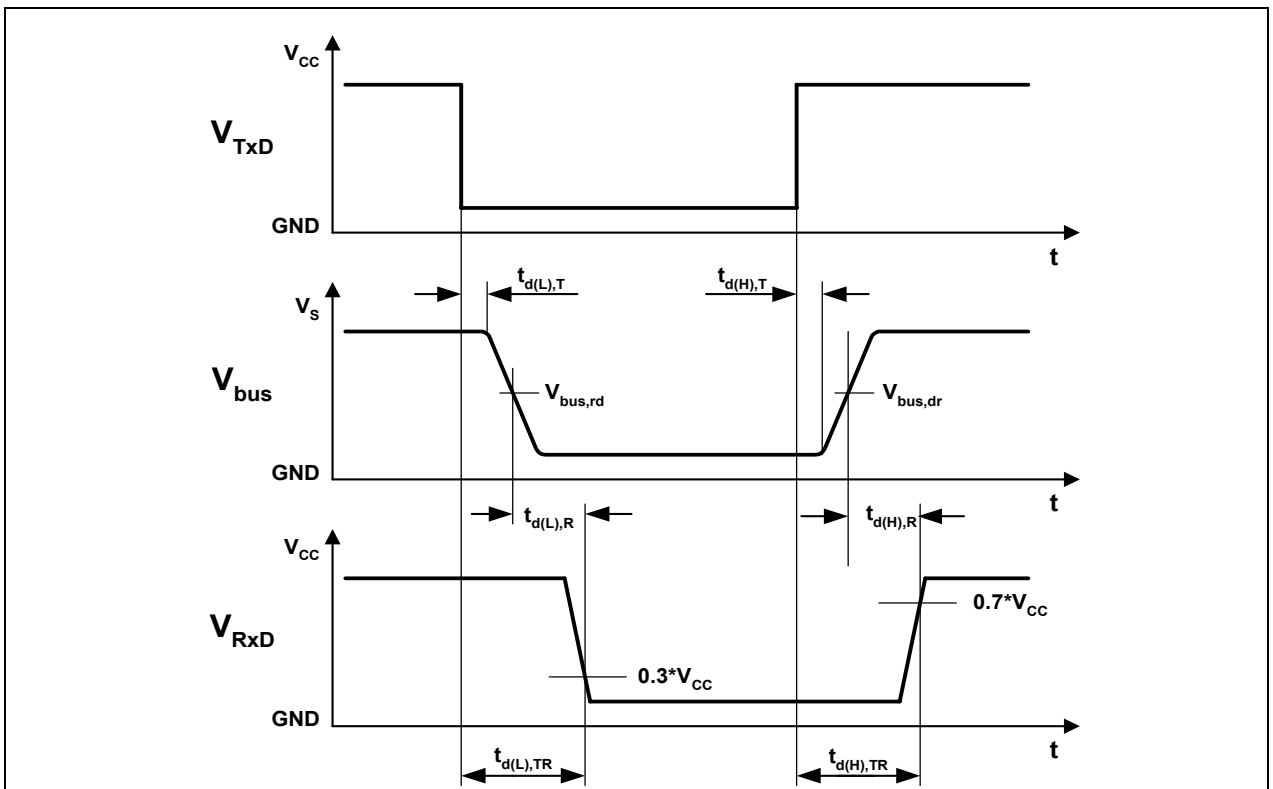

Figure 5: Timing diagrams for dynamic characteristics

4 Application

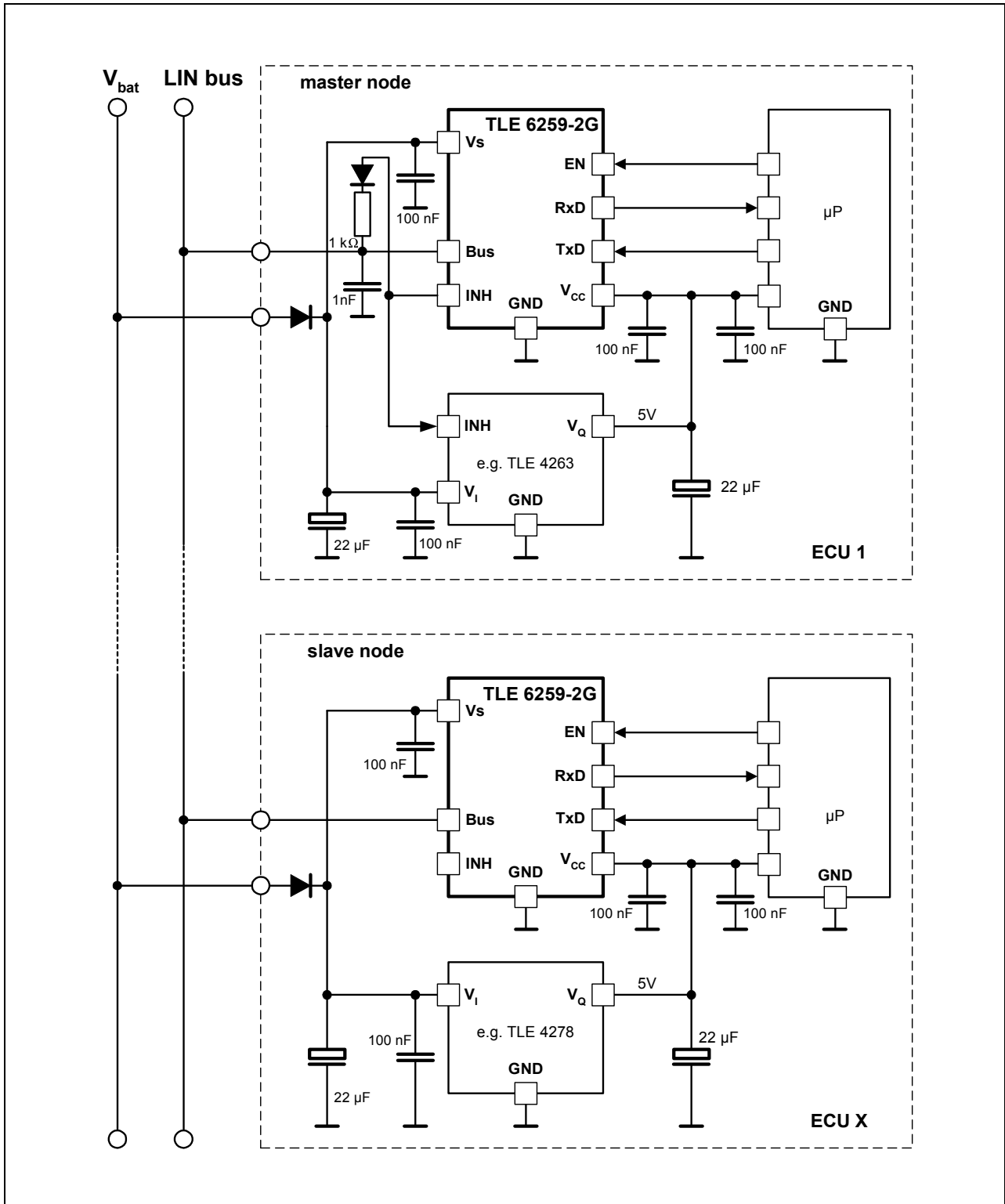

Figure 6
Application circuit with bus short to GND feature applied

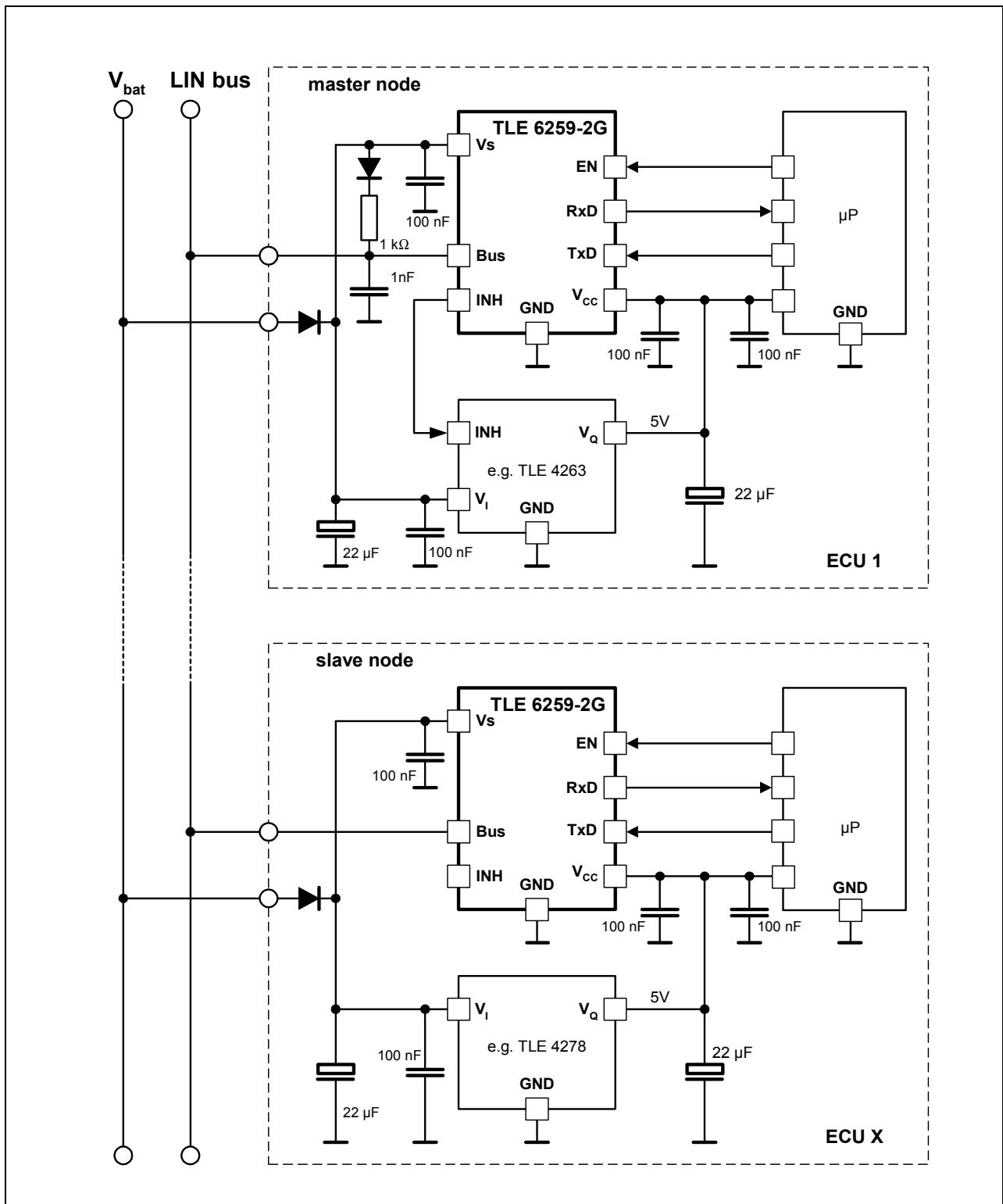
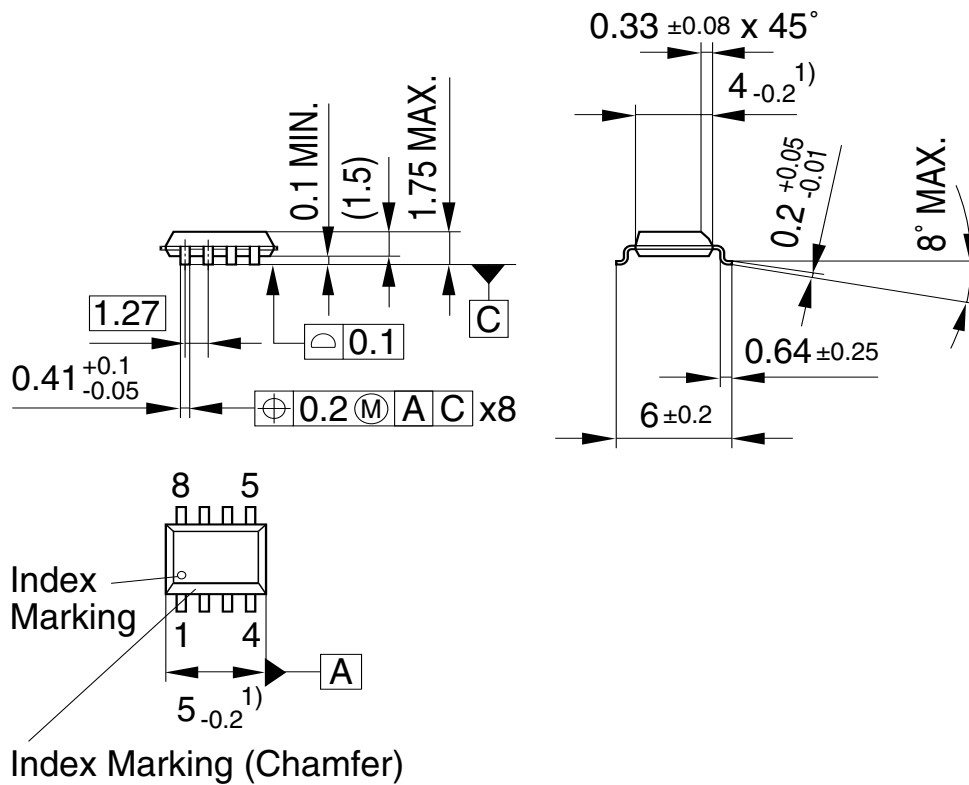

Figure 7
Application circuit without bus short to GND feature

5 Package Outlines

P-DSO-8-3

(Plastic Dual Small Outline Package)



¹⁾ Does not include plastic or metal protrusion of 0.15 max. per side

Sorts of Packing

Package outlines for tubes, trays etc. are contained in our Data Book "Package Information".

SMD = Surface Mounted Device

Dimensions in mm

Edition 1999-10-12

Published by Infineon Technologies AG

St.-Martin-Strasse 53

D-81541 München

© Infineon Technologies AG1999

All Rights Reserved.

Attention please!

The information herein is given to describe certain components and shall not be considered as warranted characteristics.

Terms of delivery and rights to technical change reserved.

We hereby disclaim any and all warranties, including but not limited to warranties of non-infringement, regarding circuits, descriptions and charts stated herein.

Infineon Technologies is an approved CECC manufacturer.

Information

For further information on technology, delivery terms and conditions and prices please contact your nearest Infineon Technologies Office in Germany or our Infineon Technologies Representatives worldwide (see address list).

Warnings

Due to technical requirements components may contain dangerous substances. For information on the types in question please contact your nearest Infineon Technologies Office.

Infineon Technologies Components may only be used in life-support devices or systems with the express written approval of Infineon Technologies, if a failure of such components can reasonably be expected to cause the failure of that life-support device or system, or to affect the safety or effectiveness of that device or system. Life support devices or systems are intended to be implanted in the human body, or to support and/or maintain and sustain and/or protect human life. If they fail, it is reasonable to assume that the health of the user or other persons may be endangered.

Infineon goes for Business Excellence

“Business excellence means intelligent approaches and clearly defined processes, which are both constantly under review and ultimately lead to good operating results.

Better operating results and business excellence mean less idleness and wastefulness for all of us, more professional success, more accurate information, a better overview and, thereby, less frustration and more satisfaction.”

Dr. Ulrich Schumacher

<http://www.infineon.com>

Published by Infineon Technologies AG