

阅读申明

- 1.本站收集的数据手册和产品资料都来自互联网，版权归原作者所有。如读者和版权方有任何异议请及时告之，我们将妥善解决。
- 2.本站提供的中文数据手册是英文数据手册的中文翻译，其目的是协助用户阅读，该译文无法自动跟随原稿更新，同时也可能存在翻译上的不当。建议读者以英文原稿为参考以便获得更精准的信息。
- 3.本站提供的产品资料，来自厂商的技术支持或者使用者的心得体会等，其内容可能存在描述上的差异，建议读者做出适当判断。
- 4.如需与我们联系，请发邮件到marketing@iczoom.com，主题请标有“数据手册”字样。

Read Statement

1. The datasheets and other product information on the site are all from network reference or other public materials, and the copyright belongs to the original author and original published source. If readers and copyright owners have any objections, please contact us and we will deal with it in a timely manner.
2. The Chinese datasheets provided on the website is a Chinese translation of the English datasheets. Its purpose is for reader's learning exchange only and do not involve commercial purposes. The translation cannot be automatically updated with the original manuscript, and there may also be improper translations. Readers are advised to use the English manuscript as a reference for more accurate information.
3. All product information provided on the website refer to solutions from manufacturers' technical support or users the contents may have differences in description, and readers are advised to take the original article as the standard.
4. If you have any questions, please contact us at marketing@iczoom.com and mark the subject with "Datasheets" .



ST3232E

±15KV ESD-PROTECTED, 3 TO 5.5V, LOW POWER, UP TO 250KBPS, RS-232 DRIVERS AND RECEIVERS

- ESD PROTECTION FOR RS-232 I/O PINS
±15KV HUMAN BODY MODEL
±8KV IEC 1000-4-2 CONTACT DISCHARGE
- 300µA SUPPLY CURRENT
- 250Kbps MINIMUM GUARENTEED DATA RATE
- 6V/µs MINIMUM GUARANTEED SLEW RATE
- MEET EIA/TIA-232 SPECIFICATIONS DOWN TO 3V
- AVAILABLE IN DIP-16, SO-16, SO-16 LARGE AND TSSOP16

DESCRIPTION

The ST3232E is a 3V powered EIA/TIA-232 and V.28/V.24 communication interfaces with low power requirements, high data-rate capabilities and enhanced electrostatic discharge (ESD) protection to ±8kV using IEC1000-4-2 Contact Discharge and ±15kV using the Human Body Model. ST3232E has a proprietary low dropout transmitter output stage providing true RS-232 performance from 3 to 5V supplies with a dual charge pump. The charge pump requires only four small 0.1µF standard external capacitors for operations from 3V supply.

The ST3232E has two receivers and two drivers.

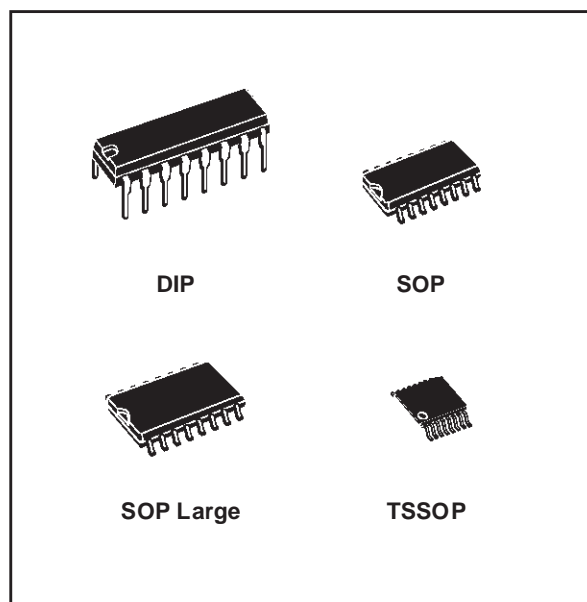

The device is guaranteed to run at data rates of 250Kbps while maintaining RS-232 output levels. Typical applications are Notebook, Subnotebook and Palmtop Computers, Battery Powered Equipment, Hand-Held Equipment, Peripherals and Printers.

ORDERING CODES

Type	Temperature Range	Package	Comments
ST3232ECN	0 to 70 °C	DIP-16	25parts per tube / 40tube per box
ST3232EBN	-40 to 85 °C	DIP-16	25parts per tube / 40tube per box
ST3232ECD	0 to 70 °C	SO-16 (Tube)	50parts per tube / 20tube per box
ST3232EBD	-40 to 85 °C	SO-16 (Tube)	50parts per tube / 20tube per box
ST3232ECDR	0 to 70 °C	SO-16 (Tape & Reel)	2500 parts per reel
ST3232EBDR	-40 to 85 °C	SO-16 (Tape & Reel)	2500 parts per reel
ST3232ECW	0 to 70 °C	SO-16 Large (Tube)	50parts per tube / 20tube per box
ST3232EBW	-40 to 85 °C	SO-16 Large (Tube)	50parts per tube / 20tube per box
ST3232ECWR	0 to 70 °C	SO-16 Large (Tape & Reel)	1000 parts per reel
ST3232EBWR	-40 to 85 °C	SO-16 Large (Tape & Reel)	1000 parts per reel
ST3232ECTR	0 to 70 °C	TSSOP16 (Tape & Reel)	2500 parts per reel
ST3232EBTR	-40 to 85 °C	TSSOP16 (Tape & Reel)	2500 parts per reel

PIN CONFIGURATION

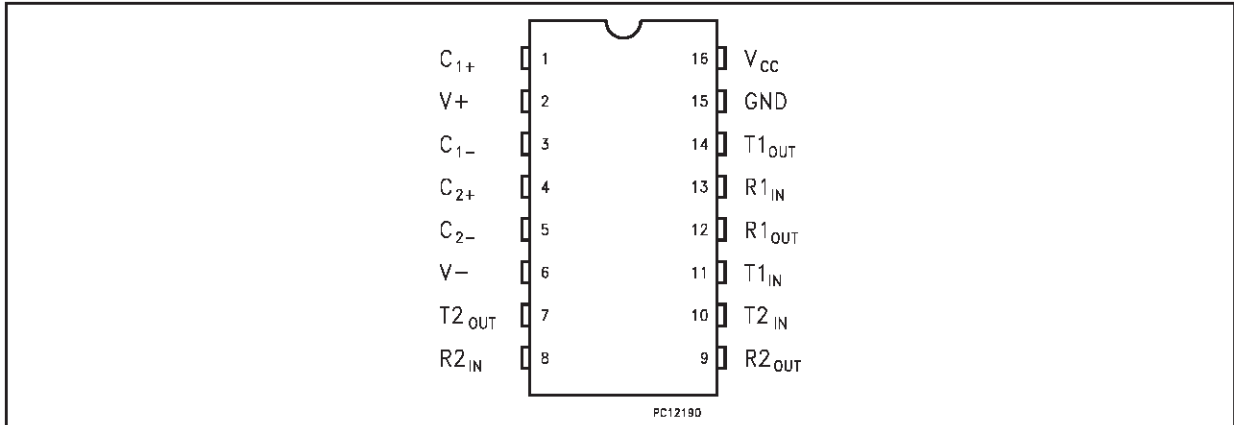

PIN DESCRIPTION

PIN N°	SYMBOL	NAME AND FUNCTION
1	C ₁₊	Positive Terminal for the first Charge Pump Capacitor
2	V+	Doubled Voltage Terminal
3	C ₁₋	Negative Terminal for the first Charge Pump Capacitor
4	C ₂₊	Positive Terminal for the second Charge Pump Capacitor
5	C ₂₋	Negative Terminal for the second Charge Pump Capacitor
6	V-	Inverted Voltage Terminal
7	T _{2_OUT}	Second Transmitter Output Voltage
8	R _{2_IN}	Second Receiver Input Voltage
9	R _{2_OUT}	Second Receiver Output Voltage
10	T _{2_IN}	Second Transmitter Input Voltage
11	T _{1_IN}	First Transmitter Input Voltage
12	R _{1_OUT}	First Receiver Output Voltage
13	R _{1_IN}	First Receiver Input Voltage
14	T _{1_OUT}	First Transmitter Output Voltage
15	GND	Ground
16	V _{CC}	Supply Voltage

ABSOLUTE MAXIMUM RATINGS

Symbol	Parameter	Value	Unit
V _{CC}	Supply Voltage	-0.3 to 6	V
V+	Doubled Voltage Terminal	(V _{CC} - 0.3) to 7	V
V-	Inverted Voltage Terminal	0.3 to -7	V
V+ + V-		13	V
T _{IN}	Transmitter Input Voltage Range	-0.3 to 6	V
R _{IN}	Receiver Input Voltage Range	± 25	V
T _{OUT}	Transmitter Output Voltage Range	± 13.2	V
R _{OUT}	Receiver Output Voltage Range	-0.3 to (V _{CC} + 0.3)	V
t _{SHORT}	Transmitter Output Short to GND Time	Continuous	

Absolute Maximum Ratings are those values beyond which damage to the device may occur. Functional operation under these condition is not implied. V+ and V- can have a maximum magnitude of +7V, but their absolute addition can not exceed 13 V.

ESD PERFORMANCE: TRANSMITTER OUTPUTS, RECEIVER INPUTS

Symbol	Parameter	Test Conditions	Min.	Typ.	Max.	Unit
ESD	ESD Protection Voltage	Human Body Model	±15			kV
ESD	ESD Protection Voltage	IEC-1000-4-2	±8			kV

ELECTRICAL CHARACTERISTICS

($C_1 - C_4 = 0.1\mu\text{F}$, $V_{CC} = 3\text{V}$ to 5.5V , $T_A = -40$ to 85°C , unless otherwise specified.

Typical values are referred to $T_A = 25^\circ\text{C}$)

Symbol	Parameter	Test Conditions	Min.	Typ.	Max.	Unit
I_{SUPPLY}	V_{CC} Power Supply Current	No Load $V_{CC} = 3\text{V}$ or 5V $T_A = 25^\circ\text{C}$		0.3	1	mA

LOGIC INPUT ELECTRICAL CHARACTERISTICS

($C_1 - C_4 = 0.1\mu\text{F}$, $V_{CC} = 3\text{V}$ to 5.5V , $T_A = -40$ to 85°C , unless otherwise specified.

Typical values are referred to $T_A = 25^\circ\text{C}$)

Symbol	Parameter	Test Conditions	Min.	Typ.	Max.	Unit
V_{TIL}	Input Logic Threshold Low	T-IN			0.8	V
V_{HYS}	Transmitter Input Histeresys			0.25		V
V_{TIH}	Input Logic Threshold High	$V_{CC} = 3.3\text{V}$	2			V
		$V_{CC} = 5\text{V}$	2.4			
I_{IL}	Input Leakage Current	T-IN		±0.01	±1	μA

TRANSMITTER ELECTRICAL CHARACTERISTICS

($C_1 - C_4 = 0.1\mu\text{F}$ tested at $V_{CC} = 3\text{V}$ to 5.5V , $T_A = -40$ to 85°C , unless otherwise specified.

Typical values are referred to $T_A = 25^\circ\text{C}$)

Symbol	Parameter	Test Conditions	Min.	Typ.	Max.	Unit
V_{TOUT}	Output Voltage Swing	All Transmitter outputs are loaded with $3\text{K}\Omega$ to GND	±5	±5.4		V
R_{TOUT}	Transmitter Output Resistance	$V_{CC} = V_+ = V_- = 0\text{V}$ $V_{\text{OUT}} = \pm 2\text{V}$	300	10M		Ω
I_{TSC}	Output Short Circuit Current			±60		mA
I_{TOL}	Output Leakage Current	$V_{CC} = 0\text{V}$ or 3V to 5.5V $V_{\text{OUT}} = \pm 12\text{V}$ Transmitters Disable			±25	μA

RECEIVER ELECTRICAL CHARACTERISTICS

($C_1 - C_4 = 0.1\mu\text{F}$ tested at $V_{CC} = 3\text{V}$ to 5.5V , $T_A = -40$ to 85°C , unless otherwise specified.
Typical values are referred to $T_A = 25^\circ\text{C}$)

Symbol	Parameter	Test Conditions	Min.	Typ.	Max.	Unit
V_{RIN}	Receiver Input Voltage Operating Range		-25		25	V
V_{RIL}	RS-232 Input Threshold Low	$T_A = 25^\circ\text{C}$ $V_{CC} = 3.3\text{V}$	0.6	1.1		V
		$T_A = 25^\circ\text{C}$ $V_{CC} = 5\text{V}$	0.8	1.5		
V_{RIH}	RS-232 Input Threshold High	$T_A = 25^\circ\text{C}$ $V_{CC} = 3.3\text{V}$		1.4	2.4	V
		$T_A = 25^\circ\text{C}$ $V_{CC} = 5\text{V}$		1.8	2.4	
V_{RIHYS}	Input Hysteresis			0.5		V
R_{RIN}	Input Resistance	$T_A = 25^\circ\text{C}$	3	5	7	$\text{K}\Omega$
V_{ROL}	TTL/CMOS Output Voltage Low	$I_{OUT} = 1.6\text{mA}$			0.4	V
V_{ROH}	TTL/CMOS Output Voltage High	$I_{OUT} = -1\text{mA}$	$V_{CC}-0.6$	$V_{CC}-0.1$		V

TIMING CHARACTERISTICS

($C_1 - C_4 = 0.1\mu\text{F}$, $V_{CC} = 3\text{V}$ to 5.5V , $T_A = -40$ to 85°C , unless otherwise specified.
Typical values are referred to $T_A = 25^\circ\text{C}$)

Symbol	Parameter	Test Conditions	Min.	Typ.	Max.	Unit
D_R	Data Transfer Rate	$R_L = 3\text{K}\Omega$ $C_{L2} = 1000\text{pF}$ one transmitter switching	250			Kbps
t_{PHLR} t_{PLHR}	Propagation Delay Input to Output	$R_{XIN} = R_{XOUT}$ $C_L = 150\text{pF}$		0.15		μs
t_{OER}	Receiver Output Enable Time	Normal Operation		50		ns
t_{ODR}	Receiver Output Disable Time	Normal Operation		50		ns
$ t_{PHLT} - t_{THL} $	Transmitter Propagation Delay Difference	(Note 1)		200		ns
$ t_{PHLR} - t_{THR} $	Receiver Propagation Delay Difference			50		ns
S_{RT}	Transition Slew Rate	$T_A = 25^\circ\text{C}$ $R_L = 3\text{K}\Omega$ to $7\text{K}\Omega$ $V_{CC} = 3.3\text{V}$ measured from $+3\text{V}$ to -3V or -3V to $+3\text{V}$ $C_L = 150\text{pF}$ to 1000pF	6		30	$\text{V}/\mu\text{s}$
		$C_L = 150\text{pF}$ to 2500pF	4		30	$\text{V}/\mu\text{s}$

Transmitter Skew is measured at the transmitter zero cross points

APPLICATION CIRCUITS

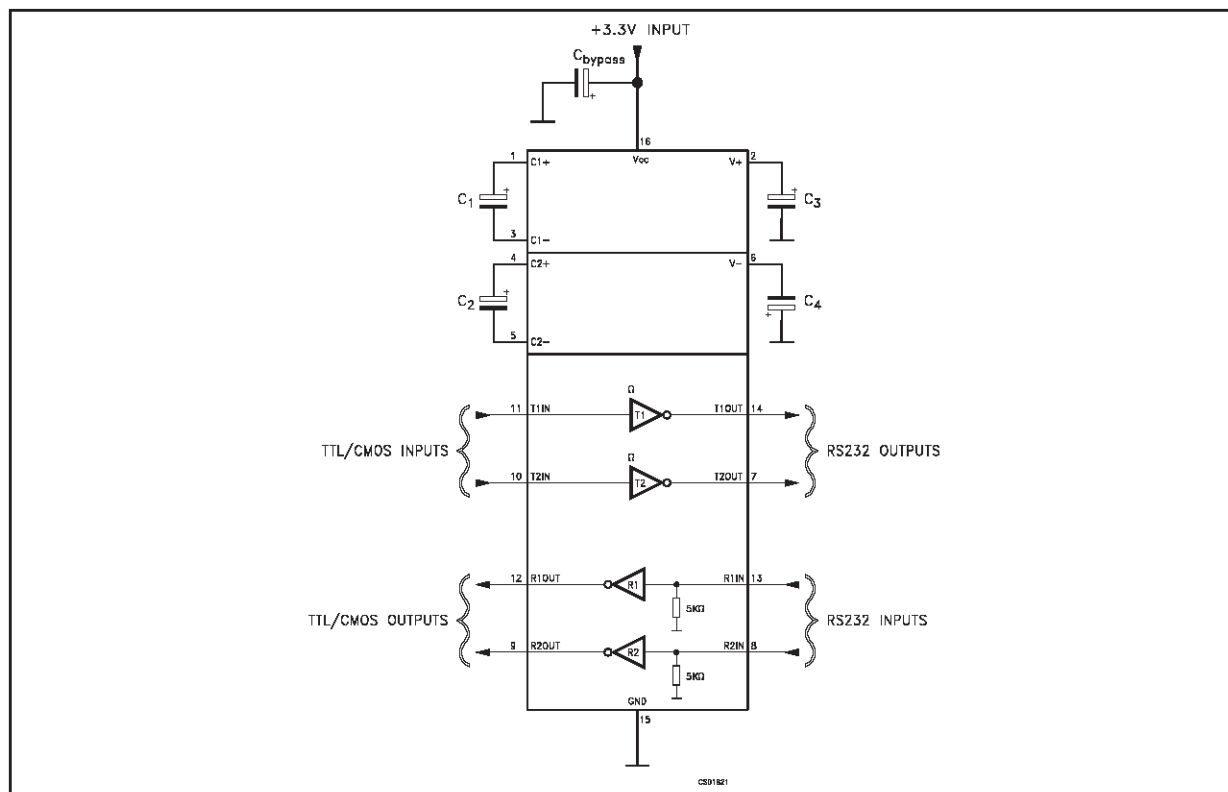

CAPACITANCE VALUE (μF)

V _{CC}	C1	C2	C3	C4	C _{bypass}
3.0 to 3.6	0.1	0.1	0.1	0.1	0.1
4.5 to 5.5	0.047	0.33	0.33	0.33	0.1
3.0 to 5.5	0.1	0.47	0.47	0.47	0.1

TYPICAL PERFORMANCE CHARACTERISTICS (unless otherwise specified $T_j = 25^\circ\text{C}$)

Figure 1 : Output Current vs Output High Voltage

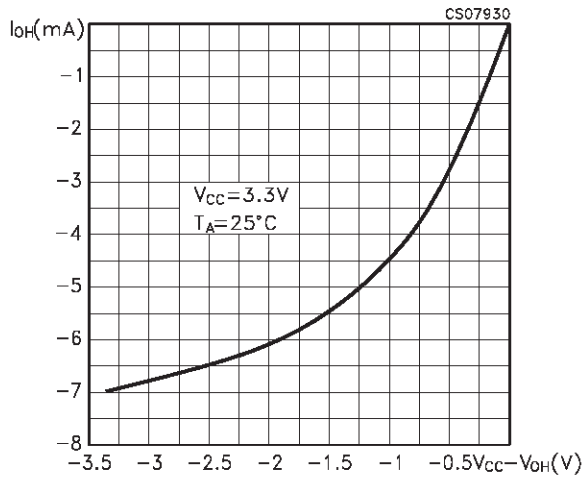

Figure 4 : Output Current vs Output Low Voltage

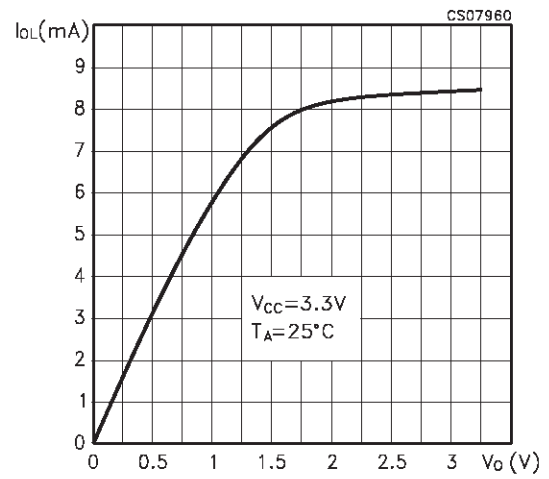

Figure 2 : Output Current vs Output High Voltage

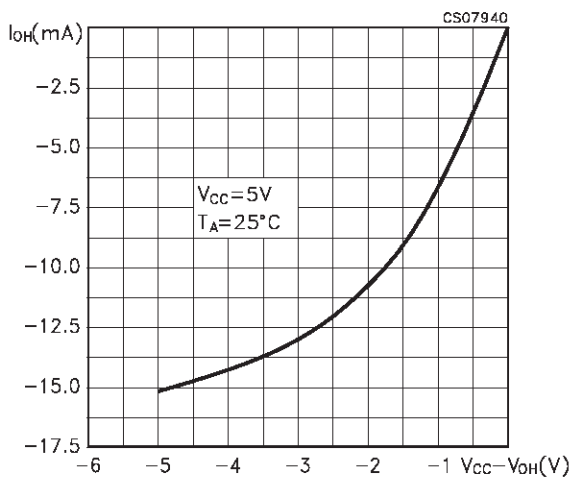

Figure 5 : Voltage Transfer Characteristics for Transmitter Inputs

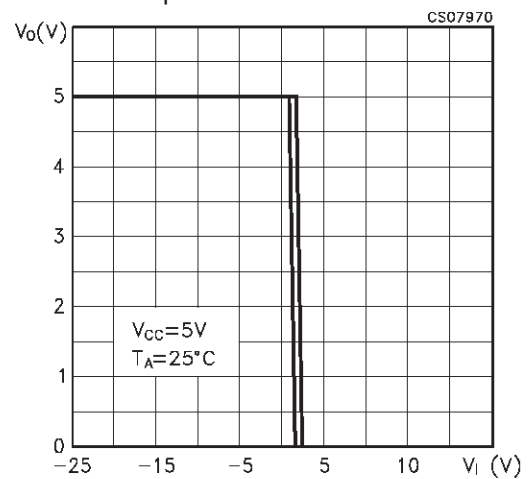

Figure 3 : Output Current vs Output Low Voltage

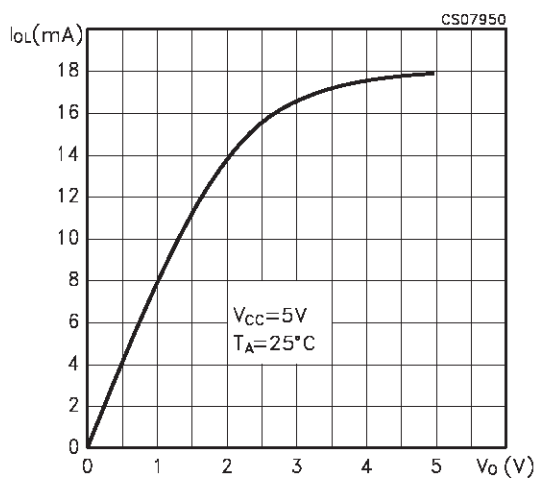
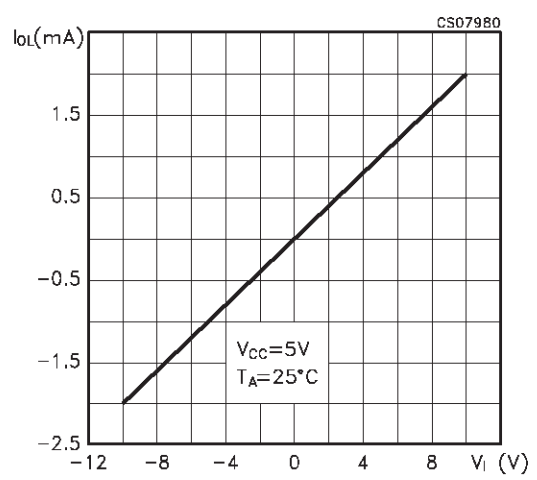
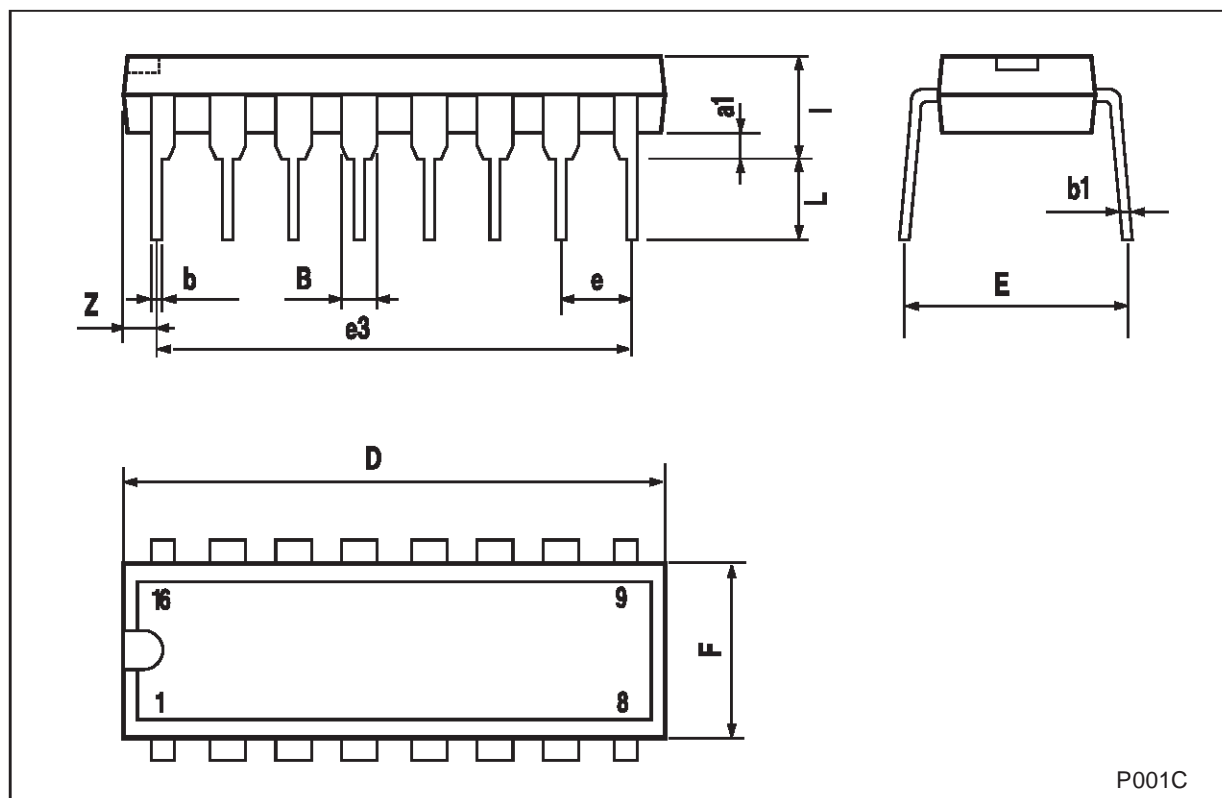

Figure 6 : Receiver Input Resistance



Plastic DIP-16 (0.25) MECHANICAL DATA

DIM.	mm.			inch		
	MIN.	TYP	MAX.	MIN.	TYP.	MAX.
a1	0.51			0.020		
B	0.77		1.65	0.030		0.065
b		0.5			0.020	
b1		0.25			0.010	
D			20			0.787
E		8.5			0.335	
e		2.54			0.100	
e3		17.78			0.700	
F			7.1			0.280
I			5.1			0.201
L		3.3			0.130	
Z			1.27			0.050



SO-16 MECHANICAL DATA

DIM.	mm.			inch		
	MIN.	TYP.	MAX.	MIN.	TYP.	MAX.
A			1.75			0.068
a1	0.1		0.2	0.003		0.007
a2			1.65			0.064
b	0.35		0.46	0.013		0.018
b1	0.19		0.25	0.007		0.010
C		0.5			0.019	
c1	45° (typ.)					
D	9.8		10	0.385		0.393
E	5.8		6.2	0.228		0.244
e		1.27			0.050	
e3		8.89			0.350	
F	3.8		4.0	0.149		0.157
G	4.6		5.3	0.181		0.208
L	0.5		1.27	0.019		0.050
M			0.62			0.024
S	8° (max.)					

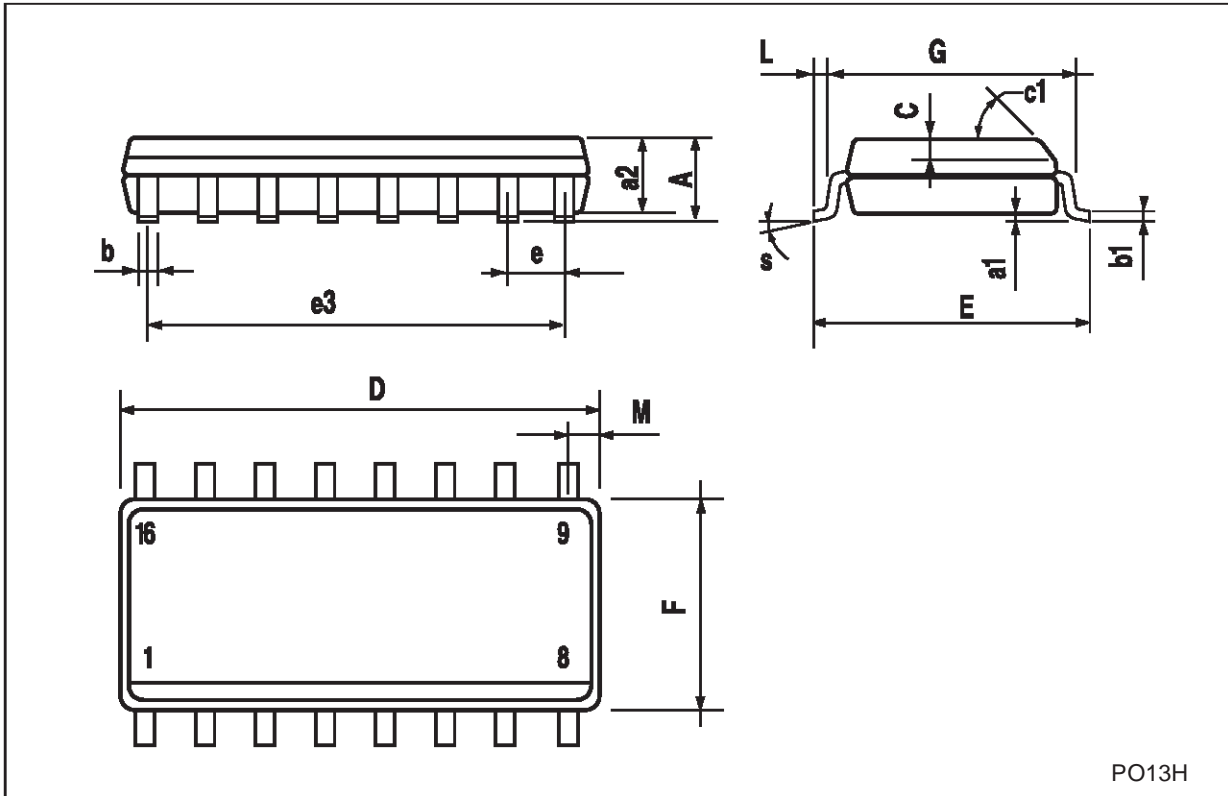

PO13H

SO-16L MECHANICAL DATA

DIM.	mm.			inch		
	MIN.	TYP.	MAX.	MIN.	TYP.	MAX.
A			2.65			0.104
a1	0.1		0.2	0.004		0.008
a2			2.45			0.096
b	0.35		0.49	0.014		0.019
b1	0.23		0.32	0.009		0.012
C		0.5			0.020	
c1	45° (typ.)					
D	10.1		10.5	0.397		0.413
E	10.0		10.65	0.393		0.419
e		1.27			0.050	
e3		8.89			0.350	
F	7.4		7.6	0.291		0.300
G						
L	0.5		1.27	0.020		0.050
M			0.75			0.029
S	8° (max.)					

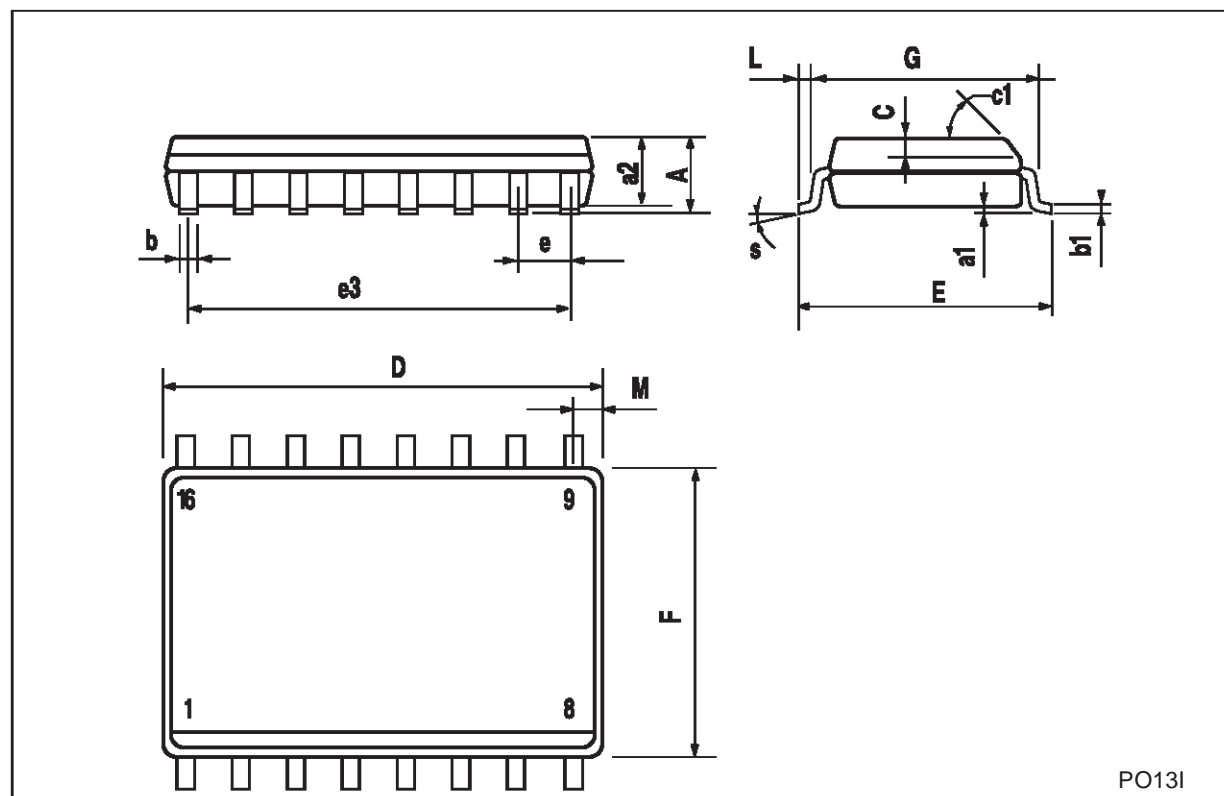

PO131

TSSOP16 MECHANICAL DATA

DIM.	mm.			inch		
	MIN.	TYP	MAX.	MIN.	TYP.	MAX.
A			1.2			0.047
A1	0.05		0.15	0.002	0.004	0.006
A2	0.8	1	1.05	0.031	0.039	0.041
b	0.19		0.30	0.007		0.012
c	0.09		0.20	0.004		0.0089
D	4.9	5	5.1	0.193	0.197	0.201
E	6.2	6.4	6.6	0.244	0.252	0.260
E1	4.3	4.4	4.48	0.169	0.173	0.176
e		0.65 BSC			0.0256 BSC	
K	0°		8°	0°		8°
L	0.45	0.60	0.75	0.018	0.024	0.030

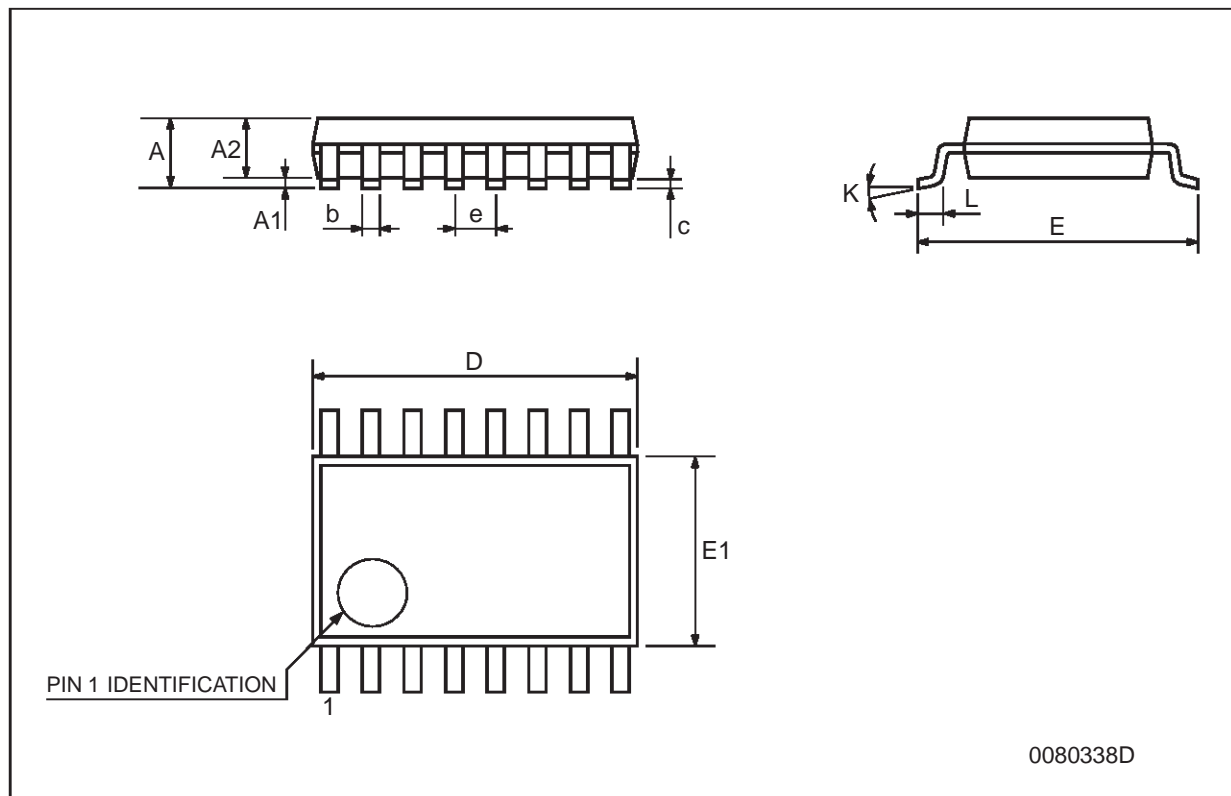

Information furnished is believed to be accurate and reliable. However, STMicroelectronics assumes no responsibility for the consequences of use of such information nor for any infringement of patents or other rights of third parties which may result from its use. No license is granted by implication or otherwise under any patent or patent rights of STMicroelectronics. Specifications mentioned in this publication are subject to change without notice. This publication supersedes and replaces all information previously supplied. STMicroelectronics products are not authorized for use as critical components in life support devices or systems without express written approval of STMicroelectronics.

© The ST logo is a registered trademark of STMicroelectronics

© 2002 STMicroelectronics - Printed in Italy - All Rights Reserved
STMicroelectronics GROUP OF COMPANIES

Australia - Brazil - Canada - China - Finland - France - Germany - Hong Kong - India - Israel - Italy - Japan - Malaysia - Malta - Morocco
Singapore - Spain - Sweden - Switzerland - United Kingdom - United States.

© <http://www.st.com>



This datasheet has been download from:

www.datasheetcatalog.com

Datasheets for electronics components.