

阅读申明

- 1.本站收集的数据手册和产品资料都来自互联网，版权归原作者所有。如读者和版权方有任何异议请及时告之，我们将妥善解决。
- 2.本站提供的中文数据手册是英文数据手册的中文翻译，其目的是协助用户阅读，该译文无法自动跟随原稿更新，同时也可能存在翻译上的不当。建议读者以英文原稿为参考以便获得更精准的信息。
- 3.本站提供的产品资料，来自厂商的技术支持或者使用者的心得体会等，其内容可能存在描述上的差异，建议读者做出适当判断。
- 4.如需与我们联系，请发邮件到marketing@iczoom.com，主题请标有“数据手册”字样。

Read Statement

1. The datasheets and other product information on the site are all from network reference or other public materials, and the copyright belongs to the original author and original published source. If readers and copyright owners have any objections, please contact us and we will deal with it in a timely manner.
2. The Chinese datasheets provided on the website is a Chinese translation of the English datasheets. Its purpose is for reader's learning exchange only and do not involve commercial purposes. The translation cannot be automatically updated with the original manuscript, and there may also be improper translations. Readers are advised to use the English manuscript as a reference for more accurate information.
3. All product information provided on the website refer to solutions from manufacturers' technical support or users the contents may have differences in description, and readers are advised to take the original article as the standard.
4. If you have any questions, please contact us at marketing@iczoom.com and mark the subject with "Datasheets" .

V320

8-Bit Registered Bus Transceiver

General Description

The V320 is an 8-bit universal bus transceiver designed for high speed interfacing with the VME320 backplane. It has output characteristics optimized for driving large capacitive loads and features modified input levels (V_{IH}/V_{IL}) for increased noise immunity and reduced input skew. The V320 functionality consists of bus transceiver circuits with 3-STATE, D-type flip-flops, and control circuitry arranged for multiplexed transmission of data directly from the input bus or from the internal registers. Data on the A or B bus will be clocked into the registers as the appropriate clock pin goes to a high logic level. \overline{OE} and direction pins are provided to control the transceiver function. In the transceiver mode, data present at the high impedance port may be stored in either the A or B register or in both. The select controls can multiplex stored and real time (transparent mode) data. The direction control determines which bus will receive data when the enable control \overline{OE} is active LOW. In the isolation mode (\overline{OE} HIGH) A data may be stored in the B register and/or B data may be stored in the A register.

Features

- Independent registers for A and B buses
- Multiplexed real-time and stored data
- Guaranteed output skew
- Guaranteed MOS (Multiple Output Switching) Specifications
- Output switching specified for both 50 pF and 250 pF, and 500 pF loads
- Guaranteed simultaneous switching noise level (V_{OLP}/V_{OLV}) and dynamic threshold performance (V_{IHD}/V_{ILD})
- Glitch free power up/down high impedance for live insertion
- BiCMOS technology for high drive and low power dissipation
- -40°C to 85°C commercial temperature and V_{CC} specifications
- Modified specifications across V_{CC} and temperature ($V_{CC} = 5.0V \pm 1\%$, $T = 25^{\circ}\text{C} \pm 20^{\circ}\text{C}$) present more realistic system conditions
- Available in TSSOP (MTC)

Ordering Code:

Order Number	Package Number	Package Description
V320MTC	MTC24	24-Lead Thin Shrink Small Outline Package, JEDEC MO-153, 4.4mm Wide

Device also available in Tape and Reel. Specify by appending suffix letter "X" to the ordering code.

Connection Diagram

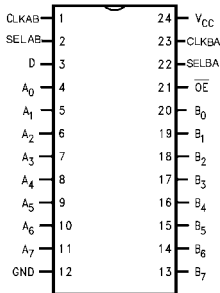

Pin Descriptions

Pin Names	Description
D	Direction A-to-B (High) B-to A (Low)
\overline{OE}	Output Enable (Active LOW)
CLKAB/SELAB	A-to-B Clock/Select
CLKBA/SELBA	B-to-A Clock/Select
A0-7	A Inputs/Outputs (TTL)
B0-7	B Inputs/Outputs (TTL)

Functional Table

\overline{OE}	D	SELBA	SELBA	CLKAB	CLKBA	A ₀ -A ₇	B ₀ -B ₇	Function
H	X	X	X	H or L	H or L			Isolation
H	X	X	X	LH	X	Input	Input	CLK A Data into A
H	X	X	X	X	LH			CLK B Data into A Reg.
L	H	L	X	X	X			A to B – Transparent
L	H	L	X	LH	X			CLK A Data into A Reg.
L	H	H	X	H or L	X	Input	Output	A Reg. to B (Storage)
L	H	H	X	LH	X			CLK A Data into A Reg. and B output
L	L	X	L	X	X			B to A – Transparent
L	L	X	L	X	LH			CLK B Data into B Reg.
L	L	X	H	X	H or L	Output	Input	B Reg. to A (Storage)
L	L	X	H	X	LH			CLK B Data into B Reg. and A output

L = Low
 H = High
 LH = Low to High transition
 X = Don't Care

Logic Diagram

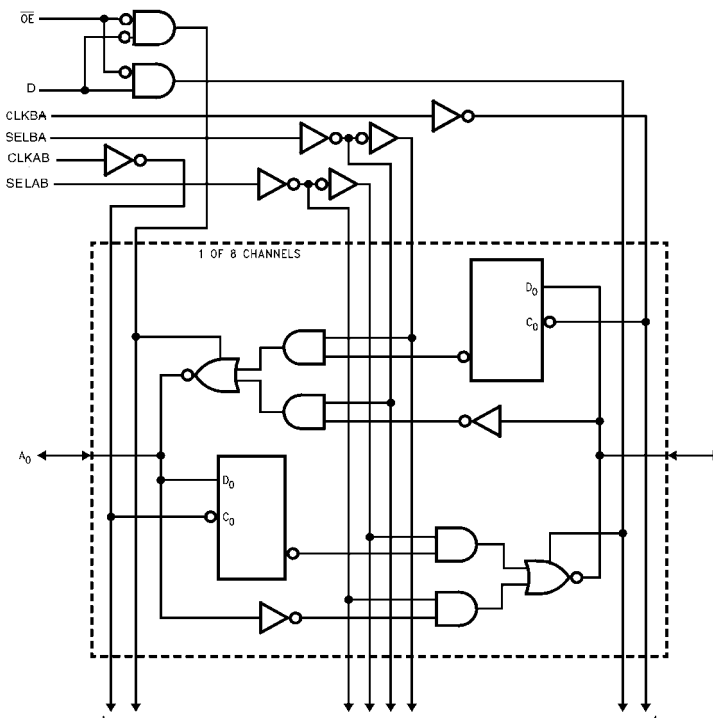

Please note that this diagram is provided only for the understanding of logic operations and should not be used to estimate propagation delays.

Absolute Maximum Ratings(Note 1)

DC Input Voltage (V_I)	-0.5V to +7.0V
DC Output Voltage (V_O)	
Outputs 3-STATE	-0.5V to +7.0V
Outputs Active (Note 2)	-0.5V to $V_{CC} + 0.5V$
DC Output Sink Current into A-port/B-port I_{OL}	64 mA
DC Output Source Current from A-port/B-port I_{OH}	-32 mA
DC Input Diode Current (I_{IK})	
$V_I < 0_V$	-30 mA to +5.0 mA
ESD Rating typical	> 2000V
Storage temperature (T_{STG})	-65° C to +15° C
Max I_{OL} (Current Applied to a LOW Output)	2 X I_{OL} Spec.

Recommended Operating Conditions

Supply Voltage V_{CC}	
Operating V_{CC}	4.5V to 5.5V
Minimum Input Edge Rate	
Data Input	50 mV/ns
Enable	20 mV/ns
Clock	100 mV/ns
Operating Temperature (T_A)	-40° C to +85° C

Note 1: Absolute maximum ratings are values beyond which the device may be damaged or have its useful life impaired. Functional operation under these conditions is not implied.

Note 2: Either voltage limit or current limit is sufficient to protect inputs.

DC Electrical Characteristics (4.5V < V_{CC} ≤ 5.5V)

Over Recommended Operating Free-Air Temperature Range (Unless Otherwise Noted)

Symbol	Parameter	V_{CC} (V)	Min	Typ	Max	Units	Conditions	
V_{IH}	B-Port/A-Port	HIGH Level Input Voltage	4.5-5.5	2.0			V	Recognized HIGH Signal
			4.95-5.05	1.8 (Note 3)				
V_{IL}	B-Port/A-Port	LOW Level Input Voltage	4.5-5.5			0.8	V	Recognized LOW Signal
			4.95-5.05			1.2 (Note 3)		
V_{OH}	B-Port/A-Port	HIGH Level Output Voltage	4.5	2.5			V	-3 mA
			4.5	2.0				-32 mA
I_{OH}	B-Port/A-Port	High Level Output Current Drive	4.5	-32			mA	$V_{OH} = 2.0V$
V_{OL}	B-Port/A-Port	LOW Level Output Voltage	4.5	0.55			V	64 mA
I_{OL}	B-Port/A-Port	Low Level Output Current Drive (Sink)	4.5	64			mA	$V_{OL} = 0.55V$
I_{OS}	B-Port/A-Port	Short Circuit Current	5.5	-100		-275	mA	$V_{OUT} = 0.0V$
I_{OFF}	A-Port and Control Pins	Power-OFF Leakage Current	0.0			100uA	uA	$V_{OUT} = 5.5V$, All Others GND
I_{CCH}	B-Port/A-Port	Quiescent Power Supply Current	5.5			250	uA	All Outputs HIGH
I_{CCI}	B-Port/A-Port	B-Port/A-Port	5.5			30	mA	All Outputs LOW
I_{CCZ}	B-Port/A-Port	3-STATE Power Supply Current	5.5			50	uA	All Outputs 3-STATE

Note 3: Extended Characteristics (4.95 > V_{CC} > 5.05, $T = 25^{\circ}C \pm 20^{\circ}C$)

Capacitance and Dynamic Switching Characteristics

Over Recommended Operating Free-Air Temperature Range (Unless Otherwise Noted)

Symbol	Parameter	Min	Typ $T_A = 25^\circ\text{C}$	Max	Units	Conditions
C_{IN}	Input Capacitance (Control Pin)		5		pF	$V_{CC} = 5.0\text{V}$ $V_I = V_{CC}$ or 0
$C_{I/O}$	Output Capacitance (A and B ports)		11		pF	$V_{CC} = 5.0\text{V}$ $V_I = V_{CC}$ or 0
Output Switching Noise (Ground Bounce)						
V_{OLP}	Quiet Output Dynamic Peak V_{OL}			0.8	V	$V_{CC} = 5.0\text{V}$, $T = 25^\circ\text{C}$ $C_L = 50\text{ pF}$
V_{OLV}	Quiet Output Dynamic Valley V_{OL}	-1.2			V	
V_{OHV}	Quiet Output Dynamic Valley V_{OH}	2.5			V	
Input Noise Immunity (Dynamic Threshold)						
V_{IHD}	High Level Threshold Movement	2.2			V	$V_{CC} = 5.0\text{V}$, $T = 25^\circ\text{C}$
V_{ILD}	Low Level Threshold Movement			0.5	V	$C_L = 50\text{ pF}$

AC Operating Requirements

Over recommended ranges of supply voltage and operating free-air temperature

Symbol		Min	Typ	Max	Units
f_{CLOCK}	Max Clock Frequency		200 (Note 4)		MHz
t_{WIDTH}	Pulse Duration	HIGH or LOW	3.0		ns
t_{SU}	Setup Time	Bus to CLKAB/CLKBA	1.5		ns
t_{HOLD}	Hold Time	Bus to CLKAB/CLKBA	1.0		ns

Note 4: $C_L = 50\text{ pF}$

AC Electrical Characteristics

(-40°C to 85°C, V_{CC} = 4.5V to 5.5V) 1 Output Switching

Symbol	From (Input)	Mode	To (Output)	Min	Typ	Max	Units
Output Load: C_L = 50 pF, R_L = 500Ω, 1 Output Switching							
t _{PLH} , t _{PHL}	CLKAB/CLKBA	Register	Bus A or B	1.7		5.6	ns
t _{PLH} , t _{PHL}	Bus A or B	Transparent	Bus A or B	1.5		4.8	ns
t _{PLH} , t _{PHL}	SELAB/SELBA	Select Bus	Bus A or B	1.5		5.9	ns
t _{PLZ} , t _{PHZ}	\overline{OE}	Output Disable	Bus A or B	1.5		6.0	ns
t _{PZH} , t _{PZL}	\overline{OE}	Output Enable	Bus A or B	1.5		6.3	ns
t _{PLZ} , t _{PHZ}	Direction (D)	Dir. Disable	Bus A or B	1.5		6.0	ns
t _{PZH} , t _{PZL}	Direction (D)	Dir. Enable	Bus A or B	1.5		6.3	ns
t _{RISE}	Transition Time, Outputs (1V to 2V)			0.3		1.2	ns
t _{FALL}	Transition Time, Outputs (1V to 2V)			0.3		1.4	ns
Output Load: C_L = 250 pF, R_L = 500Ω, 1 Output Switching							
t _{PLH} , t _{PHL}	CLKAB/CLKBA	Register	Bus A or B	2.0		7.5	ns
t _{PLH} , t _{PHL}	Bus A or B	Transparent	Bus A or B	2.0		7.0	ns
t _{PLH} , t _{PHL}	SELAB/SELBA	Select Bus	Bus A or B	2.0		7.5	ns
t _{PLZ} , t _{PHZ}	\overline{OE}	Output Disable	Bus A or B	(Note 5)		(Note 5)	ns
t _{PZH} , t _{PZL}	\overline{OE}	Output Enable	Bus A or B	2.0		8.0	ns
t _{PLZ} , t _{PHZ}	Direction (D)	Dir. Disable	Bus A or B	(Note 5)		(Note 5)	ns
t _{PZH} , t _{PZL}	Direction (D)	Dir. Enable	Bus A or B	2.0		8.3	ns
t _{RISE}	Transition Time, Outputs (1V to 2V)			1.7		3.9	ns
t _{FALL}	Transition Time, Outputs (1V to 2V)			0.8		3.1	ns
Output Load: C_L = 500 pF, R_L = 500Ω, Output Switching							
t _{PLH} , t _{PHL}	CLKAB/CLKBA	Register	Bus A or B	3.0		12.2	ns
t _{PLH} , t _{PHL}	Bus A or B	Transparent	Bus A or B	3.0		11.6	ns
t _{PLH} , t _{PHL}	SELAB/SELBA	Select Bus	Bus A or B	3.0		12.4	ns
t _{PLZ} , t _{PHZ}	\overline{OE}	Output Disable	Bus A or B	(Note 5)		(Note 5)	ns
t _{PZH} , t _{PZL}	\overline{OE}	Output Enable	Bus A or B	3.0		12.6	ns
t _{PLZ} , t _{PHZ}	Direction (D)	Dir. Disable	Bus A or B	(Note 5)		(Note 5)	ns
t _{PZH} , t _{PZL}	Direction (D)	Dir. Enable	Bus A or B	6.3		13.2	ns
t _{RISE}	Transition Time, Outputs (1V to 2V)			3.5		7.2	ns
t _{FALL}	Transition Time, Outputs (1V to 2V)			1.4		5.1	ns

Note 5: 3-STATE delays are dominated by the RC Network (500 Ω/ 250 pF, or 500 Ω/ 500 pF) on the output and thus have been excluded from this datasheet.

AC Electrical Characteristics (-40°C to 85°C, V_{CC} = 4.5V to 5.5V) 8 Output Switching

Symbol	From (Input)	Mode	To (Output)	Min	Typ	Max	Units
Output Load: C_L = 50 pF, R_L = 500Ω, 8 Outputs Switching							
t _{PLH} , t _{PHL}	CLKAB/CLKBA	Register	Bus A or B	1.5		6.6	ns
t _{PLH} , t _{PHL}	Bus A or B	Transparent	Bus A or B	1.5		6.3	ns
t _{PLH} , t _{PHL}	SELAB/SELBA	Select Bus	Bus A or B	1.5		6.6	ns
t _{PLZ} , t _{PHZ}	OE	Output Disable	Bus A or B	1.5		6.6	ns
t _{PZH} , t _{PZL}	OE	Output Enable	Bus A or B	1.5		6.6	ns
t _{PLZ} , t _{PHZ}	Direction (D)	Dir. Disable	Bus A or B	1.5		6.6	ns
t _{PZH} , t _{PZL}	Direction (D)	Dir. Enable	Bus A or B	1.5		7.6	ns
t _{OSSL}	Output to Output Skew (Note 6)					1.3	ns
t _{OSSL}	Output to Output Skew (Note 6)					1.1	ns
t _{RISE}	Transition Time, Outputs (1V to 2V)			0.5		1.5	ns
t _{FALL}	Transition Time, Outputs (1V to 2V)			0.4		1.9	ns
Output Load: C_L = 250 pF, R_L = 500Ω, 8 Outputs Switching							
t _{PLH} , t _{PHL}	CLKAB/CLKBA	Register	Bus A or B	2.5		11.2	ns
t _{PLH} , t _{PHL}	Bus A or B	Transparent	Bus A or B	2.5		9.5	ns
t _{PLH} , t _{PHL}	SELAB/SELBA	Select Bus	Bus A or B	2.5		11.2	ns
t _{PLZ} , t _{PHZ}	OE	Output Disable	Bus A or B	(Note 8)		(Note 8)	ns
t _{PZH} , t _{PZL}	OE	Output Enable	Bus A or B	2.5		11.5	ns
t _{PLZ} , t _{PHZ}	Direction (D)	Dir. Disable	Bus A or B	(Note 8)		(Note 8)	ns
t _{PZH} , t _{PZL}	Direction (D)	Dir. Enable	Bus A or B	2.5		13.5	ns
t _{OSSL}	Output to Output Skew (Note 8)					2.5	ns
t _{OSSL}	Output to Output Skew (Note 8)					2.0	ns
t _{RISE}	Transition Time, Outputs (1V to 2V)			2.0		5.5	ns
t _{FALL}	Transition Time, Outputs (1V to 2V)			1.4		4.4	ns
Output Load: C_L = 500 pF, R_L = 500Ω, 8 Outputs Switching							
t _{PLH} , t _{PHL}	CLKAB/CLKBA	Register	Bus A or B	3.5		17.0	ns
t _{PLH} , t _{PHL}	Bus A or B	Transparent	Bus A or B	3.5		15.9	ns
t _{PLH} , t _{PHL}	SELAB/SELBA	Select Bus	Bus A or B	3.5		17.0	ns
t _{PLZ} , t _{PHZ}	OE	Output Disable	Bus A or B	(Note 8)		(Note 8)	ns
t _{PZH} , t _{PZL}	OE	Output Enable	Bus A or B	3.5		18.5	ns
t _{PLZ} , t _{PHZ}	Direction (D)	Dir. Disable	Bus A or B	(Note 8)		(Note 8)	ns
t _{PZH} , t _{PZL}	Direction (D)	Dir. Enable	Bus A or B	3.5		22.3	ns
t _{OSSL}	Output to Output Skew (Note 6)					3.9	ns
t _{OSSL}	Output to Output Skew (Note 6)					3.1	ns
t _{RISE}	Transition Time, Outputs (1V to 2V)			4.4		7.8	ns
t _{FALL}	Transition Time, Outputs (1V to 2V)			2.5		6.6	ns

Note 6: Skew is defined as the absolute value of the difference between the actual propagation delays for any two outputs of the same device. The specification applies to outputs switching in the same direction also.

Note 7: Device to Device Skew is defined as the absolute value of the difference between the actual propagation delays for any two outputs from any two devices.

Note 8: 3-STATE delays are dominated by the RC Network (500 Ω/ 250 pF, or 500 Ω/ 500 pF) on the output and thus have been excluded from this datasheet.

Extended AC Electrical Characteristics (5°C to 45°C, $V_{CC} = 4.95V$ to $5.05V$), 1 Output Switching

Symbol	From (Input)	Mode	To (Output)	Min	Typ	Max	Units
Output Load: $C_L = 50$ pF, $R_L = 500\Omega$, 1 Output Switching							
t_{PLH}, t_{PHL}	CLKAB/CLKBA	Register	Bus A or B	1.5		5.2	ns
t_{PLH}, t_{PHL}	Bus A or B	Transparent	Bus A or B	1.5		4.3	ns
t_{PLH}, t_{PHL}	SELAB/SELBA	Select Bus	Bus A or B	2.0		4.8	ns
t_{PLZ}, t_{PHZ}	\overline{OE}	Output Disable	Bus A or B	1.5		6.0	ns
t_{PZH}, t_{PZL}	\overline{OE}	Output Enable	Bus A or B	2.2		5.0	ns
t_{PLZ}, t_{PHZ}	Direction (D)	Dir. Disable	Bus A or B	1.5		6.0	ns
t_{PZH}, t_{PZL}	Direction (D)	Dir. Enable	Bus A or B	2.2		5.2	ns
t_{PV}	Device to Device Skew (Note 10)					2.0	ns
t_{RISE}	Transition Time, Outputs (1V to 2V)			3.0		1.2	ns
t_{FALL}	Transition Time, Outputs (1V to 2V)			0.4		1.2	ns
Output Load: $C_L = 250$ pF, $R_L = 500\Omega$, 1 Output Switching							
t_{PLH}, t_{PHL}	CLKAB/CLKBA	Register	Bus A or B	2.5		7.4	ns
t_{PLH}, t_{PHL}	Bus A or B	Transparent	Bus A or B	2.5		6.7	ns
t_{PLH}, t_{PHL}	SELAB/SELBA	Select Bus	Bus A or B	3.0		7.2	ns
t_{PLZ}, t_{PHZ}	\overline{OE}	Output Disable	Bus A or B	(Note 9)		(Note 9)	ns
t_{PZH}, t_{PZL}	\overline{OE}	Output Enable	Bus A or B	3.2		7.2	ns
t_{PLZ}, t_{PHZ}	Direction (D)	Dir. Disable	Bus A or B	(Note 9)		(Note 9)	ns
t_{PZH}, t_{PZL}	Direction (D)	Dir. Enable	Bus A or B	3.2		8.1	ns
t_{PV}	Device to Device Skew (Note 10)					2.5	ns
t_{RISE}	Transition Time, Outputs (1V to 2V)			2.1		3.5	ns
t_{FALL}	Transition Time, Outputs (1V to 2V)			1.0		2.5	ns
Output Load: $C_L = 500$ pF, $R_L = 500\Omega$, 1 Output Switching							
t_{PLH}, t_{PHL}	CLKAB/CLKBA	Register	Bus A or B	3.5		10.6	ns
t_{PLH}, t_{PHL}	Bus A or B	Transparent	Bus A or B	3.5		10.0	ns
t_{PLH}, t_{PHL}	SELAB/SELBA	Select Bus	Bus A or B	4.0		10.6	ns
t_{PLZ}, t_{PHZ}	\overline{OE}	Output Disable	Bus A or B	(Note 9)		(Note 9)	ns
t_{PZH}, t_{PZL}	\overline{OE}	Output Enable	Bus A or B	4.2		10.5	ns
t_{PLZ}, t_{PHZ}	Direction (D)	Dir. Disable	Bus A or B	(Note 9)		(Note 9)	ns
t_{PZH}, t_{PZL}	Direction (D)	Dir. Enable	Bus A or B	4.2		11.3	ns
t_{PV}	Device to Device Skew					5.0	ns
t_{RISE}	Transition Time, Outputs (1V to 2V)			3.8		6.4	ns
t_{FALL}	Transition Time, Outputs (1V to 2V)			1.7		3.8	ns

Note 9: 3-STATE delays are dominated by the RC Network (500 Ω / 250 pF, or 500 Ω / 500 pF) on the output and thus have been excluded from this datasheet.

Note 10: Device to Device Skew is defined as the absolute value of the difference between the actual propagation delays for any two outputs from any two devices.

Extended AC Electrical Characteristics (5°C to 45°C, V_{CC} = 4.95V to 5.05V), 8 Outputs Switching

Symbol	From (Input)	Mode	To (Output)	Min	Typ	Max	Units
Output Load: C_L = 50 pF, R_L = 500Ω, 8 Outputs Switching							
t _{PLH} , t _{PHL}	CLKAB/CLKBA	Register	Bus A or B	2.5		6.2	ns
t _{PLH} , t _{PHL}	Bus A or B	Transparent	Bus A or B	2.5		5.4	ns
t _{PLH} , t _{PHL}	SELAB/SELBA	Select Bus	Bus A or B	2.5		5.7	ns
t _{PLZ} , t _{PHZ}	\overline{OE}	Output Disable	Bus A or B	1.5		6.0	ns
t _{PZH} , t _{PZL}	\overline{OE}	Output Enable	Bus A or B	2.5		5.7	ns
t _{PLZ} , t _{PHZ}	Direction (D)	Dir. Disable	Bus A or B	1.5		6.0	ns
t _{PZH} , t _{PZL}	Direction (D)	Dir. Enable	Bus A or B	2.5		7.2	ns
t _{OSSL}	Output to Output Skew (Note 12)					1.1	ns
t _{OSLH}	Output to Output Skew (Note 12)					0.9	ns
t _{PV}	Device to Device Skew (Note 13)					2.5	ns
t _{RISE}	Transition Time, Outputs (1V to 2V)			0.5		1.3	ns
t _{FALL}	Transition Time, Outputs (1V to 2V)			0.6		1.4	ns
Output Load: C_L = 250 pF, R_L = 500Ω, 8 Outputs Switching							
t _{PLH} , t _{PHL}	CLKAB/CLKBA	Register	Bus A or B	3.5		10.5	ns
t _{PLH} , t _{PHL}	Bus A or B	Transparent	Bus A or B	3.5		10.5	ns
t _{PLH} , t _{PHL}	SELAB/SELBA	Select Bus	Bus A or B	3.5		10.5	ns
t _{PLZ} , t _{PHZ}	\overline{OE}	Output Disable	Bus A or B	(Note 11)		(Note 11)	ns
t _{PZH} , t _{PZL}	\overline{OE}	Output Enable	Bus A or B	3.5		10.5	ns
t _{PLZ} , t _{PHZ}	Direction (D)	Dir. Disable	Bus A or B	(Note 11)		(Note 11)	ns
t _{PZH} , t _{PZL}	Direction (D)	Dir. Enable	Bus A or B	3.5		14.8	ns
t _{OSSL}	Output to Output Skew (Note 12)					2.3	ns
t _{OSLH}	Output to Output Skew (Note 12)					1.9	ns
t _{PV}	Device to Device Skew (Note 13)					4.0	ns
t _{RISE}	Transition Time, Outputs (1V to 2V)			2.7		4.7	ns
t _{FALL}	Transition Time, Outputs (1V to 2V)			1.8		3.7	ns
Output Load: C_L = 500 pF, R_L = 500Ω, 8 Outputs Switching							
t _{PLH} , t _{PHL}	CLKAB/CLKBA	Register	Bus A or B	5.0		15.3	ns
t _{PLH} , t _{PHL}	Bus A or B	Transparent	Bus A or B	5.0		13.6	ns
t _{PLH} , t _{PHL}	SELAB/SELBA	Select Bus	Bus A or B	5.0		15.3	ns
t _{PLZ} , t _{PHZ}	\overline{OE}	Output Disable	Bus A or B	(Note 11)		(Note 11)	ns
t _{PZH} , t _{PZL}	\overline{OE}	Output Enable	Bus A or B	5.0		15.1	ns
t _{PLZ} , t _{PHZ}	Direction (D)	Dir. Disable	Bus A or B	(Note 11)		(Note 11)	ns
t _{PZH} , t _{PZL}	Direction (D)	Dir. Enable	Bus A or B	5.0		19.4	ns
t _{OSSL}	Output to Output Skew (Note 12)					3.5	ns
t _{OSLH}	Output to Output Skew (Note 12)					2.9	ns
t _{PV}	Device to Device Skew					5.0	ns
t _{RISE}	Transition Time, Outputs (1V to 2V)			4.6		7.0	ns
t _{FALL}	Transition Time, Outputs (1V to 2V)			2.9		4.9	ns

Note 11: 3-STATE delays are dominated by the RC Network (500 Ω/ 250 pF, or 500 Ω/ 500 pF) on the output and thus have been excluded from this datasheet.

Note 12: Skew is defined as the absolute value of the difference between the actual propagation delays for any two outputs of the same device. The specification applies to outputs switching in the same direction also.

Note 13: Device to Device Skew is defined as the absolute value of the difference between the actual propagation delays for any two outputs from any two devices.

AC Loading and Waveforms

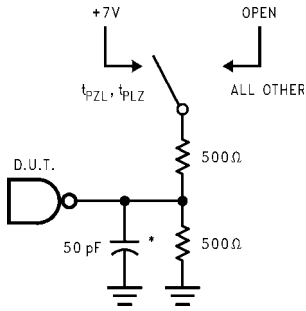

*Includes jig and probe capacitance

FIGURE 1. Standard AC Test Load

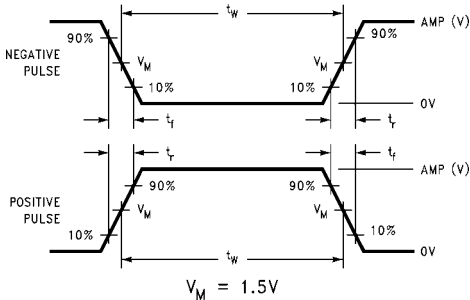

**FIGURE 2. Test Input Signal Levels
Input Pulse Requirements**

Test Input Signal Requirements

Amplitude	Rep. Rate	t_w	t_r	t_f
3.0V	1 MHz	500 ns	2.5 ns	2.5 ns

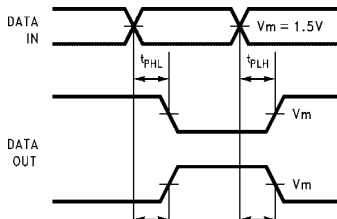
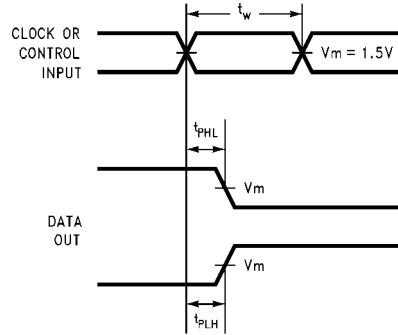
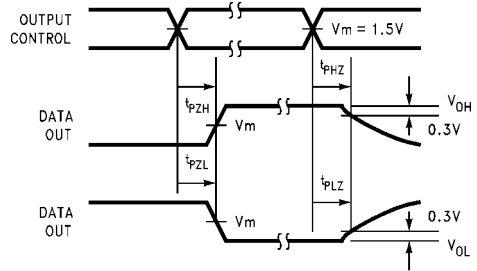

FIGURE 3. Propagation Delay Waveforms for Inverting and Non-Inverting Functions



**FIGURE 4. Propagation Delay,
Pulse Width Waveforms**



**FIGURE 5. 3-STATE Output HIGH
and LOW Enable and Disable Times**

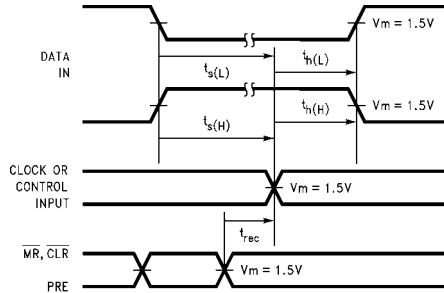

**FIGURE 6. Setup Time, Hold Time
and Recovery Time Waveforms**

