

阅读申明

- 1.本站收集的数据手册和产品资料都来自互联网，版权归原作者所有。如读者和版权方有任何异议请及时告之，我们将妥善解决。
- 2.本站提供的中文数据手册是英文数据手册的中文翻译，其目的是协助用户阅读，该译文无法自动跟随原稿更新，同时也可能存在翻译上的不当。建议读者以英文原稿为参考以便获得更精准的信息。
- 3.本站提供的产品资料，来自厂商的技术支持或者使用者的心得体会等，其内容可能存在描述上的差异，建议读者做出适当判断。
- 4.如需与我们联系，请发邮件到marketing@iczoom.com，主题请标有“数据手册”字样。

Read Statement

1. The datasheets and other product information on the site are all from network reference or other public materials, and the copyright belongs to the original author and original published source. If readers and copyright owners have any objections, please contact us and we will deal with it in a timely manner.
2. The Chinese datasheets provided on the website is a Chinese translation of the English datasheets. Its purpose is for reader's learning exchange only and do not involve commercial purposes. The translation cannot be automatically updated with the original manuscript, and there may also be improper translations. Readers are advised to use the English manuscript as a reference for more accurate information.
3. All product information provided on the website refer to solutions from manufacturers' technical support or users the contents may have differences in description, and readers are advised to take the original article as the standard.
4. If you have any questions, please contact us at marketing@iczoom.com and mark the subject with "Datasheets" .

PTN3341

High speed differential line driver

Rev. 01 — 6 August 2002

Product data

1. Description

The PTN3341 is a differential line driver that implements the electrical characteristics of Low-Voltage Differential Signaling (LVDS) that meets or exceeds the requirements of the ANSI TIA/EIA-644 Standard. LVDS is used to achieve higher data rates on commonly used media. LVDS overcomes the limitations of achievable slew rates and EMI restrictions of previous differential signaling techniques. The PTN3341 operates at 3.3 volt supply levels and current mode output drivers. The output drivers will deliver a minimum of 250 mV into a 50 Ω load when enabled.

The intended application of this device is for point to point baseband transmission rates over a controlled impedance media of approximately 100 Ω . The maximum rates and distance of data transfer are dependent upon the attenuation characteristics of the media selected and the noise coupling to the environment.

The PTN3341 is designed to function over the full industrial temperature range of $-40\text{ }^{\circ}\text{C}$ to $+85\text{ }^{\circ}\text{C}$.

2. Features

- Meets or exceeds the requirements of ANSI TIA/EIA-644 Standard
- Low-Voltage Differential Signaling with output voltage of 350 mV across a 50 Ω load or 700 mV across a 100 Ω load
- 200 ps maximum channel-to-channel output skew
- 600 ps typical output voltage rise and fall times
- Driver at high impedance when disabled or with $V_{CC} = 0\text{ V}$
- 5 volt tolerant inputs with Low Voltage TTL (LVTTTL) logic input levels
- Pin-compatible with AM26LS31, SN65LVDS31, SN65LVDM31 and PTN3331.

3. Applications

- Low voltage, low EMI, high speed differential signaling
- Point-to-point high speed data transmission
- High performance switches and routers.



PHILIPS

4. Ordering information

Table 1: Ordering information

| Type number | Package | | Version |
|-------------|---------|--|----------|
| | Name | Description | |
| PTN3341DH | TSSOP16 | plastic thin shrink small outline package; 16 leads; body width 4.4 mm | SOT403-1 |
| PTN3341D | SO16 | plastic small outline package; 16 leads; body width 3.9 mm | SOT109-1 |

5. Functional diagram

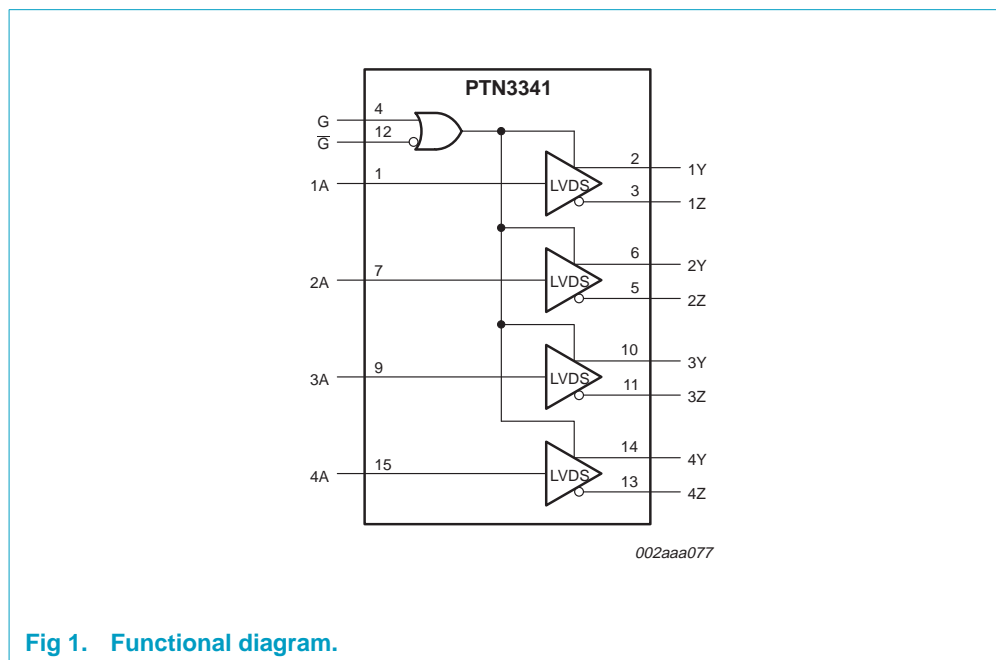
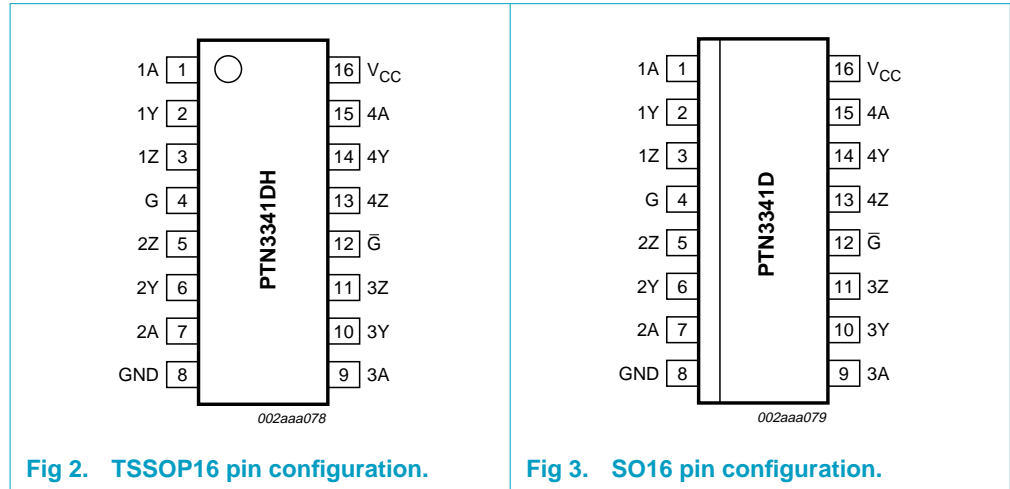

Fig 1. Functional diagram.

6. Pinning information

6.1 Pinning



6.2 Pin description

Table 2: Pin description

| Symbol | Pin | Description |
|-----------------|-----|---------------------------|
| 1A | 1 | LVTTTL input |
| 1Y | 2 | LVDS non-inverting output |
| 1Z | 3 | LVDS inverting output |
| G | 4 | Enable (active-HIGH) |
| 2Z | 5 | LVDS inverting output |
| 2Y | 6 | LVDS non-inverting output |
| 2A | 7 | LVTTTL input |
| GND | 8 | Ground |
| 3A | 9 | LVTTTL input |
| 3Y | 10 | LVDS non-inverting output |
| 3Z | 11 | LVDS inverting output |
| \bar{G} | 12 | Enable (active-LOW) |
| 4Z | 13 | LVDS inverting output |
| 4Y | 14 | LVDS non-inverting output |
| 4A | 15 | LVTTTL input |
| V _{CC} | 16 | Supply |

7. Functional description

7.1 Function table

Table 3: Function table

H = HIGH level; L = LOW level; X = irrelevant; Z = high impedance.

| Input A | Enables | | Outputs | |
|-------------------|----------|-------------------------|----------|----------|
| | G | $\overline{\mathbf{G}}$ | Y | Z |
| H | H | X | H | L |
| L | H | X | L | H |
| H | X | L | H | L |
| L | X | L | L | H |
| X | L | H | Z | Z |
| Open | H | X | L | H |
| Open | X | L | L | H |

8. Limiting values

Table 4: Limiting values

In accordance with the Absolute Maximum Rating System (IEC 60134).

| Symbol | Parameter | Min | Max | Unit |
|-----------|-------------------------------------|------------|------|------|
| V_{CC} | supply voltage | -0.5 | 4.0 | V |
| V_I | input voltage | -0.5 | 6 | V |
| | short circuit duration | Continuous | | sec |
| T_{amb} | operating ambient temperature range | -40 | +85 | °C |
| T_j | operating junction temperature | -40 | +150 | °C |
| T_{stg} | storage temperature range | -65 | +150 | °C |
| | ESD | >2 | - | kV |

[1] Values beyond absolute maximum ratings can cause the device to be prematurely damaged. Absolute maximum ratings are stress ratings only and functional device operation is not implied.

9. Recommended operating conditions

Table 5: Recommended operating conditions

| Symbol | Parameter | Min | Nom | Max | Unit |
|----------|--------------------------|-----|-----|-----|------|
| V_{CC} | supply voltage | 3 | 3.3 | 3.6 | V |
| V_{IH} | HIGH-level input voltage | 2 | - | - | V |
| V_{IL} | LOW-level input voltage | - | - | 0.8 | V |

10. Static characteristics

Table 6: DC electrical characteristics

Over recommended operating conditions, unless otherwise noted.

| Symbol | Parameter | Conditions | Min | Typ ^[1] | Max | Unit |
|----------------------|--|---|-----|--------------------|-----|------|
| V _{OD} | differential output voltage | R _L = 100 Ω See Figure 4. | 480 | 700 | 860 | mV |
| | | R _L = 50 Ω See Figure 4. | 250 | 350 | 430 | mV |
| ΔV _{OD} | change in differential voltage magnitude between logic states | See Figure 4. | -25 | 0 | +25 | mV |
| V _{OC(SS)} | Steady-state common-mode output voltage | | 1.0 | 1.2 | 1.5 | V |
| ΔV _{OC(SS)} | Change in steady-state common-mode output voltage between logic states | | -30 | - | +30 | mV |
| V _{OC(PP)} | Peak-to-peak common-mode output voltage | | - | 70 | 100 | mV |
| I _{CC} | Supply current | V _I = 0.8 or 2 V; enabled, no load | - | 14 | 20 | mA |
| | | V _I = 0.8 or 2 V; enabled, R _L = 100 Ω | - | 35 | 40 | mA |
| | | V _I = 0.8 or 2 V; enabled, R _L = 50 Ω | - | 34 | 45 | mA |
| | | V _I = 0 V or V _{CC} ; disabled | - | 0.5 | 0.7 | mA |
| I _{IH} | HIGH-level input current | V _{IH} = 3 V | - | 3 | 10 | μA |
| I _{IL} | LOW-level input current | V _{IL} = 0 V | - | 0.1 | 10 | μA |
| I _{OS} | Output short circuit current | V _{O(Y)} or V _{O(Z)} = 0 V | - | 13 | 20 | mA |
| | | V _{OD} = 0 V | - | 13 | 20 | mA |
| I _{OZ} | High-impedance output current | V _{OD} = 0 V | -1 | - | +1 | μA |
| I _{O(OFF)} | Power-off output current | V _{CC} = 0 V; V _O = 2.4 V | -1 | - | +1 | μA |
| C _i | Input capacitance | | - | 3 | - | pF |

[1] All typical values are at T_{amb} = 25 °C and V_{CC} = 3.3 V.

11. Dynamic characteristics

Table 7: AC switching characteristics

Over recommended operating conditions, unless otherwise noted.

All parameters are with $R_L = 100 \Omega$, $C_L = 10 \text{ pF}$, unless otherwise noted.

| Symbol | Parameter | Conditions | Min | Typ ^[1] | Max | Unit |
|---------------|--|---|-----|--------------------|-----|------|
| t_{PLH} | Propagation delay, LOW-to-HIGH level output | $R_L = 100 \Omega$; $C_L = 10 \text{ pF}$ | 1.8 | 2.3 | 2.9 | ns |
| t_{PHL} | Propagation delay, HIGH-to-LOW level output | See Figure 5. | 1.8 | 2.3 | 2.9 | ns |
| t_r | Differential output rise time (20 to 80%) | [2] | 0.4 | 0.6 | 1.0 | ns |
| t_f | Differential output fall time (80 to 20%) | [2] | 0.4 | 0.6 | 1.0 | ns |
| $t_{sk(p)}$ | Pulse skew ($t_{PHL} - t_{PLH}$) | | - | 0.05 | - | ns |
| $t_{sk(o)}$ | Channel-to-channel output skew | [2], [3] | - | 0 | 0.2 | ns |
| $t_{sk(p-p)}$ | Part-to-part skew | [2], [4] | - | - | 1 | ns |
| t_{PZH} | Propagation delay, high-impedance to HIGH-level output | See Figure 6. | - | 6 | 15 | ns |
| t_{PZL} | Propagation delay, high-impedance to LOW-level output | | - | 6 | 15 | ns |
| t_{PHZ} | Propagation delay, HIGH-level to high-impedance output | | - | 6 | 15 | ns |
| t_{PLZ} | Propagation delay, LOW-level to high-impedance output | | - | 6 | 15 | ns |

[1] All typical values are at $T_{amb} = 25 \text{ }^\circ\text{C}$, and $V_{CC} = 3.3 \text{ V}$.

[2] Guaranteed by design and characterization.

[3] $t_{sk(o)}$ is the skew between specified outputs of a single device with all driving inputs connected together and the outputs switching in the same direction while driving identical specified loads.

[4] $t_{sk(p-p)}$ is the magnitude of the difference in propagation delay times between any specified terminals of two devices when both devices operate with the same supply voltages, same temperature, and have identical packages and test circuits.

12. Test figures

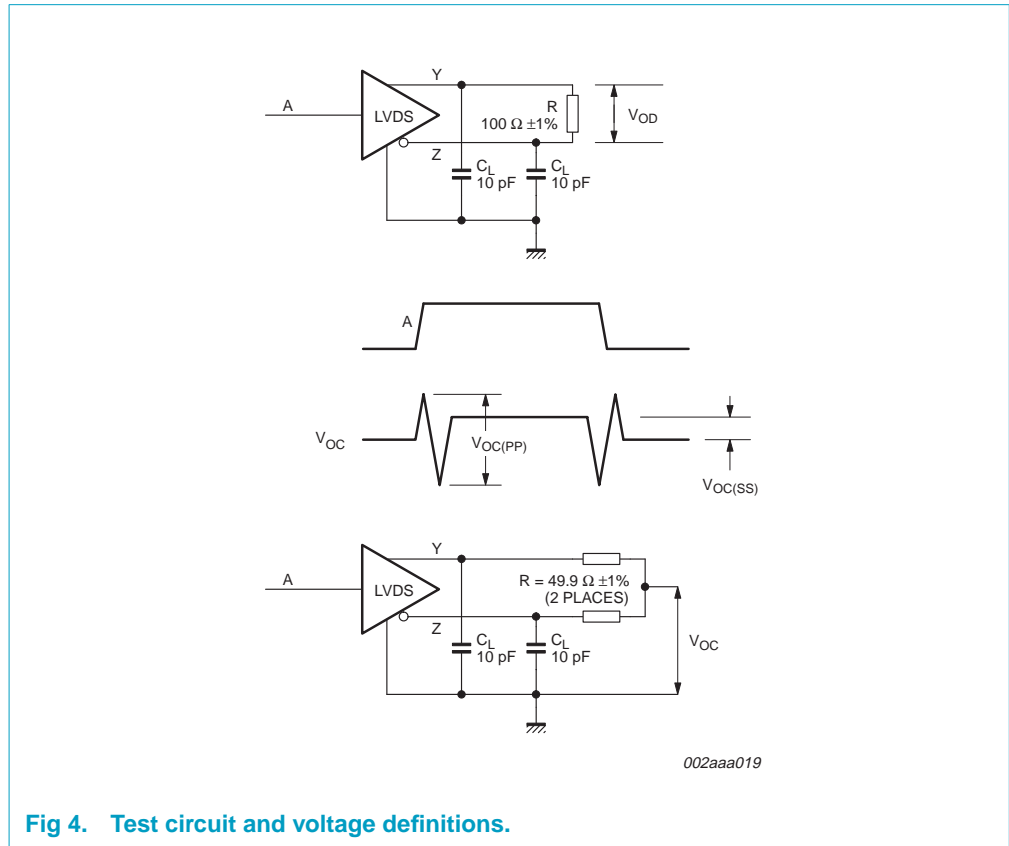

Fig 4. Test circuit and voltage definitions.

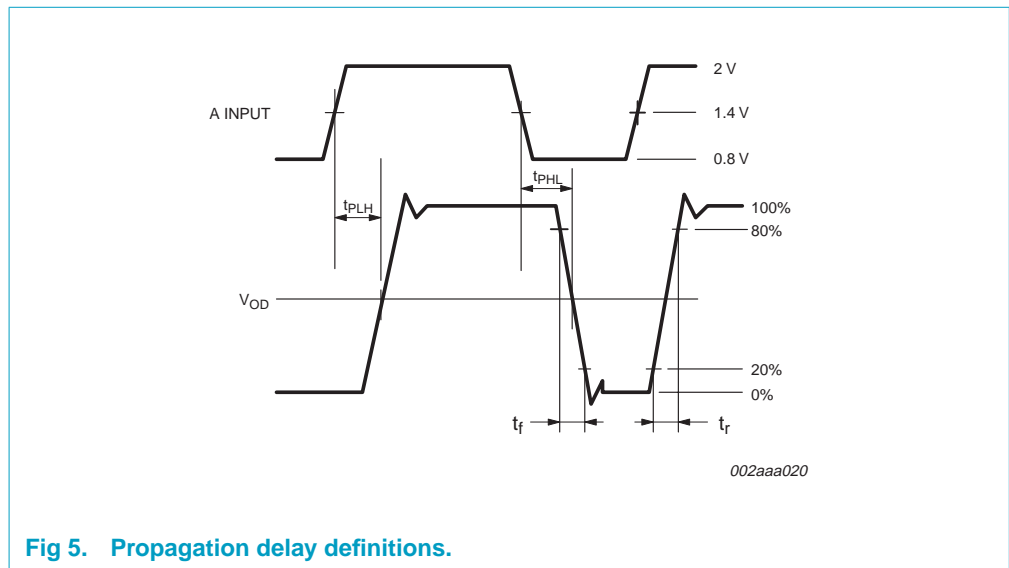

Fig 5. Propagation delay definitions.

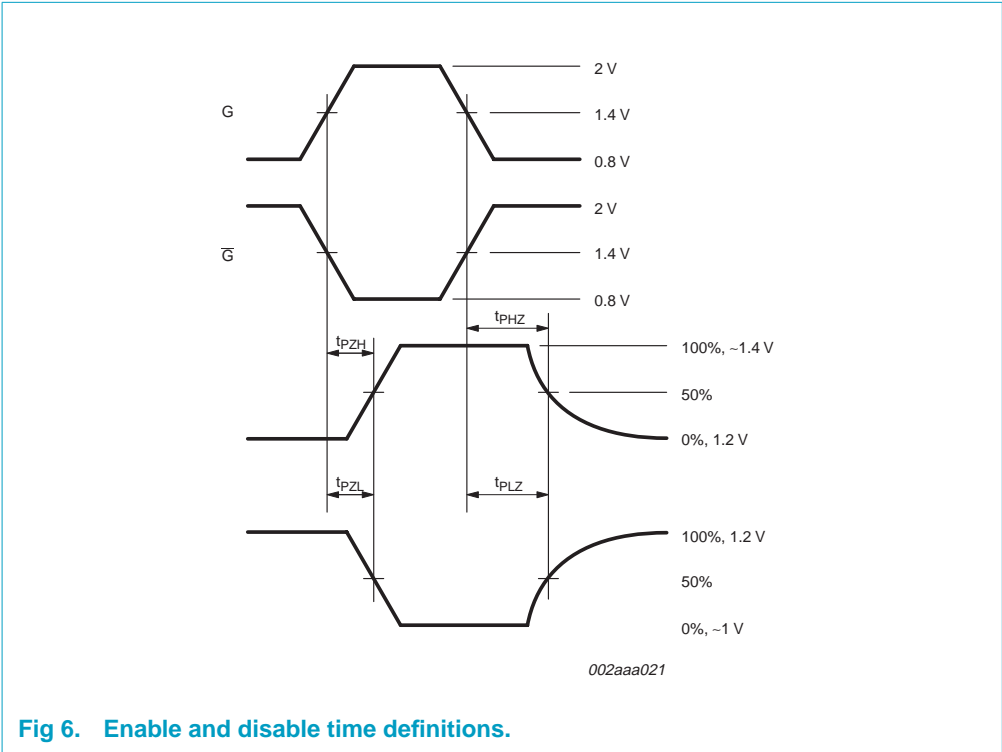

Fig 6. Enable and disable time definitions.

13. Package outline

TSSOP16: plastic thin shrink small outline package; 16 leads; body width 4.4 mm

SOT403-1

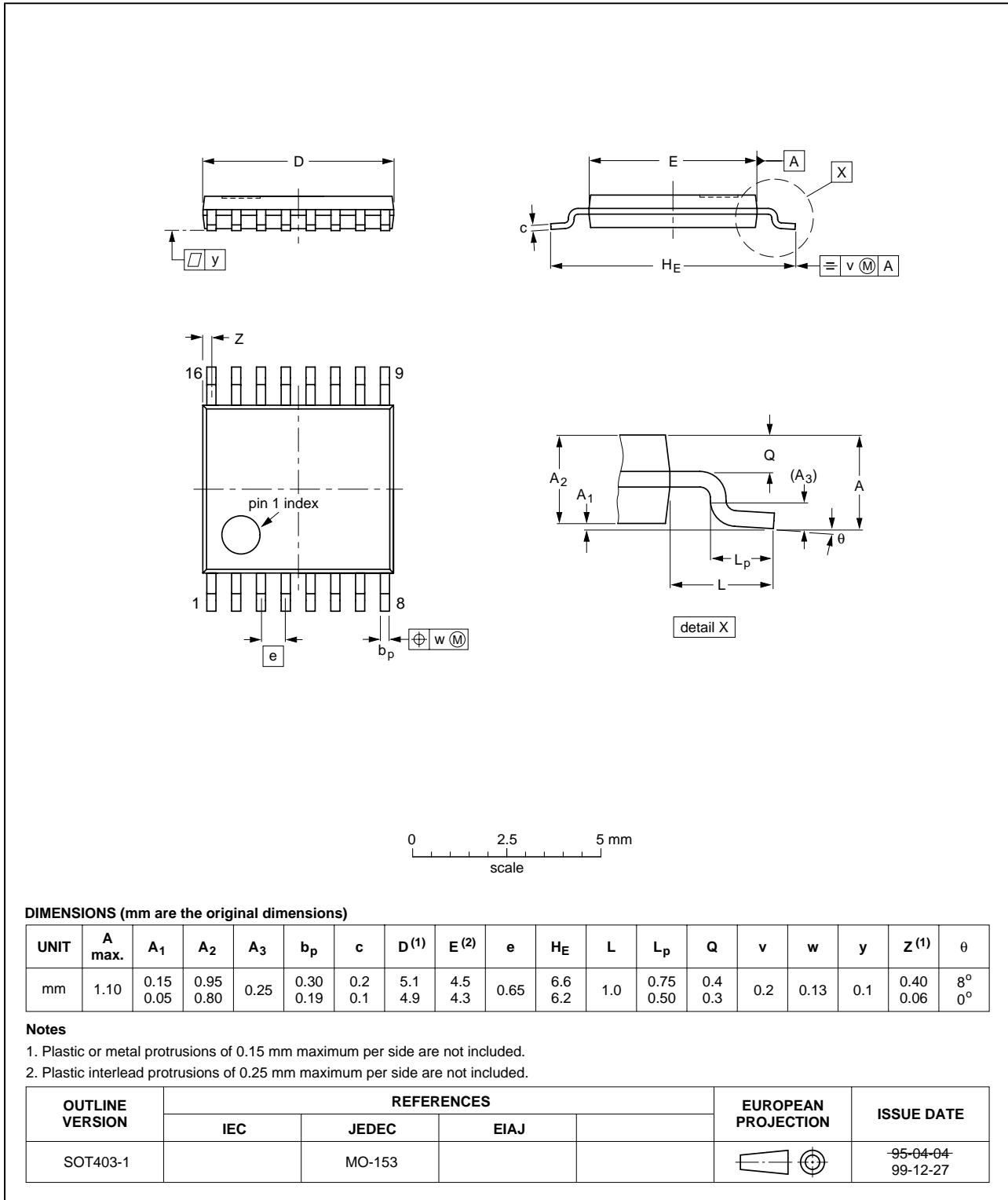

Fig 7. TSSOP16 package outline (SOT403-1).

SO16: plastic small outline package; 16 leads; body width 3.9 mm

SOT109-1

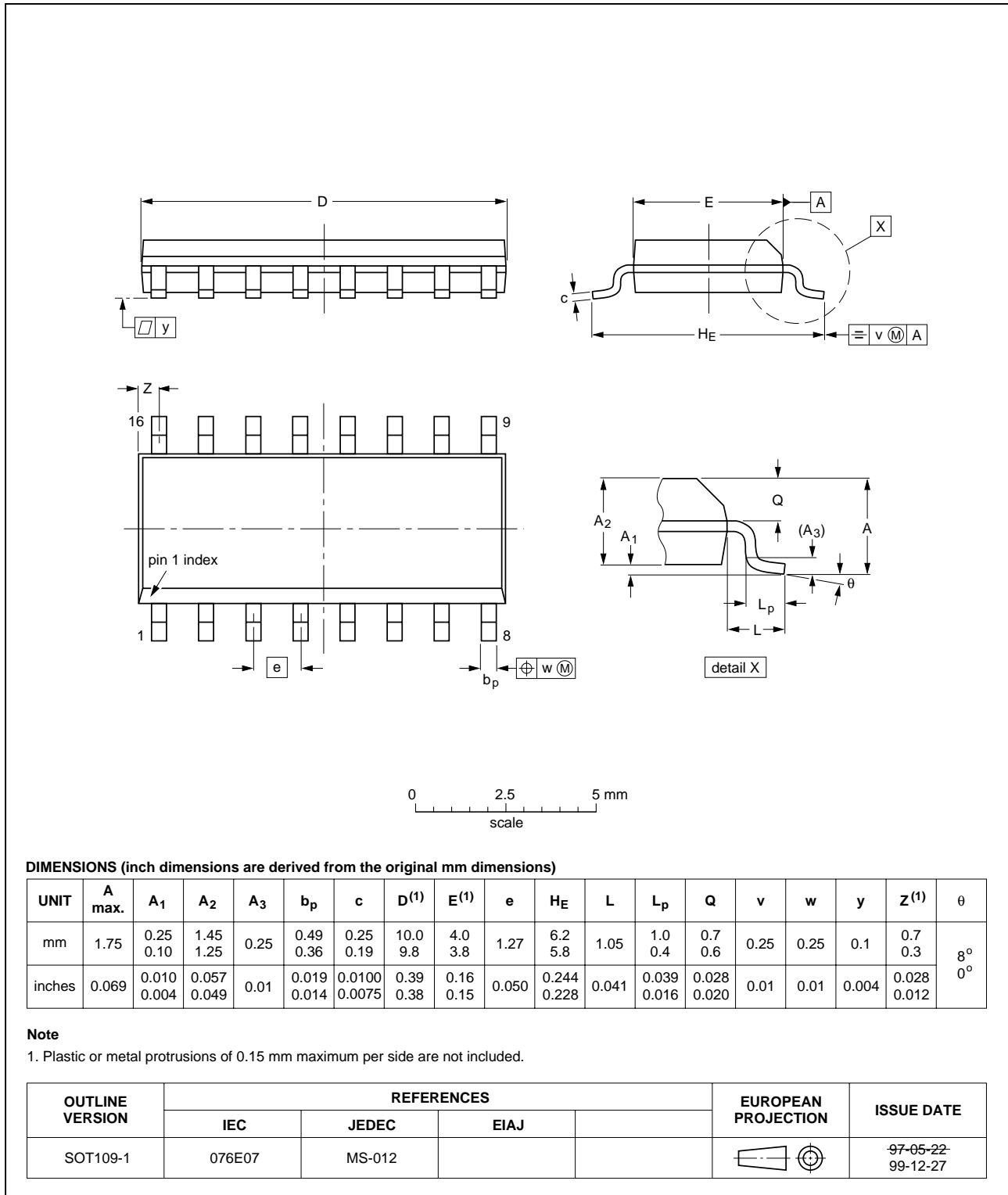

Fig 8. SO16 package outline (SOT109-1).

14. Soldering

14.1 Introduction to soldering surface mount packages

This text gives a very brief insight to a complex technology. A more in-depth account of soldering ICs can be found in our *Data Handbook IC26; Integrated Circuit Packages* (document order number 9398 652 90011).

There is no soldering method that is ideal for all surface mount IC packages. Wave soldering can still be used for certain surface mount ICs, but it is not suitable for fine pitch SMDs. In these situations reflow soldering is recommended.

14.2 Reflow soldering

Reflow soldering requires solder paste (a suspension of fine solder particles, flux and binding agent) to be applied to the printed-circuit board by screen printing, stencilling or pressure-syringe dispensing before package placement.

Several methods exist for reflowing; for example, convection or convection/infrared heating in a conveyor type oven. Throughput times (preheating, soldering and cooling) vary between 100 and 200 seconds depending on heating method.

Typical reflow peak temperatures range from 215 to 250 °C. The top-surface temperature of the packages should preferably be kept below 220 °C for thick/large packages, and below 235 °C small/thin packages.

14.3 Wave soldering

Conventional single wave soldering is not recommended for surface mount devices (SMDs) or printed-circuit boards with a high component density, as solder bridging and non-wetting can present major problems.

To overcome these problems the double-wave soldering method was specifically developed.

If wave soldering is used the following conditions must be observed for optimal results:

- Use a double-wave soldering method comprising a turbulent wave with high upward pressure followed by a smooth laminar wave.
- For packages with leads on two sides and a pitch (e):
 - larger than or equal to 1.27 mm, the footprint longitudinal axis is **preferred** to be parallel to the transport direction of the printed-circuit board;
 - smaller than 1.27 mm, the footprint longitudinal axis **must** be parallel to the transport direction of the printed-circuit board.

The footprint must incorporate solder thieves at the downstream end.

- For packages with leads on four sides, the footprint must be placed at a 45° angle to the transport direction of the printed-circuit board. The footprint must incorporate solder thieves downstream and at the side corners.

During placement and before soldering, the package must be fixed with a droplet of adhesive. The adhesive can be applied by screen printing, pin transfer or syringe dispensing. The package can be soldered after the adhesive is cured.

Typical dwell time is 4 seconds at 250 °C. A mildly-activated flux will eliminate the need for removal of corrosive residues in most applications.

14.4 Manual soldering

Fix the component by first soldering two diagonally-opposite end leads. Use a low voltage (24 V or less) soldering iron applied to the flat part of the lead. Contact time must be limited to 10 seconds at up to 300 °C.

When using a dedicated tool, all other leads can be soldered in one operation within 2 to 5 seconds between 270 and 320 °C.

14.5 Package related soldering information

Table 8: Suitability of surface mount IC packages for wave and reflow soldering methods

| Package ^[1] | Soldering method | |
|--|-----------------------------------|-----------------------|
| | Wave | Reflow ^[2] |
| BGA, LBGA, LFBGA, SQFP, TFBGA, VFBGA | not suitable | suitable |
| HBCC, HBGA, HLQFP, HSQFP, HSOP, HTQFP, HTSSOP, HVQFN, HVSON, SMS | not suitable ^[3] | suitable |
| PLCC ^[4] , SO, SOJ | suitable | suitable |
| LQFP, QFP, TQFP | not recommended ^{[4][5]} | suitable |
| SSOP, TSSOP, VSO | not recommended ^[6] | suitable |

[1] For more detailed information on the BGA packages refer to the *(LF)BGA Application Note* (AN01026); order a copy from your Philips Semiconductors sales office.

[2] All surface mount (SMD) packages are moisture sensitive. Depending upon the moisture content, the maximum temperature (with respect to time) and body size of the package, there is a risk that internal or external package cracks may occur due to vaporization of the moisture in them (the so called popcorn effect). For details, refer to the Drypack information in the *Data Handbook IC26; Integrated Circuit Packages; Section: Packing Methods*.

[3] These packages are not suitable for wave soldering. On versions with the heatsink on the bottom side, the solder cannot penetrate between the printed-circuit board and the heatsink. On versions with the heatsink on the top side, the solder might be deposited on the heatsink surface.

[4] If wave soldering is considered, then the package must be placed at a 45° angle to the solder wave direction. The package footprint must incorporate solder thieves downstream and at the side corners.

[5] Wave soldering is suitable for LQFP, QFP and TQFP packages with a pitch (e) larger than 0.8 mm; it is definitely not suitable for packages with a pitch (e) equal to or smaller than 0.65 mm.

[6] Wave soldering is suitable for SSOP and TSSOP packages with a pitch (e) equal to or larger than 0.65 mm; it is definitely not suitable for packages with a pitch (e) equal to or smaller than 0.5 mm.

15. Revision history

Table 9: Revision history

| Rev | Date | CPCN | Description |
|-----|----------|------|--|
| 01 | 20020806 | - | Product data; initial version. Engineering Change Notice 853-2363 28702. |

16. Data sheet status

| Data sheet status ^[1] | Product status ^[2] | Definition |
|----------------------------------|-------------------------------|--|
| Objective data | Development | This data sheet contains data from the objective specification for product development. Philips Semiconductors reserves the right to change the specification in any manner without notice. |
| Preliminary data | Qualification | This data sheet contains data from the preliminary specification. Supplementary data will be published at a later date. Philips Semiconductors reserves the right to change the specification without notice, in order to improve the design and supply the best possible product. |
| Product data | Production | This data sheet contains data from the product specification. Philips Semiconductors reserves the right to make changes at any time in order to improve the design, manufacturing and supply. Changes will be communicated according to the Customer Product/Process Change Notification (CPCN) procedure SNW-SQ-650A. |

[1] Please consult the most recently issued data sheet before initiating or completing a design.

[2] The product status of the device(s) described in this data sheet may have changed since this data sheet was published. The latest information is available on the Internet at URL <http://www.semiconductors.philips.com>.

17. Definitions

Short-form specification — The data in a short-form specification is extracted from a full data sheet with the same type number and title. For detailed information see the relevant data sheet or data handbook.

Limiting values definition — Limiting values given are in accordance with the Absolute Maximum Rating System (IEC 60134). Stress above one or more of the limiting values may cause permanent damage to the device. These are stress ratings only and operation of the device at these or at any other conditions above those given in the Characteristics sections of the specification is not implied. Exposure to limiting values for extended periods may affect device reliability.

Application information — Applications that are described herein for any of these products are for illustrative purposes only. Philips Semiconductors make no representation or warranty that such applications will be suitable for the specified use without further testing or modification.

18. Disclaimers

Life support — These products are not designed for use in life support appliances, devices, or systems where malfunction of these products can reasonably be expected to result in personal injury. Philips Semiconductors customers using or selling these products for use in such applications do so at their own risk and agree to fully indemnify Philips Semiconductors for any damages resulting from such application.

Right to make changes — Philips Semiconductors reserves the right to make changes, without notice, in the products, including circuits, standard cells, and/or software, described or contained herein in order to improve design and/or performance. Philips Semiconductors assumes no responsibility or liability for the use of any of these products, conveys no licence or title under any patent, copyright, or mask work right to these products, and makes no representations or warranties that these products are free from patent, copyright, or mask work right infringement, unless otherwise specified.

Contact information

For additional information, please visit <http://www.semiconductors.philips.com>.

For sales office addresses, send e-mail to: sales.addresses@www.semiconductors.philips.com.

Fax: +31 40 27 24825

Contents

| | | |
|-----------|---|-----------|
| 1 | Description | 1 |
| 2 | Features | 1 |
| 3 | Applications | 1 |
| 4 | Ordering information | 2 |
| 5 | Functional diagram | 2 |
| 6 | Pinning information | 3 |
| 6.1 | Pinning | 3 |
| 6.2 | Pin description | 3 |
| 7 | Functional description | 4 |
| 7.1 | Function table | 4 |
| 8 | Limiting values | 4 |
| 9 | Recommended operating conditions | 4 |
| 10 | Static characteristics | 5 |
| 11 | Dynamic characteristics | 6 |
| 12 | Test figures | 7 |
| 13 | Package outline | 9 |
| 14 | Soldering | 11 |
| 14.1 | Introduction to soldering surface mount packages | 11 |
| 14.2 | Reflow soldering | 11 |
| 14.3 | Wave soldering | 11 |
| 14.4 | Manual soldering | 12 |
| 14.5 | Package related soldering information | 12 |
| 15 | Revision history | 12 |
| 16 | Data sheet status | 13 |
| 17 | Definitions | 13 |
| 18 | Disclaimers | 13 |



PHILIPS

Let's make things better.