

阅读申明

- 1.本站收集的数据手册和产品资料都来自互联网，版权归原作者所有。如读者和版权方有任何异议请及时告之，我们将妥善解决。
- 2.本站提供的中文数据手册是英文数据手册的中文翻译，其目的是协助用户阅读，该译文无法自动跟随原稿更新，同时也可能存在翻译上的不当。建议读者以英文原稿为参考以便获得更精准的信息。
- 3.本站提供的产品资料，来自厂商的技术支持或者使用者的心得体会等，其内容可能存在描述上的差异，建议读者做出适当判断。
- 4.如需与我们联系，请发邮件到marketing@iczoom.com，主题请标有“数据手册”字样。

Read Statement

1. The datasheets and other product information on the site are all from network reference or other public materials, and the copyright belongs to the original author and original published source. If readers and copyright owners have any objections, please contact us and we will deal with it in a timely manner.
2. The Chinese datasheets provided on the website is a Chinese translation of the English datasheets. Its purpose is for reader's learning exchange only and do not involve commercial purposes. The translation cannot be automatically updated with the original manuscript, and there may also be improper translations. Readers are advised to use the English manuscript as a reference for more accurate information.
3. All product information provided on the website refer to solutions from manufacturers' technical support or users the contents may have differences in description, and readers are advised to take the original article as the standard.
4. If you have any questions, please contact us at marketing@iczoom.com and mark the subject with "Datasheets" .

VSC8142, 8145, 8147

VITESSE

2.5G Multi-rate SONET/SDH Transceiver Family



SPECIFICATIONS:

VSC8142

- ▶ Rates: OC-48/12/3, FEC, GbE, Fibre Channel and Other Various Data Rates
- ▶ Power Dissipation: 700mW
- ▶ Selectable Reference Clock Frequency (78MHz or 155MHz)
- ▶ Supply Voltage: 2.5V or Optional 2.5V/3.3V
- ▶ 23mm x 23mm, 208 BGA Package
- ▶ 16-bit LVPECL Parallel Interface
- ▶ Operating Temperature Ranges: -40°C to +85°C Ambient, 0°C to 70°C Ambient

VSC8145

- ▶ Rates: OC-48/-12/-3, FEC, GbE, Fibre Channel and Other Various Data Rates
- ▶ Power Dissipation: 800mW
- ▶ Selectable Reference Clock Frequency (155MHz or 622MHz)
- ▶ Supply Voltage: 2.5V
- ▶ 21mm x 21mm, 156 BGA Package
- ▶ 4-bit LVDS Parallel Interface
- ▶ Operating Temperature Ranges: -40°C to +85°C Ambient, 0°C to 70°C Ambient

VSC8147

- ▶ Rates: OC-48, FEC
- ▶ Power Dissipation: 800mW
- ▶ Supply Voltage: 2.5V
- ▶ 14mm x 14mm, 100-pin PQFP Package
- ▶ 4-bit LVDS Parallel Interface
- ▶ Operating Temperature Ranges: -40°C to +85°C Ambient, 0°C to 70°C Ambient

FEATURES:

- ▶ OC-48/-12/-3, FEC, GbE, Fibre Channel and Other Various Data Rates
- ▶ Integrated Clock Recovery and Clock Multiplier Units
- ▶ Wide Ranging PLLs with Bypass Capabilities
- ▶ Low-speed Bit Order Swap (MSB/LSB)
- ▶ On-board FIFO with Auto-reset Function
- ▶ High-speed Clock Output Power-down Option
- ▶ LOS Detect with Auto-lock to Reference Clock
- ▶ Facility, Equipment, and Split Loopback Modes
- ▶ 0.18_μ CMOS Technology

APPLICATIONS:

- ▶ SONET/SDH Systems
- ▶ DWDM Systems
- ▶ Optical Crossconnects
- ▶ Optical Test Equipment

VSC8142, 8145, 8147

2.5G Multi-rate SONET/SDH Transceiver Family

GENERAL DESCRIPTION:



The VSC8142, VSC8145 and VSC8147 are extended multi-rate transceivers with integrated Clock Recovery Unit (CRU) and Clock Multiplier Unit (CMU) for use in SONET/SDH, DWDM, and other optical transport systems. The devices perform all required serialization and deserialization functions for OC-48, OC-12, OC-3, FEC, Gigabit Ethernet, Fibre Channel and FDDI/Fast Ethernet data rates.

The integrated CRU Phase Locked Loop (PLL) recovers the high-speed clock from the input Non-Return to Zero (NRZ) data signal. The integrated CMU PLL multiplies a low-speed reference clock to provide the high-speed serial line clock for internal logic and output retiming. Both CRU and CMU can be bypassed to accommodate rates not supported by the PLLs. The parallel interface incorporates an on-board FIFO with auto-reset to eliminate interfacing issues. The devices support serial loopback as well as Facility, Equipment, and Split loopback modes.

The VSC8142, VSC8145 and VSC8147 exceed the Telecordia and ITU-T standards for jitter generation, tolerance and transfer providing ample design margin. The typical 800mW power dissipation, along with the thermally-enhance packages, eliminates the need for external heatsinks and allow the devices to be used in diverse operating environments. All device are available in commercial and industrial temperature ranges.

BLOCK DIAGRAM:

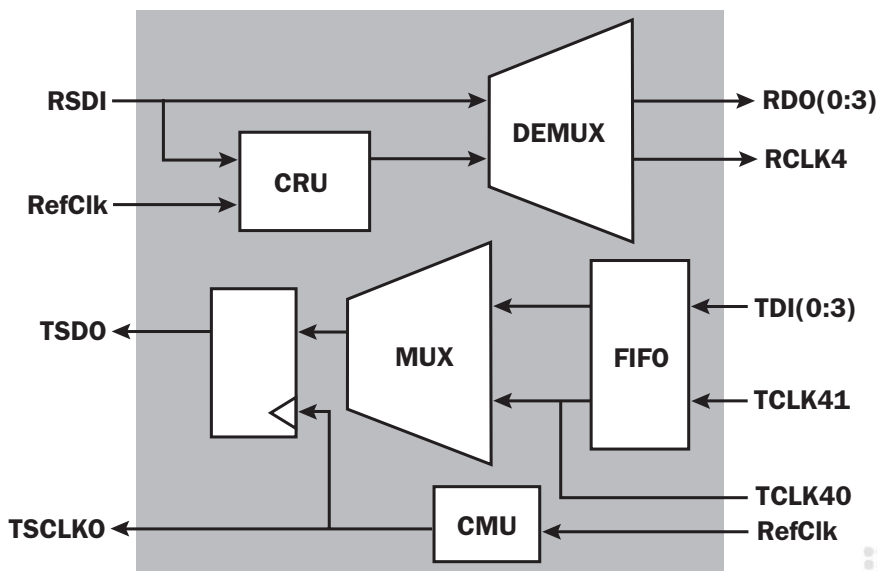

For more information on Vitesse products, visit the Vitesse web site at www.vitesse.com or contact Vitesse Sales at (800) VITESSE or sales@vitesse.com

BENEFITS:

- ▶ Full SONET/SDH Jitter Compliance:
 - Low Jitter Generation: less than 5mUI (typical)
 - High Jitter Tolerance: exceeds 2x the SONET mask
- ▶ Wide-ranging PLLs that not only Provide Support for the Standard SONET/SDH Rates, but also for:
 - Fibre Channel, 2xFibre Channel
 - Gigabit Ethernet
 - FEC
 - FDDI
 - Fast Ethernet
- ▶ Integrated CRU and CMU can be Bypassed if an External CDR is Required, (e.g. the All-Rate/Adaptive VSC8123 CDR)
- ▶ The Order of the MSB and LSB on the Low-speed Interfaces can be Reversed, Giving the Designer Increased Flexibility When Laying Out the Board
- ▶ On-board FIFO Auto-Reset Function Eliminates the Need to use an External Logic
- ▶ Loss of Signal Detection on High-speed Data Inputs for Robust Line Monitoring Support
- ▶ Automatic Lock to Reference Clock on LOS Detection Provides Continuous Clocking for Upstream Devices
- ▶ Integrated High-speed and Low-speed Test Capabilities Provide System Diagnostic Support

VITESSE

741 Calle Plano
Camarillo, CA 93012, USA
Tel: +1 805.388.3700
Fax: +1 805.987.5896
www.vitesse.com