

阅读申明

- 1.本站收集的数据手册和产品资料都来自互联网，版权归原作者所有。如读者和版权方有任何异议请及时告之，我们将妥善解决。
- 2.本站提供的中文数据手册是英文数据手册的中文翻译，其目的是协助用户阅读，该译文无法自动跟随原稿更新，同时也可能存在翻译上的不当。建议读者以英文原稿为参考以便获得更精准的信息。
- 3.本站提供的产品资料，来自厂商的技术支持或者使用者的心得体会等，其内容可能存在描述上的差异，建议读者做出适当判断。
- 4.如需与我们联系，请发邮件到marketing@iczoom.com，主题请标有“数据手册”字样。

Read Statement

1. The datasheets and other product information on the site are all from network reference or other public materials, and the copyright belongs to the original author and original published source. If readers and copyright owners have any objections, please contact us and we will deal with it in a timely manner.
2. The Chinese datasheets provided on the website is a Chinese translation of the English datasheets. Its purpose is for reader's learning exchange only and do not involve commercial purposes. The translation cannot be automatically updated with the original manuscript, and there may also be improper translations. Readers are advised to use the English manuscript as a reference for more accurate information.
3. All product information provided on the website refer to solutions from manufacturers' technical support or users the contents may have differences in description, and readers are advised to take the original article as the standard.
4. If you have any questions, please contact us at marketing@iczoom.com and mark the subject with "Datasheets" .

TVP6000C Data Manual

NTSC/PAL Digital Video Encoder

***SLAS184
July 1998***



Printed on Recycled Paper

IMPORTANT NOTICE

Texas Instruments and its subsidiaries (TI) reserve the right to make changes to their products or to discontinue any product or service without notice, and advise customers to obtain the latest version of relevant information to verify, before placing orders, that information being relied on is current and complete. All products are sold subject to the terms and conditions of sale supplied at the time of order acknowledgement, including those pertaining to warranty, patent infringement, and limitation of liability.

TI warrants performance of its semiconductor products to the specifications applicable at the time of sale in accordance with TI's standard warranty. Testing and other quality control techniques are utilized to the extent TI deems necessary to support this warranty. Specific testing of all parameters of each device is not necessarily performed, except those mandated by government requirements.

CERTAIN APPLICATIONS USING SEMICONDUCTOR PRODUCTS MAY INVOLVE POTENTIAL RISKS OF DEATH, PERSONAL INJURY, OR SEVERE PROPERTY OR ENVIRONMENTAL DAMAGE ("CRITICAL APPLICATIONS"). TI SEMICONDUCTOR PRODUCTS ARE NOT DESIGNED, AUTHORIZED, OR WARRANTED TO BE SUITABLE FOR USE IN LIFE-SUPPORT DEVICES OR SYSTEMS OR OTHER CRITICAL APPLICATIONS. INCLUSION OF TI PRODUCTS IN SUCH APPLICATIONS IS UNDERSTOOD TO BE FULLY AT THE CUSTOMER'S RISK.

In order to minimize risks associated with the customer's applications, adequate design and operating safeguards must be provided by the customer to minimize inherent or procedural hazards.

TI assumes no liability for applications assistance or customer product design. TI does not warrant or represent that any license, either express or implied, is granted under any patent right, copyright, mask work right, or other intellectual property right of TI covering or relating to any combination, machine, or process in which such semiconductor products or services might be or are used. TI's publication of information regarding any third party's products or services does not constitute TI's approval, warranty or endorsement thereof.

Contents

<i>Section</i>	<i>Title</i>	<i>Page</i>
1	Introduction	1-1
1.1	Features	1-1
1.2	Applications	1-2
1.3	Functional Block Diagram	1-2
1.4	Terminal Assignments	1-3
1.5	Ordering Information	1-4
1.6	Terminal Functions	1-4
2	Detailed Description	2-1
2.1	Initialization	2-1
2.2	I ² C Interface	2-3
2.3	Data Manager	2-4
2.4	Scaling Processor	2-5
2.5	Video Encoder	2-6
2.5.1	Luminance Encoding	2-6
2.5.2	Luminance Low-Pass and Interpolation Filter	2-6
2.5.3	Cross Color Reduction Filter	2-8
2.5.4	Chrominance Encoding	2-8
2.6	Closed Caption	2-9
2.7	Clock Generation	2-11
2.8	Analog Output	2-11
2.9	Video Port Interface	2-12
2.9.1	RCV1	2-12
2.9.2	RCV2	2-12
2.9.3	RCM1	2-12
2.9.4	RCM2	2-13
2.10	Modes of Operation	2-13
2.10.1	Master Mode	2-13
2.10.2	Slave Mode	2-13
2.10.3	Demand Mode	2-14
2.10.4	Genlock Mode	2-14
2.11	Register Descriptions	2-15
2.11.1	DEV_ID	2-17
2.11.2	REV_ID	2-17
2.11.3	STATUS	2-17
2.11.4	F_CONTROL	2-18
2.11.5	C_PHASE	2-19
2.11.6	GAIN_U	2-19
2.11.7	GAIN_V	2-19
2.11.8	BLACK_LEVEL	2-19
2.11.9	BLANK_LEVEL	2-20

Contents (Continued)

<i>Section</i>	<i>Title</i>	<i>Page</i>
2.11.10	GAIN_Y	2-20
2.11.11	X_COLOR	2-20
2.11.12	M_CONTROL	2-21
2.11.13	BSTAMP	2-21
2.11.14	S_CARR1, 2, 3, 4	2-22
2.11.15	LINE21_O0	2-23
2.11.16	LINE21_O1	2-23
2.11.17	LINE21_E0	2-23
2.11.18	LINE21_E1	2-23
2.11.19	LN_SEL	2-23
2.11.20	SYN_CTRL0	2-24
2.11.21	RCM_L21	2-26
2.11.22	HTRIGGER0	2-28
2.11.23	HTRIGGER1	2-28
2.11.24	VTRIGGER	2-28
2.11.25	BMRQ	2-29
2.11.26	EMRQ	2-29
2.11.27	BEMRQ	2-29
2.11.28	BRCV	2-29
2.11.29	ERCV	2-30
2.11.30	BERCV	2-30
2.11.31	FLEN	2-30
2.11.32	FAL	2-30
2.11.33	LAL	2-31
2.11.34	FLAL	2-31
2.11.35	SYN_CTRL1	2-31
2.11.36	SCM	2-32
2.11.37	SLPF	2-32
2.11.38	SPPL	2-33
2.11.39	SLPH	2-33
2.11.40	DLPF	2-33
2.11.41	DPPL	2-33
2.11.42	DLPH	2-34
2.11.43	VDTAL	2-34
2.11.44	VDTAH	2-34
2.11.45	HDTAL	2-34
2.11.46	HDTAH	2-35
2.11.47	VOFS	2-35
2.11.48	HOFS	2-35
2.11.49	NLR	2-35
2.11.50	TEST1, TEST2, TEST3	2-35

Contents (Continued)

<i>Section</i>	<i>Title</i>	<i>Page</i>
3	Electrical Characteristics	3-1
3.1	Absolute Maximum Ratings Over Operating Free-Air Temperature Range	3-1
3.2	Recommended Operating Conditions	3-1
3.3	DC Electrical Characteristics, $T_A = 25^\circ\text{C}$, $DV_{DD} = AV_{DD} = 5\text{ V}$	3-1
3.4	AC Electrical Characteristics, $T_A = 25^\circ\text{C}$, $DV_{DD} = AV_{DD} = 5\text{ V}$	3-2
3.5	Timing Requirements	3-2
3.6	Demand Mode Timing	3-2
3.7	Switching Characteristics	3-2
A	Example Register Settings	A-1
B	Mechanical Data	B-1

List of Illustrations

<i>Figure</i>	<i>Title</i>	<i>Page</i>
1-1	Terminal Assignments	1-3
2-1	Block Diagram	2-2
2-2	I ² C Start and Stop Conditions	2-3
2-3	I ² C Access Cycles	2-3
2-4	I ² C Write Cycle	2-4
2-5	I ² C Read Cycle	2-4
2-6	Luma Path Frequency Response	2-7
2-7	Luma Cross Color Reduction Filter	2-7
2-8	Chroma Path Frequency Response	2-9
2-9	NTSC CCIR601 Rate Closed Caption Line	2-10
2-10	PAL CCIR601 Pixel Rate Closed Caption Line	2-10
2-11	NTSC Square Pixel Rate Closed Caption Line	2-11
2-12	PAL Square Pixel Rate Closed Caption Line	2-11
2-13	Output Filter	2-12
2-14	Transmission Timing	2-15
3-1	Data Setup and Hold Timing	3-3
3-2	Demand Mode Timing	3-3

List of Tables

<i>Table</i>	<i>Title</i>	<i>Page</i>
2-1	16-Bit Video Port YUV 4:2:2	2-5
2-2	8-Bit Multiplexed Video Port CCIR656 YUV 4:2:2	2-5
2-3	100/100 Color Bar in Twos Complement	2-5
2-4	Master Mode	2-13
2-5	Crystal Frequencies	2-13
2-6	Slave Mode Signals	2-14
2-7	Base Addresses	2-15
2-8	Register Bit Allocation Map	2-15
2-9	Input Format and Data Sampling	2-18
2-10	Chroma Channel Delays	2-20
2-11	Total Horizontal Pixel Selection	2-22
2-12	S_CARR Values	2-22
2-13	RCV1 Pin Configurations	2-25
2-14	RCV1 Symbols and Signal Descriptions	2-25
2-15	RCV2 Pin Configurations	2-25
2-16	RCV2 Symbols and Signal Descriptions	2-26
2-17	RCM1 Output Signals	2-27
2-18	RCM2 Pin Configurations	2-27
2-19	Encoding Setting	2-27
2-20	Phase Reset Modes	2-28
2-21	Active Video Modes	2-32

1 Introduction

The TVP6000 is a digital video encoder designed for multimedia systems requiring high-quality flicker free display of computer graphics, video, and internet content.

The TVP6000 provides advanced horizontal and vertical scaling for overscan compensation. It features a 3 tap antiflicker filter. The encoder has different filters in the luma and the chroma channels. Additionally, the output is interpolated to twice the pixel frequency. All of these features combine to produce a high-quality display of non-interlaced data on a traditional interlaced TV.

The TVP6000 converts Y Cb Cr video data to base-band analog video output. The input can come from a video decoder (such as the TI TVP5010/TVP5020), a 3D graphics controller (such as the TI 4020), or a MPEG decoding device. Simultaneous composite and S-video (Y, C separated) provides high-quality video output.

1.1 Features

- Digital Input Formats:
 - YUV 4:2:2 on a 16-Bit Port
 - CCIR-656 YUV 4:2:2 on an 8-Bit Port
 - YUV 4:2:2 on an 8-Bit Port
- CCIR601 or Square Pixel Operation
- Analog Output Formats:
 - NTSC-M
 - PAL-B,D,G,H,I
 - PAL-M
 - PAL-N
 - PAL-Nc
- Simultaneous S-Video and CVBS (Composite Baseband Video) Output
- 2x Over-Sampling
- 3-Tap Antiflicker Filter
- Triple 10-Bit DACs
- Overscan Compensation
- Programmable Video Port Interface
- Supports Master, Slave, CCIR656 and Demand Mode Video Port Interface
- Programmable Blank Level, Black Level, and Color Burst Amplitude
- Programmable Luminance and Chrominance Gains
- Programmable Subcarrier Frequency
- Programmable SCH
- Subcarrier Genlock Capability

- Programmable Luminance Delay
- I²C Serial Interface
- On Chip Color Bar Generation
- Closed Caption Support
- Software Detection of TV Connection
- On Chip Voltage Reference
- Cross Color Reduction Filter
- Power Down Mode
- 80-pin TQFP Package
- 5-V Operation
- Supports PC98 Hardware Design Specification
- SMPTE 170M NTSC Composite Video Specification Compliant
- CCIR624/CCIR601 PAL Composite Video Specification Compliant

1.2 Applications

- Digital Entertainment/ Set Top Box
- Internet PC
- Internet Appliance
- PC-to-TV Appliance
- Digital Video Disk (DVD)
- Digital Video Camera

1.3 Functional Block Diagram

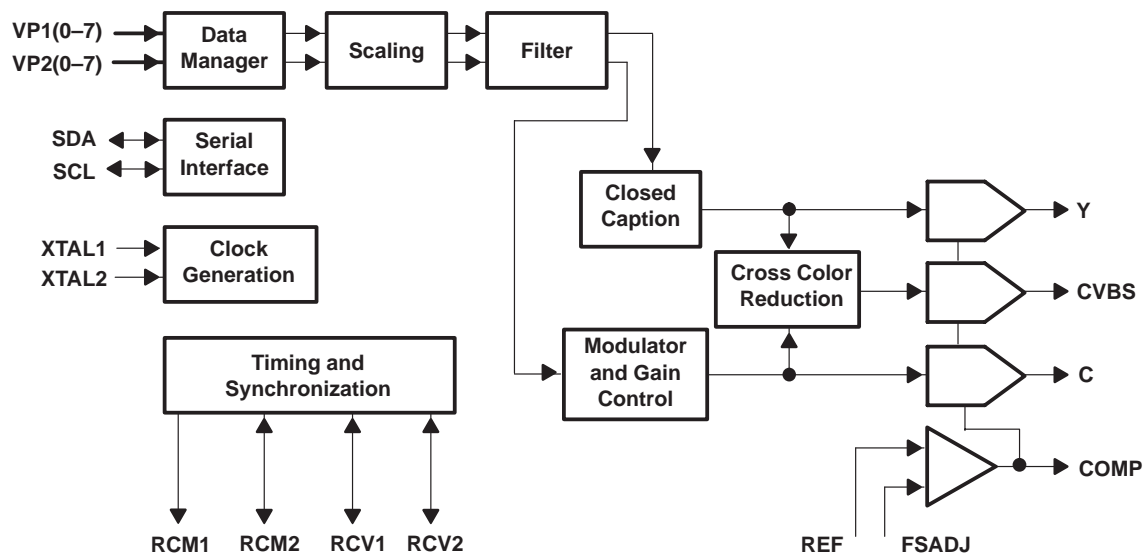

1.4 Terminal Assignments

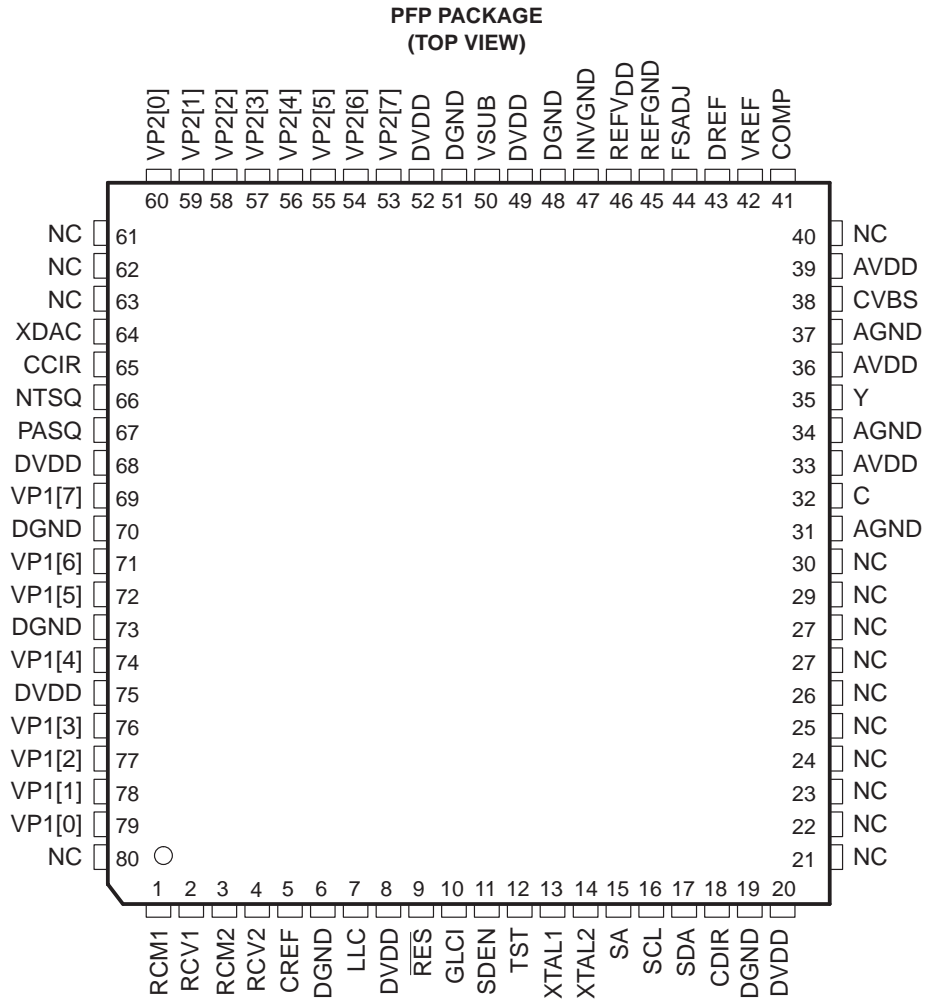

Figure 1–1. Terminal Assignments

1.5 Ordering Information

Device

TVP6000CPFP

PFP: Plastic Flat Pack With Power Pad

1.6 Terminal Functions

TERMINAL		I/O	DESCRIPTION
NAME	NO.		
AGND	31,34,37		Analog ground
AVDD	33,36,39		Analog power supply
C	32	O	Chrominance analog output signal for S-video output
CCIR	65	O	External clock source select. CCIR can be programmed to select different external clock sources. When CCIR = 1, the encoder is set to CCIR601 mode. For detailed programming information, refer to Table 2–11.
CDIR	18	I	Clock direction input. When CDIR = 0, LLC and CREF are outputs. When CDIR = 1, LLC and CREF are inputs.
COMP	41	I/O	Compensation pin for the internal reference amplifier. A 0.1- μ F capacitor should be connected between COMP and AVDD.
CREF	5	I/O	Clock reference signal
CVBS	38	O	Composite video output signal
DGND	6,19,48, 51,70,73		Digital ground
DREF	43	I/O	Test pin. For normal applications no connect.
DVDD	8,20,49, 52,68,75		Digital power supply
FSADJ	44	I/O	Full scale adjust control. A 264- Ω resistor should be connected between FSADJ and AGND to control the full-scale output current on the analog outputs.
GLCI	10	I	Genlock control input. GLCI is used for communicating with TVP5xxx decoder series.
INVGND	47		INVGND should be connected to AGND for normal applications.
LLC	7	I/O	Line locked clock. One of the 24.54 MHz, 27.00 MHz, or 29.5 MHz clocks for different standards and pixel rates.
NC	21–30,40, 61–63,80		No connect
NTSQ	66	O	External clock source select. NTSQ can be programmed to select different external clock sources. When NTSQ = 1, the encoder is set to NTSC square pixel mode. For detailed programming information, refer to Table 2–11.
PASQ	67	O	External clock source select. PASQ can be programmed to select different external clock sources. When PASQ = 1, the encoder is set to PAL square pixel mode. For detailed programming information, refer to Table 2–11.

1.6 Terminal Functions (Continued)

TERMINAL		I/O	DESCRIPTION
NAME	NO.		
RCM1	1	O	Programmable video vertical timing signal. For detailed programming information, see the RCM_L21 register definition.
RCM2	3	I/O	Programmable video horizontal timing signal (can also be programmed for horizontal active video signal). For detailed programming information, see RCM_L21 register definition.
RCV1	2	I/O	Programmable video vertical timing signal. For programming information, see SYN_CTRL0 register definition.
RCV2	4	I/O	Programmable video horizontal timing signal (can also be programmed for horizontal active video signal). For detailed programming information, see SYN_CTRL0 register definition.
VREF	42	I/O	Test pin. VREF can be used for bandgap voltage output. For normal operation no connection.
REFGND	45		Reference ground of output DACs. REFGND should be connected to AGND.
REFV _{DD}	46		Reference power supply of the DACs. REFV _{DD} should be connected to AV _{DD} .
RES	9	I	Reset input, active low
SA	15	I	I ² C slave address select
SCL	16	I/O	I ² C serial clock input. Maximum clock rate of 400 kHz.
SDA	17	I/O	I ² C serial data line
SDEN	11	I	Test pin. For normal applications connect to DGND.
TST	12	I	Test pin. For normal applications connect to DGND.
VP1[7:0]	69,71,72, 74,76–79	I	Y input port in 16-bit mode. For 8-bit multiplexed mode, VP1[7:0] is either the YUV multiplexed port or should be left unconnected based on the FMT(2) register bit.
VP2[7:0]	53–60	I	UV input port in 16-bit mode. For 8-bit multiplexed mode, VP2[7:0] is either the YUV multiplexed port or should be left unconnected based on the FMT(2) register bit.
VSUB	50		VSUB should be connected to AGND.
XDAC	64	I	XDAC sets the initial mode of operation for the output DACs immediately after reset. If XDAC = GND the DACs will be in normal operation mode after reset. If XDAC = V _{DD} , the DACs will be in power down mode.
XTAL1	13	I	Crystal or oscillator input. CMOS input levels
XTAL2	14	I	Crystal input. Crystal is connected between XTAL1 and XTAL2.
Y	35	O	Luminance analog output signal for S-video output

2 Detailed Description

The TVP6000 is a digital video encoder designed for systems requiring high-quality display of computer graphics, video, video conferencing, and Internet content. It is designed to convert a digital video input data stream into NTSC or PAL composite video output. Digital input formats include 8 or 16 bit YUV 4:2:2 or 8 bit CCIR-656 YUV. Analog output formats are NTSC and PAL.

The encoder provides picture quality enhancement features such as overscan compensation, which allows up to a 12.5% down scaling of pixels (horizontal) and lines (vertical) to allow fitting a VGA frame on a NTSC. A 3-tap antiflicker filter greatly reduces annoying flicker associated with displaying progressive scan graphics data or text on an interlace display, like TV. The output has simultaneous S-video and composite baseband video (CVBS) via three 10-bit DACs. Programmable features such as blank levels, color burst amplitude, luminance and chrominance gains, subcarrier frequency, luminance delay allow for easy optimization of picture quality and subcarrier genlock capability when used with a compatible video decoder provides accurate color reproduction even with nonstandard or unstable video sources such as a VCR.

See Figure 2-1 for an overview of the major functional blocks of the TVP6000.

2.1 Initialization

Upon power up, the TVP6000 is initialized by the internal logic to display a color bar. With this feature, the TVP6000 is able to demonstrate basic functionality while using only a 27-MHz clock signal at the LLC pin or the XTAL1 and XTAL2 crystal pins. No software programming is required for this initial operation. This serves as a quick diagnostic tool during the initial debug of a system.

The DACs can also be optionally turned off immediately after reset by connecting the XDAC pin (pin 64) to V_{DD} if the initial color bar display is not desired. In this case, video is not output after reset. See Section 2.11, *Register Descriptions* for details about the default values immediately after power up.

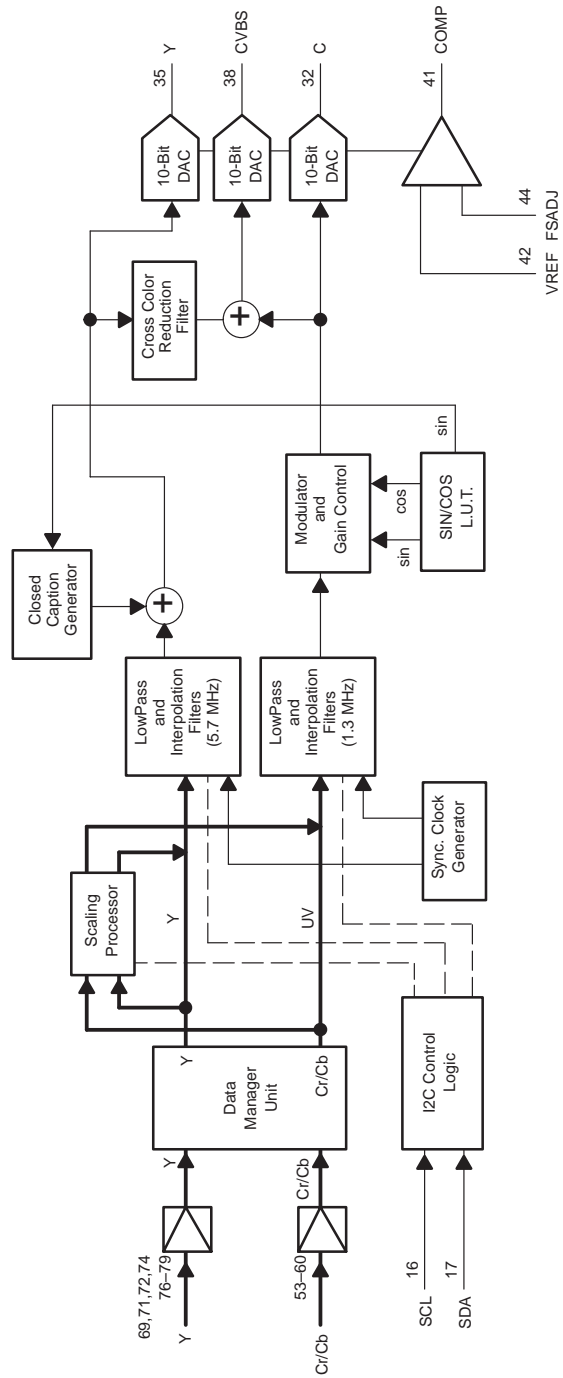

Figure 2-1. Block Diagram

2.2 I²C Interface

The I²C interface is used to access the internal registers of the TVP6000 encoder. This two pin interface consists of one clock line, SCL, and one serial data line, SDA. The basic I²C access cycles are shown in Figure 2–3.

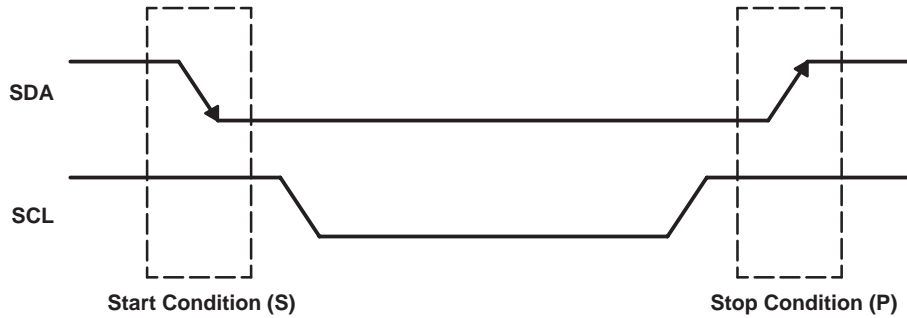

Figure 2–2. I²C Start and Stop Conditions

The basic access cycle consists of the following:

1. A start condition
2. A slave address cycle
3. A subaddress cycle
4. Any number of data cycles
5. A stop condition

The start and stop conditions are shown in Figure 2–2. The high-to-low transition of SDA while SCL is high, defines the start condition. The low-to-high transition of SDA while SCL is high, defines the stop condition. Each cycle, data or address, consists of 8 bits of serial data followed by one acknowledge bit generated by the receiving device. Thus, each data/address cycle contains nine bits as shown in Figure 2–3.

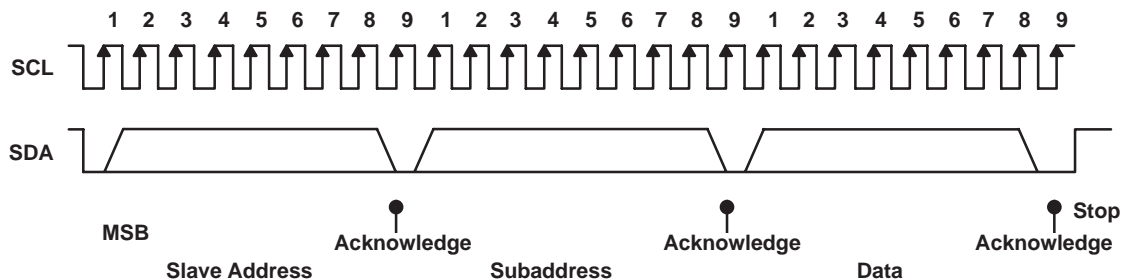

Figure 2–3. I²C Access Cycles

As indicated in Figure 2–3, following a start condition, each I²C device decodes the slave address. The TVP6000 responds with an acknowledge by pulling the SDA line low during the ninth clock cycle, if it decodes the address as its address. During subsequent subaddress and data cycles, the TVP6000 responds with an acknowledge as shown in Figure 2–3. The subaddress is auto-incremented after each data cycle.

The transmitting device must not drive the SDA signal during the acknowledge cycle so that the receiving device may drive the SDA signal low. The not acknowledge, \bar{A} , condition is indicated by the master by keeping the SDA signal high just before it asserts the stop, P, condition. This sequence terminates a read cycle as shown in Figure 2–5.

The slave address consists of 7 bits of address along with 1 bit of read/write information as shown in Figures 2–4 and 2–5. For the TVP6000, the possible slave addresses (including the read/write bit) are 0x40 or 0x42 for write cycles or 0x41 and 0x43. Refer to Table 2–7 for additional base address information.

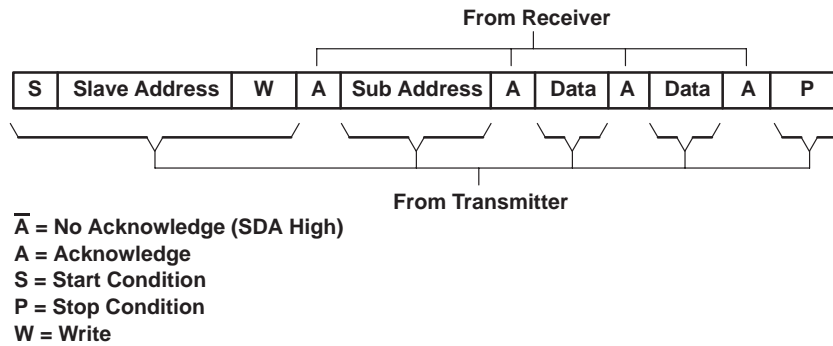

Figure 2–4. I²C Write Cycle

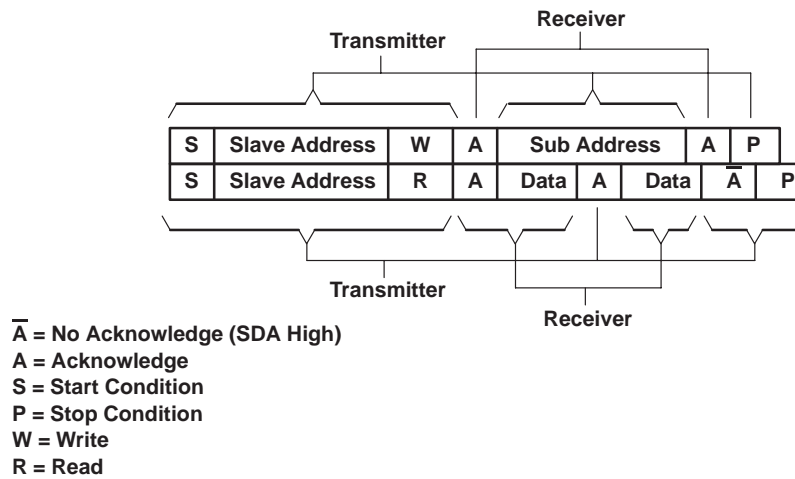

Figure 2–5. I²C Read Cycle

2.3 Data Manager

The data manager resides at the very beginning of the processing pipeline. It receives the Y Cb Cr pixel data from the pixel bus and converts it to its internal YUV representation. Register F_CONTROL at subaddress 3A and the SCN bit of the SCM register at subaddress 90 define the function of the data manager.

The data manager can receive data on either an 8-bit or 16-bit video port. In the 8-bit format, it receives data at port VP1 or VP2 (both 8-bits wide) depending on register bit FMT2, at every rising edge of LLC if scan conversion is disabled, and at every (rising and falling) edge of LLC if scan conversion is enabled. In the 16-bit format, it receives luminance information on the VP1 port and chrominance information on the VP2 port, at alternate rising edges of LLC (qualified by CREF) if scan conversion is disabled, or at every rising edge of LLC if scan conversion is enabled. Additionally, the data manager can generate pixels internally for a 100/100 color bar if the CBAR bit is set. The Y, U, and V values for this color bar are shown in Table 2–3.

Table 2–1. 16-Bit Video Port YUV 4:2:2

TIME	0	1	2	3	4	5	6	7
VP1[7:0]	Y0		Y1		Y2		Y3	
VP2[7:0]	Cb0		Cb1		Cb2		Cb3	
Luma pixel number	0		1		2		3	
Chroma pixel number	0				2			

Table 2–2. 8-Bit Multiplexed Video Port CCIR656 YUV 4:2:2

TIME	0	1	2	3	4	5	6	7
VP1[7:0] or VP2[7:0]	Cb0	Y0	Cr0	Y1	Cb2	Y2	Cr2	Y3
Luma pixel number	0		1		2		3	
Chroma pixel number	0				2			

Table 2–3. 100/100 Color Bar in Twos Complement

COLOR	Y (hex)	Cb (hex)	Cr (hex)
White	6B	00	00
Yellow	52	90	12
Cyan	2A	26	90
Green	11	B6	A2
Magenta	EA	4A	5E
Red	D1	DA	70
Blue	A9	70	EE
Black	90	00	00

The SCN bit in the SCM register enables or disables scan conversion. When scan conversion is disabled (SCN = 0), the input scan lines are interlaced at a field rate of 60 Hz for 525-line systems or 50 Hz for 625-line systems. When scan conversion is enabled (SCN = 1), the input scan lines are non-interlaced at a frame rate of 60 Hz or 50 Hz.

2.4 Scaling Processor

The scaling processor scales down the input image in both horizontal and vertical directions. In addition to scaling, the scaling processor filters the image in the vertical direction and removes annoying flickers, which are common when a computer-generated graphics or text, especially a static image, is displayed on TV. The scaling processor uses a 3-tap adaptive filter, whose coefficients are dynamically adjusted on a line-by-line basis to maintain optimal performance.

The scaling processor is enabled by setting the SCN register bit to 1. When scan conversion is enabled, the data manager receives non-interlaced pixel data via the demand mode interface and passes pixel data on to the scaling processor for overscan-compensation processing. The output of the scaling processor feeds the video encoder core for encoding. See Section 2.5, *Video Encoder* for a detailed description.

When the scaling processor is disabled, SCN reset to 0, the data manager receives pixel data via master or slave mode and passes pixel data directly to the video encoder core, bypassing the scaling processor.

The scaling processor, when enabled, is controlled by the following registers: SPPL, DPPL, SLPF, and DLPF. These registers define the size of the image before and after scaling. The SPPL register defines the number of active pixels per line before scaling and the DPPL register defines the number of active pixels per line after scaling. The SLPF register defines the number of active lines before scaling and the DLPF register defines the number of active lines after scaling. Refer to Section 2.11, *Register Descriptions* for additional information on these registers.

Vertical and horizontal over-scan compensation ratios are independently controlled by two pairs of registers. The VDTAH and VDTAL register pair define the vertical scaling ratio and the HDTAH and HDTAL register pair define the horizontal scaling ratio. The scaling ratio equations are given in the register description section. An over-scan compensation ratio up to 12.5% in both vertical and horizontal directions is supported.

When enabled, three modes of vertical scaling and two modes of horizontal scaling are provided for optimal performance of the target application. For computer graphics and text intensive static images, mode 2 vertical scaling (VSC[1:0] = 2) should be used for maximum flicker reduction. For DVD playback, mode 3 (VSC[1:0] = 3) should be used for sharpness. The nearest neighbor mode is provided only for comparison and diagnostic purposes, and should not be used for normal applications.

Finally, the scaled image can be placed on the TV screen at a location defined by the VOFS and HOFS registers. VOFS and HOFS define the location of the upper left corner of the output image. See the definitions of the VOFS and HOFS registers for details.

Note that the SWPF bit is provided for test and diagnostic purposes. For normal applications, this bit must be set to 0 at all times.

2.5 Video Encoder

2.5.1 Luminance Encoding

Programmable gain is first applied to the luminance data output from the data manager or scaling processor depending on whether the TVP6000 is in regular or scan-conversion mode. The luminance gain is defined by the GAIN_Y register at subaddresses 5F and 60. The horizontal sync, vertical sync, and setup insertion are then performed. Both black level and blank level are programmable through the BLACK_LEVEL and BLANK_LEVEL registers at subaddresses 5D and 5E, respectively.

All of the transition edges of the luminance signal such as the sync edges and active video edges are properly shaped and filtered to limit the bandwidth within the standards.

2.5.2 Luminance Low-Pass and Interpolation Filter

After all of the necessary components of the luminance signal have been added, the resultant signal is low-passed and interpolated to a 2x pixel rate. This 2x interpolation simplifies the external analog reconstruction filter design and improves the signal-to-noise ratio. Refer to Figure 2–6 for the filter frequency response.

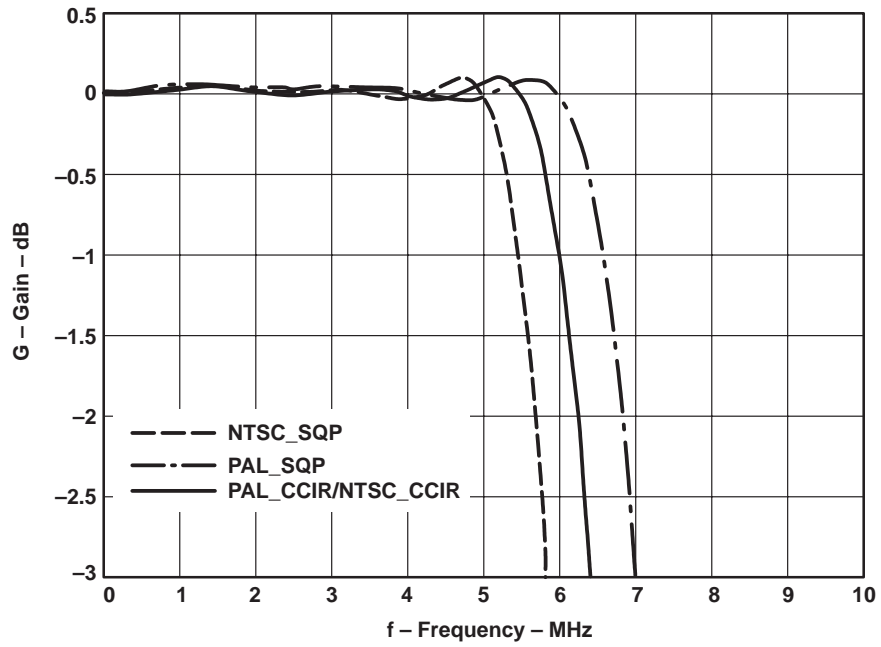

Figure 2-6. Luma Path Frequency Response

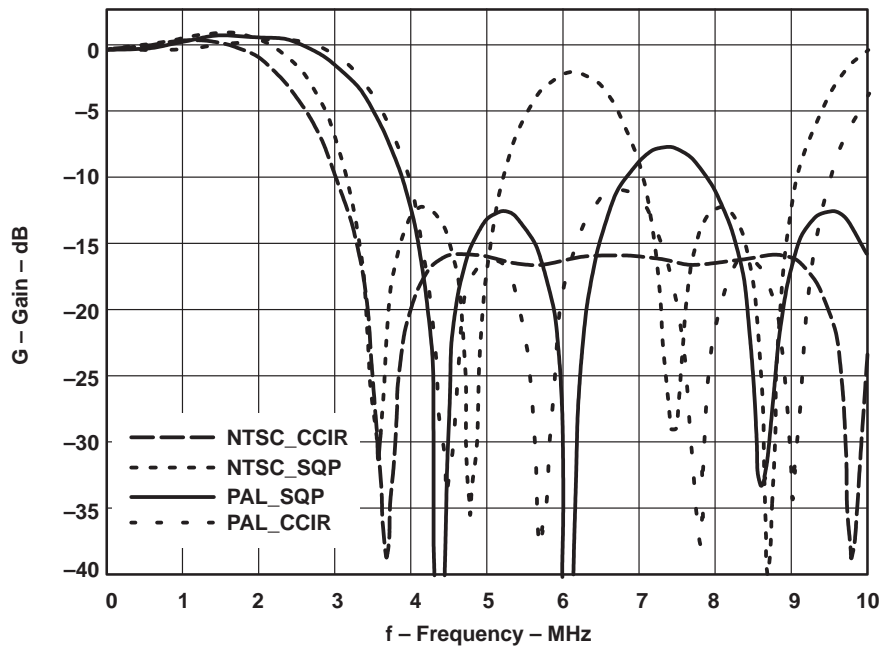

Figure 2-7. Luma Cross Color Reduction Filter

2.5.3 Cross Color Reduction Filter

An optional cross color reduction filter can be applied to the luminance signal before the luminance signal combines with the chrominance signal to form the composite signal. The cross color reduction filter reduces the interference between the luminance and chrominance in the composite signal. The cross reduction filter does not apply to S-video.

2.5.4 Chrominance Encoding

The time-multiplexed U/V signal is adjusted by a pair of programmable gains. The gain for U and the gain for V are independently controlled by the GAIN_U and GAIN_V register bits respectively at subaddresses 5B, 5C, 5D, and 5E. The gain-adjusted signal then passes through a chrominance low-pass filter to limit the bandwidth of the U/V signal. The chrominance low-pass filter can be optionally bypassed by setting the CBW bit of the M_CONTROL register at subaddress 61 to 0. This setting enlarges the bandwidth on U/V for S-video output.

The low-passed U/V signal is then subjected to a 1-to-4 interpolation through an interpolation filter. The data rate for both U and V is now at a 2x pixel rate.

The U and V signals are then quadrature-modulated by the internally generated subcarrier signal to form the chrominance (C) signal. The subcarrier reference signal color burst is inserted right before the active video.

The frequency, the phase of the modulating subcarrier, and the amplitude of the color burst are all programmable. When genlock is disabled (the GLCE bit of the M_CONTROL register set to 0), the subcarrier frequency is controlled by the S_CARR registers at subaddresses 63, 64, 65, and 66. The values of the registers are computed based on the desired subcarrier frequency and the LLC clock using the equation in the register description. Table 2–12 lists the most commonly used values for various standards. When genlock is enabled (GLCE set to 1), the subcarrier frequency is updated once every scan line using the frequency control bits serially shifted in at the GLCI pin.

The C_PHASE register at subaddress 5A controls the phase of the subcarrier. The phase of the color subcarrier is reset to C_PHASE when enabled. Four modes of color subcarrier reset are provided: reset every two lines, every two fields, every eight fields, or at a reset bit input at the GLCI pin if genlock is enabled. Users can use the C_PHASE register to adjust the subcarrier-to-horizontal sync phase. The bits BSTAP[6:0] of the BSTAMP register at subaddress 62 sets the amplitude of the color burst. The PAL bit of the M_CONTROL register enables phase alternation line encoding. A sweeping subcarrier is generated to encode the chrominance signal when the PAL bit is set to 1. Otherwise a normal subcarrier is generated. Phase alternation line refers to an encoding scheme in which the subcarrier alternates between two different phases every scan line. There are two possible alternate sequences and the PALPHS bit of the M_CONTROL register selects one of the sequences.

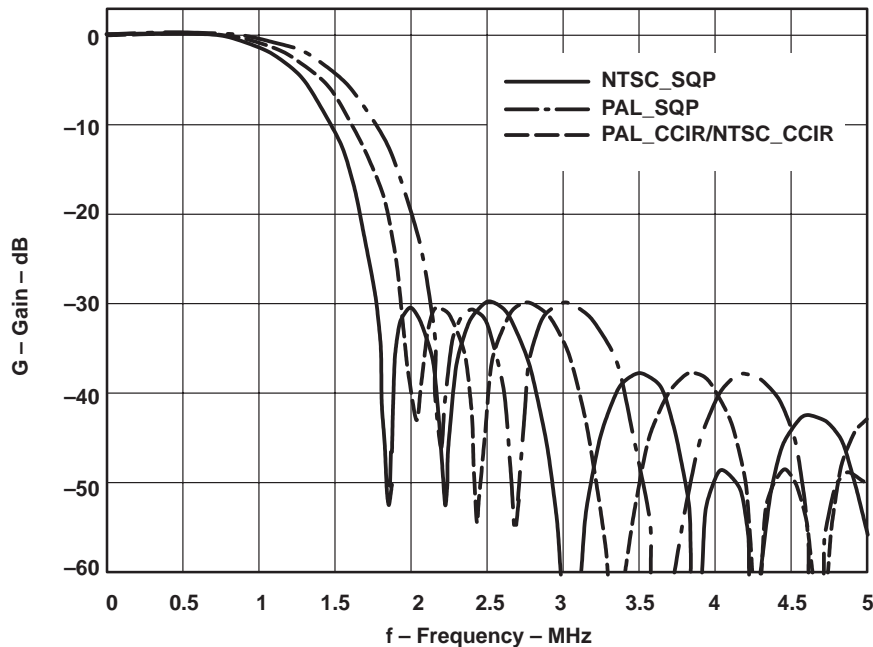

Figure 2-8. Chroma Path Frequency Response

2.6 Closed Caption

The TVP6000 can be programmed to encode closed caption data and extended data in the selected line. The closed caption data are sent to the TVP6000 through the I²C interface. The data stream consists of a seven-bit US-ASCII code and one odd parity bit as shown below.



Closed caption data format

The standard service encodes closed caption only in the odd field, while the extended service encodes closed caption in both fields. L21ENA, when set to 1, enables closed caption encoding in the odd field and L21ENB, when set to 1 enables closed caption encoding in the even field.

The scan line where closed caption is to be encoded is programmable through the SLINE register at subaddress 6B.

Four closed caption data registers contain the closed caption data to be encoded. Registers LINE21_O0 and LINE21_O1 contain the first byte and the second byte of the close caption data to be encoded in the odd field. Registers LINE21_E0 and LINE21_E1 contain the first byte and the second byte of the closed caption data to be encoded in the even field. Immediately after the closed caption data is written to the closed caption data registers either for the odd field or even field, the corresponding closed caption status bit, CCE or CCO in the STATUS register at subaddress 02, is reset to 0 to indicate the closed caption data is available in the closed caption data registers and yet to be encoded. Immediately after the closed caption is encoded, the CCE or CCO bit is set to 1 to indicate the closed caption data has been encoded and is ready to accept new data. The null character is automatically inserted if the closed caption data is not written to the closed caption data registers in time for encoding.

The run-in clock frequency is 503496.5 Hz (32 × line of NTSC). The closed caption data is encoded in the format of non-return to zero (NRZ). Additionally, the data translates to the IRE scale in the following manner: 0= 0 IRE; 1 = 50 IRE.

The following four figures present the parameters of a closed caption line implemented in different standards.

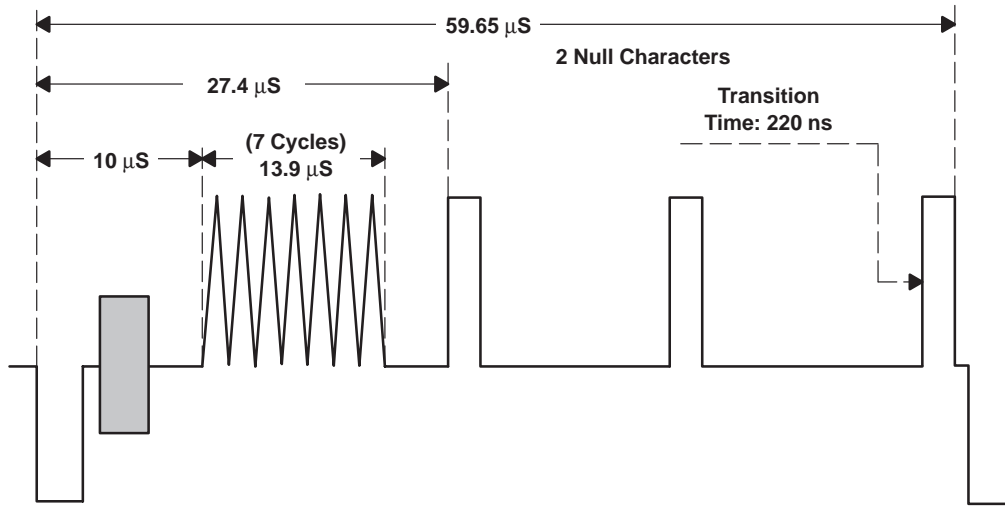

Figure 2-9. NTSC CCIR601 Rate Closed Caption Line

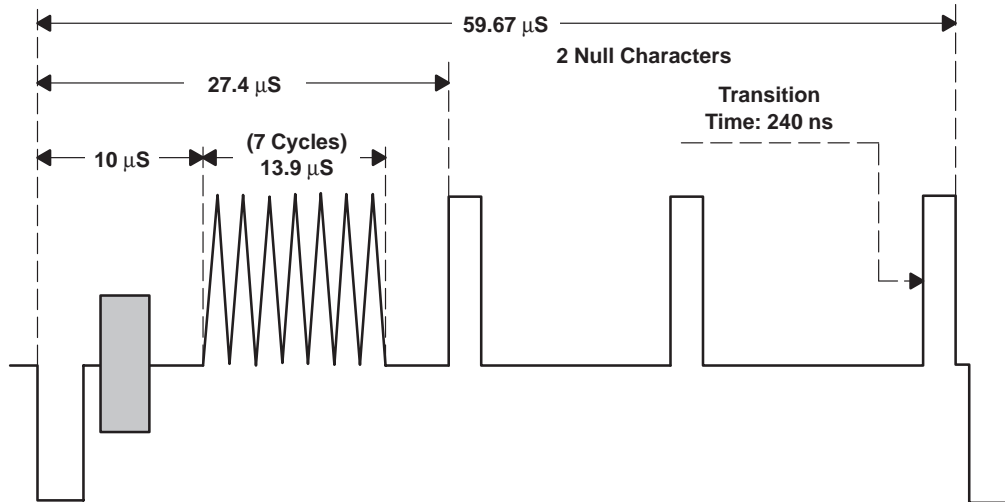

Figure 2-10. PAL CCIR601 Pixel Rate Closed Caption Line

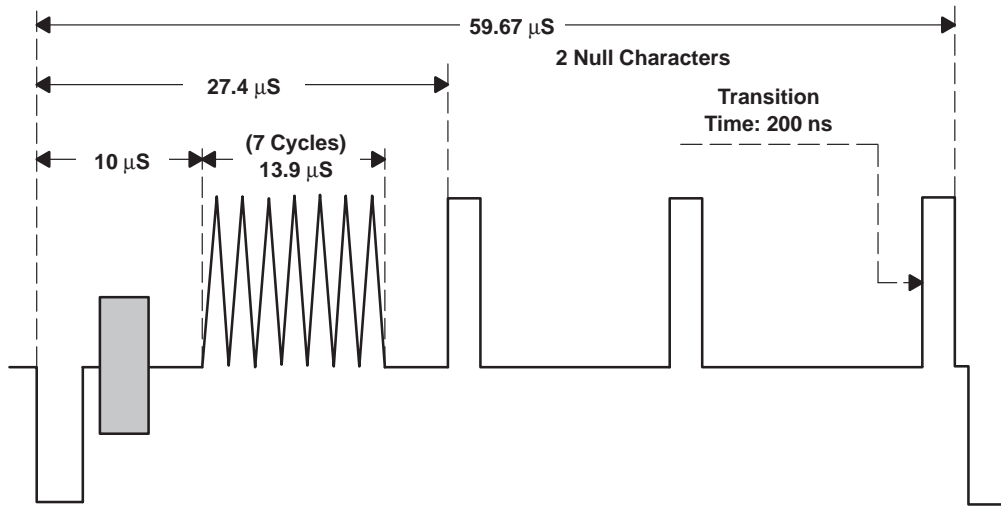

Figure 2–11. NTSC Square Pixel Rate Closed Caption Line

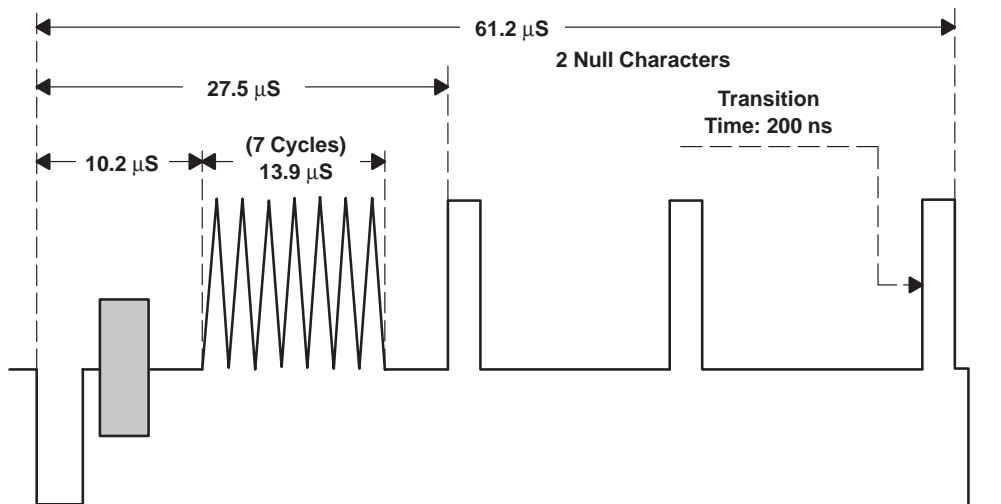

Figure 2–12. PAL Square Pixel Rate Closed Caption Line

2.7 Clock Generation

When the CDIR pin is tied low, the TVP6000 generates the clock from the crystal connected between XTAL1 and XTAL2. Optionally, an oscillator connected to XTAL1 can also be used. The clock is used internally and is also properly buffered and output at the LLC pin. The clock qualifying reference signal, CREF, is also an output in this mode.

When CDIR is tied high, the LLC and CREF pins are inputs. The TVP6000 receives the clock signal from the LLC pin and the clock qualifying reference signal from the CREF pin.

2.8 Analog Output

The TVP6000 supports simultaneous composite and S-video outputs. Additionally, the DACs may be independently turned off via software to minimize power dissipation.

The output DACs are current sources and are optimal for driving a 37.5-Ω load with double 75-Ω termination. A 264-Ω full-scale adjust resistor must be connected between the FSADJ pin and ground.

For cost-sensitive consumer applications, passive low-pass filters are recommended. Figure 2–13 illustrates the termination of the output DACs. An external analog filter, as shown in the figure, is also required.

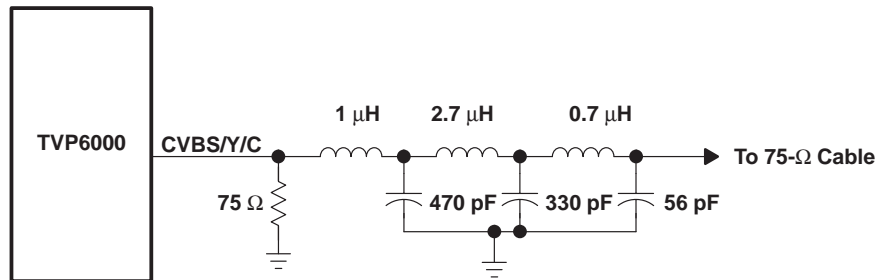

Figure 2–13. Output Filter

2.9 Video Port Interface

The TVP6000 provides a highly flexible video port interface, which users can tailor to fit their target applications. The video port interface consists of four raster controls: RCV1, RCV2, RCM1, and RCM2, an 8-bit or 16-bit pixel port: VP1 and/or VP2, and two clock related signals: LLC and CREF.

2.9.1 RCV1

When scan conversion is disabled (SCN reset to 0), RCV1 can be programmed as an input or an output.

When RCV1 is used as an input, RCV1 can be programmed to receive vertical sync, frame sync, or sequence sync. At the same time, RCV1 can optionally be selected as the source of horizontal sync. The TVP6000 maintains three counters internally; horizontal counter, vertical counter, and field counter in order to generate correct timing for encoding. The horizontal sync input re-triggers the horizontal counter by resetting the horizontal counter to a preset value defined by the HTRIGGER0 and HTRIGGER1 registers.

Similarly, the vertical sync input re-triggers the vertical counter by resetting the vertical counter to a preset value defined by the VTRIGGER0 and VTRIGGER1 registers. The frame sync input forces the field to be the odd field. The sequence sync resets the field to be the first field of the field sequence.

When RCV1 is used as an output, RCV1 can be programmed to generate either vertical sync, frame sync, or sequence sync.

When scan-conversion is enabled (SCN =1), the demand mode video port interface is activated and RCV1 is output only and operates as the new frame indicator.

The polarity of RCV1 is programmable. Refer to the description of the SYN_CTRL0 register for details.

2.9.2 RCV2

When scan conversion is disabled, the RCV2 pin can be programmed as an input or an output.

When RCV2 is used as an input, RCV2 can be used as the horizontal sync based on the HSINSEL bit of the SYN_CTRL0 register. RCV2 is used as the blanking signal if the CBLFV2 bit of the SYN_CTRL0 register is set to 1, regardless whether or not RCV2 has been selected as the horizontal sync.

When scan-conversion is enabled, the demand mode video port interface is activated and RCV2 is output only and operates as the new line indicator.

Similar to RCV1, the polarity of RCV2 is programmable. Refer to the description of the SYN_CTRL0 register for details.

2.9.3 RCM1

RCM1 is always an output. This pin may be programmed to output either vertical sync, frame sync, or sequence sync. Unlike RCV1 and RCV2, the polarity of RCM1 is not programmable. Refer to the description of the RCM_L21 register for details.

2.9.4 RCM2

The RCM2 pin may be configured as an input or an output as shown in Table 2–19. The polarity of the RCM2 pin is programmable via this register as well.

As an output, this pin may be operated as a horizontal sync, composite blank, or a demand mode data request signal. As in input, this pin is always a composite blanking input.

When scan-conversion is enabled, the demand mode video port interface is activated and the RCM2 pin acts as the request output pin.

2.10 Modes of Operation

With a highly programmable video port interface, the TVP6000 may be configured to operate in various modes, each tailored for a target application. In the following sections, several of the most commonly used modes are described.

2.10.1 Master Mode

In the master mode, the TVP6000 generates all of the video timing signals for controlling an external graphics controller or MPEG decoder device. Table 2–4 lists the timing signals that are output from the TVP6000 during master mode.

Table 2–4. Master Mode

PIN NAME	I/O TYPE	DESCRIPTION
LLC	Input/output	Line locked clock; with 2X pixel clock frequency.
CREF	Input/output	Data phase reference clock.
RCM1	Output	Output vertical/field timing, can be programmed as VSO/FSO/FSEQO
RCV1	Output	Output vertical/field timing, can be programmed as VSO/FSO/FSEQO
RCM2	Output	Output horizontal timing, programmed as CBNO. Active duration is defined by registers BMRQ and EMRQ, excluding vertical blanking interval.
RCV2	Output	Output horizontal timing, programmed as HSO. Active duration is defined by registers BRCV and ERCV.

Refer to Table 2–15 and Table 2–17 for the definitions of VSO, FSO, FSEQO, and HSO.

A crystal with the correct frequency according to Table 2–5 should be connected between pins XTAL1 and XTAL2.

Table 2–5. Crystal Frequencies

PIXEL RATE	CLOCK FREQUENCY	
	CCIR-601	27 MHz
Square pixel	24.5454 MHz	29.5 MHz

2.10.2 Slave Mode

In slave mode, all clock and video timing signals are supplied from an external source. The source may be a graphics controller, an MPEG device, or a TV decoder such as the TVP5010/TVP5020 decoders. Table 2–6 lists the signal definitions for slave mode.

Table 2–6. Slave Mode Signals

PIN NAME	I/O TYPE	DESCRIPTION
LLC	Input	Line locked clock with 2X pixel clock frequency. CDIR pin is tied high.
CREF	Input	Data phase reference clock. CDIR pin is tied high.
RCM1	Output	Output Vertical/Field timing, can be programmed as VSO/FSO/FSEQO
RCV1	Input	Can be programmed as VSI/FSI/FSEQI.
RCM2	Input	Programmed as CBNI.
RCV2	Input	Programmed as HSI.

Refer to Table 2–15 and Table 2–17 for the definition of VSO, FSO, FSEQO, HSO, VSI, FSI, FSEQI, CBNI, and HSI.

2.10.3 Demand Mode

Demand mode is an interface specially designed for scan conversion. When scan conversion is enabled, the TVP6000 accepts non-interlaced pixel data, performs signal processing functions which include non-interlace-to-interlace conversion, flicker filtering and overscan-compensation, and outputs interlaced NTSC/PAL video. Due to the nature of the functions that the TVP6000 performs during scan conversion, the bandwidth of the input pixel increases and exceeds what the master and slave mode interface can provide. Demand mode provides extra bandwidth to meet the needs of the TVP6000.

Unlike master mode and slave mode, the video port interface timing for demand mode is decoupled from the timing of the internal encoder core.

The TVP6000 operates in demand mode when it requests data from an external graphics controller or an MPEG device. Demand mode is enabled by setting SCM[0] = 1, the SCN bit.

In demand mode, the TVP6000 asserts the RCM2 pin high to request additional data from the external source and negates the RCM2 pin to stop additional data transfer. Table 2–19 shows how the RCM2 pin may be programmed to operate as a request signal during demand mode. In addition, the NLR register is used to program the threshold where the RCM2 pin is toggled for requests.

2.10.4 Genlock Mode

The TVP6000 may be configured in a genlock mode to an external TV decoder such as the TVP5000/TVP5010 device. This configuration allows the decoder to drive video timing information to the TVP6000 encoder. The genlock mode is used to control clock jitter and thus allows the encoder to generate accurate color burst information.

In this configuration, GLCI pin is connected to the GLCO pin of the decoder, and the line-lock clock pin, LLC, is fed by the decoder main pixel clock output. Moreover, the color sub-carrier information is formatted as a 23-bit binary number and is transmitted serially. The transmission timing diagram is shown in Figure 2–13.

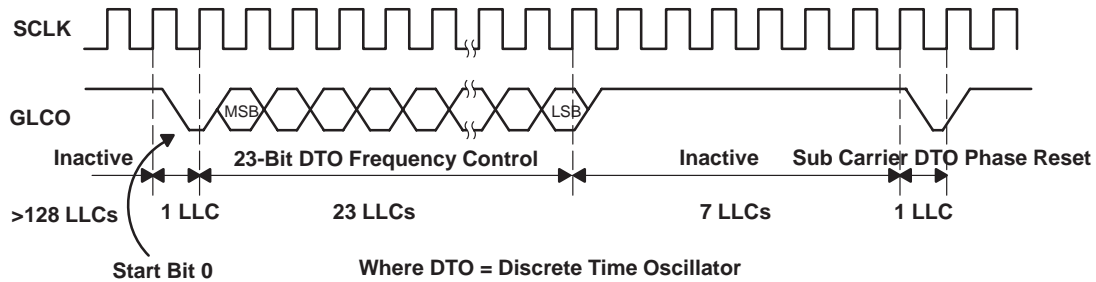

Figure 2–14. Transmission Timing

2.11 Register Descriptions

The TVP6000 is a standard I²C slave device. All of the registers can be written and read through the I²C interface. The I²C base addresses of the TVP6000 are dependent on pin 15 (SA) as listed in Table 2–7.

Table 2–7. Base Addresses

PIN 15	WRITE ADDRESS (hex)	READ ADDRESS (hex)
0	40	41
1	42	43

Table 2–8. Register Bit Allocation Map

REGISTER	R/W	SUB-ADDRESS	BIT7	BIT6	BIT5	BIT4	BIT3	BIT2	BIT1	BIT0
DEV_ID	R	00	Dev id[7:0]							
REV_ID	R	01	Rev id[7:0]							
STATUS	R	02		Scon	Ccon	Cce	Cco	Fsq[2:0]		
Reserved		03–39	Reserved							
F_CONTROL	R/W	3A	Cbar			Fmt2	Y2c	Uv2c	Fmt[1:0]	
Reserved		3B–59	Reserved							
C_PHASE	R/W	5A	Cphase[7:0]							
GAIN_U	R/W	5B	Gu[7:0]							
GAIN_V	R/W	5C	Gv[7:0]							
BLACK_LEVEL	R/W	5D	Gu8	Black[6:0]						
BLANK_LEVEL	R/W	5E	Gv8	Blank[6:0]						
GAIN_Y	R/W	5F	Gy[7:0]							
X_COLOR	R/W	60	0	Xc	Gy8			Lcd[2:0]		
M_CONTROL	R/W	61	Sdown	Cdown	Palphs	0	Glce	Cbw	Pal	Ffrq
BSTAMP	R/W	62	Sqp	Bstap[6:0]						
S_CARR1	R/W	63	Fsc[7:0]							
S_CARR2	R/W	64	Fsc[15:8]							
S_CARR3	R/W	65	Fsc[23:16]							
S_CARR4	R/W	66	Fsc[31:24]							
LINE21_O0	R/W	67	L21o[7:0]							
LINE21_O1	R/W	68	L21o[15:8]							

Table 2–8. Register Bit Allocation Map (Continued)

REGISTER	R/W	SUB-ADDRESS	BIT7	BIT6	BIT5	BIT4	BIT3	BIT2	BIT1	BIT0
LINE21_E0	R/W	69	L21e[7:0]							
LINE21_E1	R/W	6A	L21e[15:0]							
LN_SEL	R/W	6B	Slne[4:0]							
SYN_CTRL0	R/W	6C	Rcv1a	Rcv1b	Hsinel	Orcv1	Prcv1	Cblfv2	Orcv2	Prcv2
RCML21	R/W	6D	Crcm2	Cblfm2	Orcm2	Prcm2	Rcm1a	Rcm1b	L21ena	L21enb
HTRIGGER0	R/W	6E	htrig[7:0]							
HTRIGGER1	R/W	6F	Htrig[10:8]							
VTRIGGER	R/W	70	Presa	Presb	Sblank	Vtrig[4:0]				
BMRQ	R/W	71	Bmrq[7:0]							
EMRQ	R/W	72	Emrq[7:0]							
BEMRQ	R/W	73	Emrq[10:8]				Bmrq[10:8]			
RESERVED		74–76	Reserved							
BRCV	R/W	77	Brcv[7:0]							
ERCV	R/W	78	Ercv[7:0]							
BERCV	R/W	79	Ercv[10:8]				Brcv[10:8]			
FLEN	R/W	7A	Flen[7:0]							
FAL	R/W	7B	Fal[7:0]							
LAL	R/W	7C	Lal[7:0]							
FLAL	R/W	7D			Lal8	Fal8			Flen[9:8]	
SYN_CTRL1	R/W	7E	Esav		Ignp	Free	Blnks	Avm[1:0]		
RESERVED		7F	Reserved							
SCM	R/W	90			Swpf	Hsc[1:0]		Vsc[1:0]		Scn
SLPF	R/W	91	Slpf[7:0]							
SPPL	R/W	92	Sppl[7:0]							
SLPH	R/W	93	Sppl[9:8]				Slpf[9:8]			
DLPF	R/W	94	Dlpf[7:0]							
DPPL	R/W	95	Dppl[7:0]							
DLPH	R/W	96	Dppl[9:8]				Dlpf[9:8]			
VD TAL	R/W	97	Vdta[7:0]							
VDTAH	R/W	98	Vdta[15:8]							
HDTAL	R/W	99	Hdta[7:0]							
HDTAH	R/W	9A	Hdta[15:8]							
VOFS	R/W	9B	Vofs[7:0]							
HOFS	R/W	9C	Hofs[7:0]							
NLR	R/W	9D	Nlr[7:0]							
TEST1	R/W	9E								
TEST2	R/W	9F								
TEST3	R/W	A0								
RESERVED		A1–FF	Reserved							

2.11.1 DEV_ID

Subaddress:00 (Read Only) Default: 0x60

7	6	5	4	3	2	1	0
Dev_ID[7:0]							

This read only register contains the device ID for the TVP6000. The 8-bit device ID for the TVP6000 is 0x60.

2.11.2 REV_ID

Subaddress:01 (Read Only) Default: 0x00

7	6	5	4	3	2	1	0
Rev_ID[7:0]							

This read only register contains the revision ID for the TVP6000. The revision ID identifies different revisions of the device.

2.11.3 STATUS

Subaddress:02 (Read Only)

7	6	5	4	3	2	1	0
	SCON	CCON	CCE	CCO	FSQ[2:0]		

Where:

- SCON S-video connection status
 - 0 Not connected
 - 1 Connected
- CCON Composite video connection status
 - 0 Not connected
 - 1 Connected
- CCE Closed-caption status bit for even field. This bit is set immediately after the data in registers LINE21_E0 and LINE21_E1 has been encoded to closed caption. This bit is reset when both of these registers are written.
- CCO Closed-caption status bit for odd field. This bit is set immediately after the data in registers LINE21_O0 and LINE21_O1 has been encoded to closed caption. This bit is reset when both of these registers are written.
- FSQ[2:0] Field sequence ID. For PAL, all three bits FSQ[2:0] are used whereas for NTSC only bits FSQ[1:0] are meaningful. Furthermore, FSQ(0) represents the odd field when it is a 0 and the even field when it is 1.

2.11.4 F_CONTROL

Subaddress:3A Default: 0x8D

7	6	5	4	3	2	1	0
CBAR			FTM[2]	Y2C	UV2C	FTM[1:0]	

Format control register. This register specifies the input video source and format.

Where:

CBAR	Select video data source
0	Use external video source
1	Use internal color bars
Y2C	Y data format selection
0	The input Y data are in twos complement format
1	The input Y data are in binary format
UV2C	CrCb data format selection
0	The input CrCb data is in twos complement format
1	The inputCrCb data is in binary format
FTM[2:0]	These three bits determine the video input data stream format and timing as listed in Table 2–9. The SCN bit (subaddress 90, bit 0) is also used in this decode.

Table 2–9. Input Format and Data Sampling

SCN	FTM[2:0]			INPUT FORMAT	SAMPLING TIME	INTERNAL ENCODER CLOCK
0	X	0	0	Reserved	Reserved	Reserved
0	X	0	1	YUV 4:2:2 on VP1 and VP2	Data is sampled at the rising edge of LLC qualified by CREF.	LLC
0	0	1	0	YUV 4:2:2 on VP1 port	Data is sampled at the rising edge of LLC	LLC
0	1	1	0	YUV 4:2:2 on VP2 port	Data is sampled at the rising edge of LLC	LLC
0	0	1	1	CCIR 656 on VP1 port	Data is sampled at the rising edge of LLC	LLC
0	1	1	1	CCIR 656 on VP2 port	Data is sampled at the rising edge of LLC	LLC
1	X	0	0	Reserved	Reserved	Reserved
1	X	0	1	YUV 4:2:2	Data is sampled at the rising edge of LLC	LLC
1	0	1	0	YUV 4:2:2 on VP1 port	Data is sampled at both edges of LLC	LLC
1	1	1	0	YUV 4:2:2 on VP2 port	Data is sampled at both edges of LLC	LLC
1	X	1	1	Reserved		

2.11.5 C_PHASE

Subaddress: 5A Default: 0x00

7	6	5	4	3	2	1	0
CPHS[7:0]							

Where:

CPHS[7:0] Phase of encoded video color subcarrier (including the color burst) relative to Hsync. The adjustable step is 360/256.

2.11.6 GAIN_U

Subaddress: 5B Default: 0x01

7	6	5	4	3	2	1	0
GU[7:0]							

Where:

GU[7:0] Gain control of Cb signal. The MSB, GU8, is located at subaddress 5D, bit 7. In the case of NTSC with a 7.5 IRE pedestal, WHITE – BLACK = 92.5 IRE Gain_U = 0x101. In the case of no pedestal (PAL/SECAM), WHITE – BLACK = 100 IRE. Gain_U = 0x115.

2.11.7 GAIN_V

Subaddress: 5C Default: 0x6B

7	6	5	4	3	2	1	0
GV[7:0]							

Where:

GV[7:0] Gain control of Cr signal. The MSB, GV8 is located at subaddress 5E, bit 7. In the case of NTSC with a 7.5 IRE pedestal, WHITE – BLACK = 92.5 IRE. Gain_V = 0x16B. In the case of no pedestal (PAL/SECAM), WHITE – BLACK = 100 IRE. Gain_V = 0x18C.

2.11.8 BLACK_LEVEL

Subaddress: 5D Default: 0xCC

7	6	5	4	3	2	1	0
GU8	BLACK[6:0]						

Where:

GU8 The most significant bit of the GAIN_U register. See the GAIN_U register for more information.
BLACK[6:0] Black level setting for NTSC = 0x4C and for PAL = 0x3C.

2.11.9 BLANK_LEVEL

Subaddress: 5E Default: 0xB8

7	6	5	4	3	2	1	0
GV8	BLANK[6:0]						

Where:

GV8 The most significant bit of the GAIN_V register. See the GAIN_V register for more information.

BLANK[6:0] Blank level setting for NTSC = 0x38 and for PAL = 0x3C.

2.11.10 GAIN_Y

Subaddress: 5F Default: 0x2E

7	6	5	4	3	2	1	0
GY[7-0]							

Where:

GY[7:0] Gain control of Y signal. The MSB, bit 8, is located at subaddress 60, bit 5.
 In the case of NTSC with a 7.5 IRE pedestal, WHITE – BLACK = 92.5 IRE.
 Gain_Y = 0x12E
 In the case of no pedestal (PAL/SECAM), WHITE – BLACK = 100 IRE.
 Gain_Y = 0x145

2.11.11 X_COLOR

Subaddress: 60 Default: 0x20

7	6	5	4	3	2	1	0
	XC	GY8			LCD[2-0]		

Cross color and chroma delay compensation register

Where:

XC Cross color reduction enable for composite video output. Cross color does not affect S-video output

0 Cross color reduction is disabled (default)

1 Cross color reduction is enabled

GY8 MSB of Gain_Y register.

LCD[2:0] These three bits can be used for chroma channel delay compensation during S-video mode. Table 2–10 shows the delay corresponding to the LCD[2:0] settings.

Table 2–10. Chroma Channel Delays

LCD[2:0]			DELAY ON CHROMA CHANNEL
0	0	0	0
0	0	1	0.5 pixel clock period
0	1	0	1 pixel clock period
0	1	1	1.5 pixel clock period
1	x	x	2 pixel clock period

2.11.12 M_CONTROL

Subaddress: 61 Default: 0x05

7	6	5	4	3	2	1	0
SDOWN	CDOWN	PALPHS		GLCE	CBW	PAL	FFRQ

Mode control register. This register provides various operating mode controls including DAC power management.

Where:

SDOWN	S-video DAC power down
0	Normal operation (default)
1	Power down mode
CDOWN	Composite video DAC power down
0	Normal operation (default)
1	Power down mode
PALPHS	PAL switch phase setting
0	PAL switch phase is nominal (default)
1	PAL switch phase is inverted compared to nominal
GLCE	Genlock control enable. See Table 2–20.
0	No genlock to the color subcarrier frequency (default)
1	Genlock-to-color subcarrier frequency is from the TVP5010
CBW	Chrominance encoding bandwidth enlarge enable
0	Bandwidth for chrominance encoding is enlarged
1	Standard bandwidth for chrominance encoding (default)
PAL	Phase alternation line encoding selection
0	Phase alternation line encoding disabled (default)
1	Phase alternation line encoding enabled
FFRQ	Field rate selection. Refer to Table 2–11 for programming information.
0	50 Hz
1	60 Hz (default)

2.11.13 BSTAMP

Subaddress: 62 Default: 0x38

7	6	5	4	3	2	1	0
SQP	BSTAP[6:0]						

Color burst amplitude

Where:

SQP	Square-pixel sampling rate. Refer to Table 2–11 for programming information.
0	CCIR601 sampling rate
1	Square-pixel sampling rate
BSTAP[6:0]	Setting of the amplitude of color burst. The value for NTSC = 0x38 and for PAL = 0x41.

The SQP and FFRQ bits control the total number of horizontal pixels displayed per scan line. In addition, these bits control the CCIR, NTSQ, and PASQ status pins as shown in Table 2–11.

Table 2–11. Total Horizontal Pixel Selection

MODE	SQP	FFRQ	CCIR	NTSQ	PASQ	NUMBER OF PIXELS PER LINE
CCIR601 PAL	0	0	high	low	low	864
CCIR601 NTSC	0	1	high	low	low	858
Square pixel PAL	1	0	low	low	high	944
Square pixel NTSC	1	1	low	high	low	780

2.11.14 S_CARR1, 2, 3, 4

Subaddress: 63, 64, 65, 66 Default: 0xF6, 0x7B, 0xF0, 0x21

7	6	5	4	3	2	1	0
FSC07	FSC06	FSC05	FSC04	FSC03	FSC02	FSC01	FSC00
FSC15	FSC14	FSC13	FSC12	FSC11	FSC10	FSC09	FSC08
FSC23	FSC22	FSC21	FSC20	FSC19	FSC18	FSC17	FSC16
FSC31	FSC30	FSC29	FSC28	FSC27	FSC26	FSC25	FSC24

Color subcarrier frequency registers

Where:

FSC[31:0] These four bytes of data are used to program the color subcarrier frequency. These four bytes are determined by the following formula.

$$S_carr = \text{ROUND}((Fsc/Fclock) \times 2^{32})$$

Table 2–12 lists some common values for S_CARR.

Table 2–12. S_CARR Values

STANDARD	PIXEL TYPE	SUBCARRIER FREQUENCY (fsc)	CLOCK (fclock)	S_CARR (dec)	S_CARR (hex)
M/NTSC	Rectangular	3.579545 MHz	27 MHz	569408543 (default)	21F07C1F
B, D, G, H, I, N/PAL	Rectangular	4.43361875 MHz	27 MHz	705268427	2A098ACB
N/PAL (combination N/PAL)	Rectangular	3.58205625 MHz	27 MHz	569807942	21F69446
M/PAL	Rectangular	3.5756083125 MHz	27 MHz	568782819	21E6EFE3
M/NTSC	Square	3.579545 MHz	24.5454 MHz	626349397	25555555
B, D, G, H, I, N/PAL	Square	4.43361875 MHz	29.5 MHz	645499916	26798C0C
N/PAL (combination N/PAL)	Square	3.58205625 MHz	29.5 MHz	521519134	1F15C01E
Combinational N	Square	3.5756083125 MHz	24.5454 MHz	625661101	254AD4AD

2.11.15 LINE21_O0

Subaddress: 67

7	6	5	4	3	2	1	0
L21O[7:0]							

Where:

L21O[7:0] Least significant byte of of closed caption data in odd field.
Initial value is undefined.

2.11.16 LINE21_O1

Subaddress: 68

7	6	5	4	3	2	1	0
L21O[15:8]							

Where:

L21O[15:8] Most significant byte of closed caption data in odd field.
Initial value is undefined.

2.11.17 LINE21_E0

Subaddress: 69

7	6	5	4	3	2	1	0
L21E[7:0]							

Where:

L21E[7:0] Least significant byte of extended service data in even field.

2.11.18 LINE21_E1

Subaddress: 6A

7	6	5	4	3	2	1	0
L21E[15:8]							

Where:

L21E[15:08] Most significant byte of extended service data in even field.

2.11.19 LN_SEL

Subaddress: 6B

7	6	5	4	3	2	1	0
SLINE[4:0]							

Where:

SLINE[4:0] Selects the line where closed caption or extended service data are encoded.

2.11.20 SYN_CTRL0

Subaddress: 6C Default: 0x00

7	6	5	4	3	2	1	0
RCV1A	RCV1B	HINSEL	ORCV1	PRCV1	CBLFV2	ORCV2	PRCV2

This register provides I/O control and the functional definition for the RCV1 and RCV2 pins.

Where:

RCV1A	This bit along with the RCV1B, SCN (bit 0, subaddress 90) define the signal type on pin RCV1. See Table 2–13 and Table 2–14.
RCV1B	This bit along with the RCV1A, SCN (bit 0, subaddress 90) define the signal type on pin RCV1. See Table 2–13 and Table 2–14.
HSINSEL	Horizontal synchronization input selection 0 RCV1 pin is the Hsync input 1 RCV2 pin is the Hsync input
ORCV1	Output RCV1 0 RCV1 is set as an input pin 1 RCV1 is set as an output pin
PRCV1	Polarity setting of RCV1 0 RCV1 is active high when it is set as an output, the rising edge is the active edge when it is set as an input. 1 RCV1 is active low when it is set as an output, the falling edge is the active edge when it is set as an input.
CBLFV2	Composite blanking output on RCV2. This bit combined with the SCN bit (bit 0, subaddress 90), CBLFV2 (bit 2, subaddress 6C), and HSINSEL bits (bit 5, subaddress 6C) define the signal type on RCV2. See Table 2–16 for programming information.
ORCV2	Output RCV2 0 RCV2 is set as an input pin 1 RCV2 is set as an output pin
PRCV2	Polarity setting of RCV2 0 RCV2 polarity is active high. The rising edge of RCV2 is the active edge. 1 RCV2 polarity is active low. The falling edge of RCV2 is the active edge.

The RCV1 pin configurations are listed in Table 2–13.

Table 2–13. RCV1 Pin Configurations

SCN	RCV1A	RCV1B	HSINSEL	RCV1 PIN	
				AS OUTPUT	AS INPUT
0	0	0	0	VSO	Unused
0	0	0	1	VSO	VSI
0	0	1	0	FSO	HSI and FSI
0	0	1	1	FSO	FSI
0	1	0	0	FSEQO	HSI and FSEQI
0	1	0	1	FSEQO	FSEQI
0	1	1	X	Reserved	Reserved
1	X	X	X	NFO	Reserved

The RCV1 symbols and signal descriptions are listed in Table 2–14.

Table 2–14. RCV1 Symbols and Signal Descriptions

SYMBOL	SIGNAL DESCRIPTION
VSO	Field synchronization output. Active once every field during vertical sync period. For NTSC, VS = 3 lines, for PAL, VS = 2.5 lines.
VSI	Vertical synchronization input. Retriggeres the vertical counter. The active edge in the first half of the scan line resets the vertical counter to VTRIG.
FSO	Frame synchronization output. Active in the odd field (first field). Inactive in the even field (second field).
FSEQO	Field sequence. For NTSC (bit 0, subaddress 61 set to 1), active only in the first field of every four fields. For PAL (bit 0, subaddress 61 reset to 0), active only in the first field of every eight fields.
NFO	New frame indicator output. In scan conversion mode (SCN set to 1), the active edge of this signal indicates to external logic to advance to the next frame.
HSO	Horizontal synchronization output.
HSI	Horizontal synchronization input. Retriggeres the horizontal counter.
FSI	Frame synchronization input. Retriggeres the vertical counter and resets the field to odd.
FSEQI	Field sequence input. Retriggeres the vertical counter and resets the field to the first of four fields for NTSC or the first of eight fields for PAL.

The RCV2 pin configurations are listed in Table 2–15.

Table 2–15. RCV2 Pin Configurations

SCN	CBLFV2	HSINSEL	RCV2 PIN	
			AS OUTPUT	AS INPUT
0	0	0	HSO	No function
0	0	1	HSO	HSI
0	1	0	CBNO	CBNI
0	1	1	CBNO	HSI and CBNI
1	X	X	NLO	Reserved

The RCV2 symbols and signal descriptions are listed in Table 2–16.

Table 2–16. RCV2 Symbols and Signal Descriptions

SYMBOL	SIGNAL DESCRIPTION
HSO	Horizontal synchronization output. As an output, RCV2 is asserted between BRCV and ERCV in every line including VBI.
HSI	As an input, RCV2 is used for horizontal synchronization. Retrigger the horizontal counter.
CBNO	As an output, RCV2 is asserted between BRCV and ERCV from line FAL to LAL excluding VBI.
CBNI	As an input, RCV2 is used for composite blanking.
NLO	Output only, RCV2 generates a 4 LLC clock wide new line indicator at the beginning of a line to indicate to the external logic to advance to the next line.

2.11.21 RCM_L21

Subaddress: 6D Default: 0x00

7	6	5	4	3	2	1	0
CRCM2	CBLFM2	ORCM2	PRCM2	RCM1A	RCM1B	L21ENA	L21ENB

Where:

- CRCM2 CREF modulation enable
 - 0 CREF modulation is disabled
 - 1 CREF modulation is enabled
 When RCM2 is programmed as an active video output (ORCM2 = 1), CREF modulation is enabled (CRCM2 = 1), and a 16-bit video input port is used, RCM2 is modulated by the internal CREF signal. The modulation is performed before polarity control.
- CBLFM2 See Table 2–18 for programming information.
- ORCM2 I/O setting of RCM2
 - 0 RCM2 is set as an input pin (default).
 - 1 RCM2 is set as an output pin.
- PRCM2 Polarity setting of RCM2
 - 0 RCM2 polarity is active high (default).
 - 1 RCM2 polarity is active low.
- RCM1A Determines which signal is output to pin RCM1. Refer to Table 2–17.
- RCM1B Determines which signal is output to pin RCM1. Refer to Table 2–17.
- L21ENA This bit controls the extended service closed caption encoding. See Table 2–19 for programming information.
- L21ENB This bit controls the closed caption encoding. See Table 2–19 for programming information.

Table 2–17. RCM1 Output Signals

RCM1A	RCM1B	PIN RCM1	DESCRIPTION
0	0	VS	Vertical synchronization (default)
0	1	FS	Frame synchronization
1	0	FSEQ	Field sequence. For NTSC, FSEQ is high in the first field of every four fields. For PAL, FSEQ is high in the first field of every eight fields.
1	1	N/A	Reserved

Table 2–18 shows the operating modes of pin RCM2 as defined by the SCN (bit 0, subaddress 98), CBLFM2 (bit 6, subaddress 6D), CBLFV2 (bit 2, subaddress 6C), and HSINSEL bits (bit 5, subaddress 6C).

Table 2–18. RCM2 Pin Configurations

SCN	CBLFM2	CBLFV2	HSINSEL	RCM2 PIN		SIGNAL DESCRIPTION
				AS OUTPUT	AS INPUT	
0	0	X	X	HSO	No function	As an output, RCM2 is asserted between BMRQ and EMRQ in every line including VBI (sub-address 71–73)
0	1	0	0	CBNO	No function	As an output, RCM2 is asserted between BMRQ and EMRQ in every line excluding VBI.
0	1	0	1	CBNO	CBNI	As an input, RCM2 is used for composite blanking. As an output, RCM2 is asserted between BMRQ and EMRQ in every line excluding VBI.
0	1	1	X	CBNO	No function	As an output, RCM2 is asserted between BMRQ and EMRQ in every line excluding VBI.
1	X	X	X	RQO	Reserved	As an output only. RCM2 is used as request for pixels. When asserted, this signal sources the pixel on the bus at the clock edge and informs external logic to output next pixel.

Table 2–19. Encoding Setting

L21ENA	L21ENB	LINE 21 ENCODING MODE
0	0	Line 21 encoding off
0	1	Enables encoding in first field (odd field)
1	0	Enables encoding in second field (even field)
1	1	Enables encoding both fields

2.11.22 HTRIGGER0

Subaddress: 6E Default: 0xE0

7	6	5	4	3	2	1	0
HTRIG[7:0]							

Where:

HTRIG[7:0] Least significant bit of horizontal trigger phase setting for RCV1 and RCV2 as inputs. HTRIG is expressed in half-pixels or clk2x periods.

2.11.23 HTRIGGER1

Subaddress: 6F Default: 0x8C

7	6	5	4	3	2	1	0
						HTRIG[10:8]	

Where:

HTRIG[10:8] Most significant bit of horizontal trigger phase setting for RCV1 and RCV2 as inputs. HTRIG is expressed in half-pixels or clk2x periods.

2.11.24 VTRIGGER

Subaddress: 70 Default: 0xC0

7	6	5	4	3	2	1	0
PRESA	PRESB	SBLANK	VTRIG[4:0]				

Where:

PRESA Phase reset A. Used as shown in Table 2–20.
 PRESB Phase reset B. Used as shown in Table 2–20. These two bits decide how frequently the color subcarrier is reset to CPHS (subaddress 5A). GLCE is bit 3, subaddress 61.
 SBLANK Vertical blanking setting
 0 Vertical blanking is defined by the settings of the FAL and LAL registers
 1 Vertical blanking is forced automatically during field synchronization and equalization.

VTRIG[4:0] Vertical trigger reference for pin RCV1. These bits specify where on a field of sixteen lines the RCV1 pin is triggered. The VTRIG field is expressed in units of a half line.

Table 2–20. Phase Reset Modes

GLCE	PRESA	PRESB	PHASE RESET MODE
0	0	0	No reset
0	0	1	Reset every two lines
0	1	0	Reset every eight fields
0	1	1	Reset every four fields
1	X	X	Reset by reset bit on GLCI pin

2.11.25 BMRQ

Subaddress: 71

7	6	5	4	3	2	1	0
BMRQ[7:0]							

Beginning of master request.

Where:

BMRQ[7:0] These bits define the starting pixel position on a horizontal display line where active video will be displayed. The upper three bits, BMRQ[10:8], reside in register BEMRQ, subaddress 73. These settings shape the RCM2 pin output.

2.11.26 EMRQ

Subaddress: 72

7	6	5	4	3	2	1	0
EMRQ[7:0]							

End of master request.

Where:

EMRQ[7:0] These bits define the ending pixel position on a horizontal display line where active video will end. The upper three bits, EMRQ[10:8], reside in register BEMRQ, subaddress 73. These settings shape the RCM2 pin output.

2.11.27 BEMRQ

Subaddress: 73

15	14	13	12	11	10	9	8
EMRQ[10:8]				BMRQ[10:8]			

Overflow register for master request.

Where:

EMRQ[10:8] Upper three bits of register EMRQ. See EMRQ register definition

BMRQ[10:8] Upper three bits of register BMRQ. See BMRQ register definition

2.11.28 BRCV

Subaddress: 77

7	6	5	4	3	2	1	0
BRCV[7:0]							

Beginning of raster control, RCV2, out.

Where:

BRCV[7:0] These bits along with the CBLFV2 bit in the SYN_CTRL0 register defines the beginning of the active output at pin RCV2. The upper three bits of this register are in register BERCV, subaddress 79.

2.11.29 ERCV

Subaddress: 78

7	6	5	4	3	2	1	0
ERCV[7:0]							

End of raster control, RCV2, out.

Where:

ERCV[7:0] These bits along with the CBLFV2 bit in the SYN_CTRL0 register defines the ending of the active output at pin RCV2. The upper three bits of this register are in register BERCV, subaddress 79.

2.11.30 BERCV

Subaddress: 79

15	14	13	12	11	10	9	8
ERCV[10:8]				BRCV[10:8]			

Overflow register for BRCV and ERCV fields.

Where:

ERCV[10:8] These bits along with the CBLFV2 bit in the SYN_CTRL0 register define the ending of the active output at pin RCV2. The lower eight bits of this register are in register ERCV, subaddress 78.

BRCV[10:8] These bits along with the CBLFV2 bit in the SYN_CTRL0 register define the beginning of the active output at pin RCV2. The lower eight bits of this register are in register BRCV, subaddress 77.

2.11.31 FLEN

Subaddress: 7A Default: 0x0C

7	6	5	4	3	2	1	0
FLEN[7:0]							

Field length

Where:

FLEN[7:0] These bits define the number of half lines in each field. The upper two bits of this register are located in the FLAL register.

Length of field = (FLEN + 1) half lines

2.11.32 FAL

Subaddress: 7B Default: 0x12

7	6	5	4	3	2	1	0
FAL[7:0]							

First active line of a field

Where:

FAL[7:0] These bits define the first active line of a field. The MSB is located in the FLAL register.

2.11.33 LAL

Subaddress: 7C Default:0x03

7	6	5	4	3	2	1	0
LAL[7:0]							

Last active line of a field.

Where:

LAL[7:0] These bits define last active line of a field. The MSB is located in the register FLAL.

2.11.34 FLAL

Subaddress: 7D Default: 0x22

7	6	5	4	3	2	1	0
		LAL[8]	FAL[8]			FLEN[9:8]	

First and last active line of a field. Overflow bits from FAL and LAL registers.

Where:

LAL[8] These bits define the last active line of a field. The LSB is located in the LAL register.

FAL[8] These bits define the first active line of a field. The LSB is located in the FAL register.

FLEN[9:8] These bits define the number of half lines in each field. The lower eight bits of this register are located in the FLEN register.

2.11.35 SYN_CTRL1

Subaddress: 7E Default: 0x18

7	6	5	4	3	2	1	0
	ESAV	IGNP	FREE	BLNKS	AVM[1:0]		FID

Where:

ESAV Enable for the detection of F and V bits only on EAV in CCIR656 input mode

0 Detection of F and V bits on both EAV and SAV

1 Detection of F and V bits only on EAV

IGNP Ignore protection bits in CCIR656 input mode

0 Protection bits not ignored

1 Protection bits ignored

FREE Free running

0 Free running disabled

1 Free running enabled. All external signals are ignored. Internal timing signals are used.

BLNKS Blank shaping

0 Blank shaping disabled

1 Blank shaping enabled

AVM[1:0] Active video mode. See Table 2–21.

Table 2–21. Active Video Modes

AVM[1]	AVM[0]	ACTIVE VIDEO MODE
0	0	Active video gating signal is the combination of: <ol style="list-style-type: none"> 1. Default horizontal gating 2. Programmable vertical gating defined by FAL, LAL, and SBLANK. 3. External gating
0	1	Active video gating signal is the combination of: <ol style="list-style-type: none"> 1. Default horizontal gating 2. Programmable vertical gating defined by FAL, LAL, and SBLANK.
1	0	Active video gating signal is generated externally.
1	1	Active video gating signal is the combination of: <ol style="list-style-type: none"> 1. Programmable internal horizontal gating defined by BRCV and ERCV. 2. Programmable vertical gating defined by FAL, LAL, and SBLANK.

2.11.36 SCM

Subaddress: 90 Default: 0x00

7	6	5	4	3	2	1	0
		SWPF	HSC[1:0]		VSC[1:0]		SCN

Scan conversion register. This register provides control bits for overscan compensation.

Where:

- SWPF SwapField. This bit must be set to 0 for normal applications
 - 0 Fields are not swapped
 - 1 Fields are swapped
- HSC[1:0] Horizontal scaling and interpolation mode
 - 00 Horizontal scaling disabled
 - 01 Nearest neighbor
 - 10 Interpolation filter coefficients are according to inverse square law
 - 11 Reserved
- VSC[1:0] Vertical scaling and interpolation filter mode
 - 00 Vertical scaling disabled
 - 01 Nearest neighbor
 - 10 Interpolation filter coefficients = (1/4 1/2 1/4)
 - 11 Interpolation filter coefficients = (1/8 3/4 1/8)
- SCN Scan conversion enable
 - 0 Noninterlaced-to-interlaced scan conversion disabled
 - 1 Noninterlaced-to-interlaced scan conversion enabled

2.11.37 SLPF

Subaddress: 91

7	6	5	4	3	2	1	0
SLPF[7:0]							

Source scan lines per frame before scaling.

Where:

- SLPF[7:0] Number of lines per frame in the source image before scaling. The most significant two bits of this field are located in the SLPH register.

2.11.38 SPPL

Subaddress: 92

7	6	5	4	3	2	1	0
SPPL[7:0]							

Source pixels per scan line before scaling.

Where:

SPPL[7:0] Number of pixels per line in the source image before scaling. SPPL0 is hardwired to 0. The most significant two bits of this field are located in the SLPH register.

2.11.39 SLPH

Subaddress: 93

7	6	5	4	3	2	1	0
SPPL[9:8]				SLPF[9:8]			

Where:

SPPL[9:8] Number of pixels per scan line in the source image before scaling. The LSB of this field is located in the SPPL register.

SLPF[9:8] Number of lines per frame in the source image before scaling. The LSB of this field is located in the SLPF register.

2.11.40 DLPF

Subaddress: 94

7	6	5	4	3	2	1	0
DLPF[7:0]							

Destination lines per frame after scaling.

Where:

DLPF[7:0] Number of lines per frame in the destination image after scaling. The two most significant bits of this field are located in the DLPH register.

2.11.41 DPPL

Subaddress: 95

7	6	5	4	3	2	1	0
DPPL[7:0]							

Destination pixels per scan line.

Where:

DPPL[7:0] Number of lines per frame in the destination image after scaling. DPPL0 is hardwired to 0. The two most significant bits of this field are located in the DLPH register.

2.11.42 DLPH

Subaddress: 96

7	6	5	4	3	2	1	0
DPPL[9:8]				DLPF[9:8]			

Where:

DPPL[9:8] Number of pixels per scan line in the destination image after scaling. The LSB of this field are located in the DPPL register.

DLPF[9:8] Number of lines per frame in the destination image after scaling. The LSB of this field is located in the DLPF register.

2.11.43 VDTAL

Subaddress: 97

7	6	5	4	3	2	1	0
VDTA[7:0]							

Where:

VDTA[7:0] Vertical over-scan compensation ratio. The MSB of this field is located in the VDTAH register. The value of VDTA is calculated as follows:

$$VDTA = \text{ROUND}(((\text{SLPF}/\text{DLPF})-1)\times 2^{16})$$

where SLPF = Number of scan lines per frame in the source image before scaling,
DLPF = Number of lines per frame in the destination image after scaling.

2.11.44 VDTAH

Subaddress: 98

7	6	5	4	3	2	1	0
VDTA[15:8]							

Where:

VDTA[15:8] Vertical over-scan compensation ratio. The LSB of this field is located in the VDTAL register. Refer to the description of VDTAL for more information.

2.11.45 HDTAL

Subaddress: 99

7	6	5	4	3	2	1	0
HDTA[7:0]							

Where:

HDTA[7:0] Horizontal over-scan compensation ratio. The MSB of this field is located in the HDTAH register. The value of HDTA is calculated as follows:

$$HDTA = \text{ROUND}(((\text{SPPL}/\text{DPPL})-1)\times 2^{16})$$

where SPPL = Number of pixels per line in the source image before scaling,
DPPL = Number of pixels per line in the destination image after scaling.

2.11.46 HDTAH

Subaddress: 9A

7	6	5	4	3	2	1	0
HDTA[15:8]							

Where:

HDTA[15:8] Horizontal over-scan compensation ratio. The LSB of this field is located in the HDTAL register. Refer to the description of HDTAL for more information.

2.11.47 VOFS

Subaddress: 9B

7	6	5	4	3	2	1	0
VOFS[7:0]							

Vertical offset

Where:

VOFS[7:0] Vertical offset of the scaled image on the screen in lines from beginning of the field. This register is used with HOFSS register to position the scaled image on the screen. Vertical offset is given in units of two scan lines in a field or four scan lines in a frame.

2.11.48 HOFSS

Subaddress: 9C

7	6	5	4	3	2	1	0
HOFSS[7:0]							

Horizontal offset

Where:

HOFSS[7:0] Horizontal offset of the scaled image on the screen in pixels from the beginning of the scan line. Used with VOFS register to position the scaled image on the screen. Horizontal offset is given in units of four pixels.

2.11.49 NLR

Subaddress: 9D

7	6	5	4	3	2	1	0
NLR[7:0]							

New line request

Where:

NLR[7:0] The minimum number of LLC clock delays between the trailing edge of NEWLINE and the leading edge of REQUEST. The value must be sufficiently large to give the graphics controller enough time to supply pixel data when REQUEST is asserted.

2.11.50 TEST1, TEST2, TEST3

Subaddress: 9E, 9F, A0

These three register are reserved for chip test purposes only. No applications should access them.

3 Electrical Characteristics

3.1 Absolute Maximum Ratings Over Operating Free-Air Temperature Range (Unless Otherwise Noted)[†]

Digital power supply voltage range, DV_{DD}	−0.5 V to 7 V
Analog power supply voltage range, AV_{DD}	−0.5 V to 7 V
Digital input voltage range, V_I	−0.5 V to 5.5 V
Digital output voltage range, V_O	0 V to 5.5 V
Operating free-air temperature range, T_A	0°C to 70°C
Storage temperature range, T_{stg}	−65°C to 150°C
Maximum total power dissipation, P_D	2 W

[†] Stresses beyond those listed under “absolute maximum ratings” may cause permanent damage to the device. These are stress ratings only and functional operation of the device at these or any other conditions beyond those indicated under “recommended operating conditions” is not implied. Exposure to absolute-maximum-rated conditions for extended periods may affect device reliability.

3.2 Recommended Operating Conditions

	MIN	NOM	MAX	UNIT
Digital supply voltage, DV_{DD}	4.75	5	5.25	V
Analog supply voltage, AV_{DD}	4.75	5	5.25	V
Digital low-level input voltage, V_{IL}	0		0.8	V
Digital high-level input voltage, V_{IH}	2.4		V_{DD}	V
Digital supply current, I_{DD}			180	mA
Analog supply current, I_{DD}			125	mA
Reference voltage, V_{REF}	1.23	1.25	1.29	V
External load resistor, double termination, R_L		37.5		Ω
Output load capacitance, DAC, C_L		25		pF
Operating free-air temperature, T_A	0		70	°C

3.3 DC Electrical Characteristics, $T_A = 25^\circ\text{C}$, $DV_{DD} = AV_{DD} = 5\text{ V}$

PARAMETER	TEST CONDITIONS	MIN	TYP	MAX	UNIT
V_{OL} Low-level output voltage		0		0.4	V
V_{OH} High-level output voltage		2.4		V_{DD}	V
I_{lkg} Input leakage current				5 [†]	μA
C_i Input capacitance	$f = 1\text{ MHz}$			10	pF
Resolution (each DAC)			10		bit
INL Integral nonlinearity	$R_L = 37.5\ \Omega$			± 2	LSB
DNL Differential nonlinearity	$R_L = 37.5\ \Omega$			± 1	LSB
I_o Output current (each DAC)	$R_L = 37.5\ \Omega$		34.8	38	mA
Z_o Output impedance			20		k Ω
C_o Output capacitance	$f = 1\text{ MHz}$			5	pF
F_{out} Full scale DAC output			182.68		IRE

[†] Maximum leakage current for XTAL1 and XTAL2 pins is 50 μA .

3.4 AC Electrical Characteristics, $T_A = 25^\circ\text{C}$, $DV_{DD} = AV_{DD} = 5\text{ V}$

PARAMETER		TEST CONDITIONS	MIN	TYP	MAX	UNIT
DP	Differential phase, video	NTSC/PAL		2		degrees
DG	Differential gain, video			2		%
SNR	Signal-to-noise ratio, video			70†		dB
	Luma nonlinearity			1.2		%
	Subcarrier tolerance			0.0028		Hz
	Analog output skew (Y to C)			1.2		ns
	Y/C gain			97		%

† SNR measured as specified in EIA/TIA-250-C.

3.5 Timing Requirements

		TEST CONDITIONS	MIN	NOM	MAX	UNIT
f _{I2C}	Clock frequency, I ² C interface	2 k Ω pull-up resistor, 400 pF			400	kHz
	Duty cycle, I ² C interface			50		%
f _{LLC}	Clock frequency, pixel clock	CCIR 601		27		MHz
		NTSC square pixel		24.5454		
		PAL square pixel		29.5		
t _{su}	Input data setup time, digital interface	f _{LLC} = 30 MHz	5			ns
t _{hd}	Input data hold time, digital interface	f _{LLC} = 30 MHz	2			ns
t _{pd}	Output delay time, digital interface	f _{LLC} = 30 MHz			18	ns
t _{reset}	Synchronize reset time		200			ns
t _(NLR)	New line request, register 0x9D					
t _{SPPL}	Register 0x92					

3.6 Demand Mode Timing

		TEST CONDITIONS	MIN	NOM	MAX	UNIT
t _{d(TVIHV2L)}	Delay time, RCV1 high to RCV2 low			2		CLKX2 Periods
t _{w(TV2PW)}	Pulse duration, RCV2			4		
t _{d(TV2HVIL)}	Delay time, RCV2 high to RCV1 low			2		

3.7 Switching Characteristics

		TEST CONDITIONS	MIN	NOM	MAX	UNIT
t _r	Rise time, pixel clock	C _L = 50 pF			4	ns
t _f	Fall time, pixel clock	C _L = 50 pF			4	ns
	Duty cycle, pixel clock			50		%

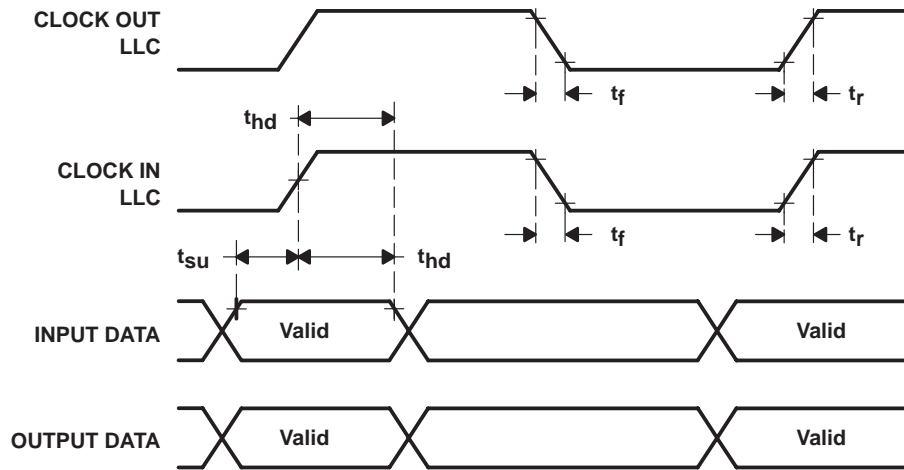

Figure 3-1. Data Setup and Hold Timing

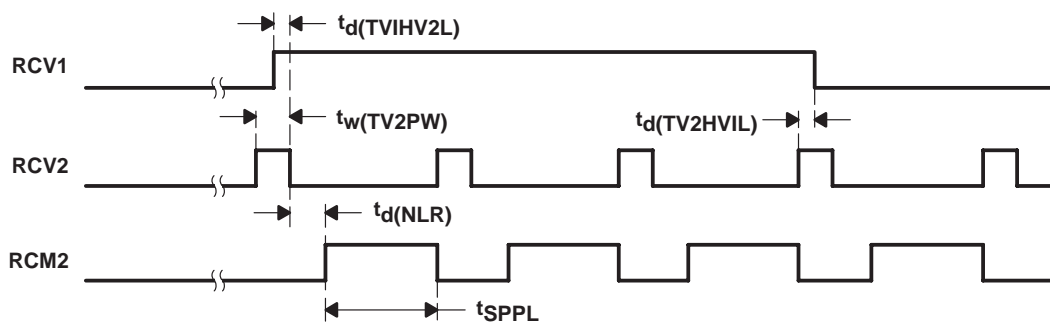

Figure 3-2. Demand Mode Timing

Appendix A

Example Register Settings

Table A-1 lists the register settings for various NTSC and PAL applications. The following modes are represented in the table. All of the modes except NSDM employ genlock mode. The genlock mode is described in more detail in Section 3.

- N601 NTSC standard with CCIR-601 compliant pixels and slave mode configuration
- NSQP NTSC standard with square pixels and slave mode configuration
- P601 PAL standard with CCIR-601 compliant pixels and slave mode configuration
- PSQP PAL standard with square pixels and slave mode configuration
- NSDM NTSC standard with square pixels and demand mode configuration

Table A-1. Example Register Settings

REGISTER	ADDRESS	N601	NSQP	P601	PSQP	NSDM
F_CONTROL	3A	0E	0E	0E	0E	0E
CPHS	5A	00	00	00	00	00
GAIN_U	5B	01	01	10	10	01
GAIN_V	5C	6B	6B	80	80	6B
BLACKLVL	5D	CC	CC	BE	BE	CC
BLANKLVL	5E	B8	B8	BE	BE	B8
GAIN_Y	5F	2E	2E	3F	3F	2E
XCOLOR	60	60	60	60	60	60
M_CTRL	61	05	05	06	06	05
BSTAMP	62	38	B8	3F	BF	B8
S_CARR0	63	1F	55	CB	0C	55
S_CARR1	64	7C	55	8A	8C	55
S_CARR2	65	F0	55	09	79	55
S_CARR3	66	21	25	2A	26	25
LINE21O0	67	94	94	94	94	94
LINE21O1	68	26	26	26	26	26
LINE21E0	69	80	80	80	80	80
LINE21E1	6A	80	80	80	80	80
LN_SEL	6B	11	11	11	11	11
SYNCTRL0	6C	12	12	12	12	12
RCML21	6D	21	21	21	21	21
HTRIG0	6E	00	00	00	00	00
HTRIG1	6F	00	00	00	00	00
VTRIG	70	C0	C0	80	80	C0
BMRQ	71	82	74	8C	9A	74

Table A-1. Example Register Settings (Continued)

REGISTER	ADDRESS	N601	NSQP	P601	PSQP	NSDM
EMRQ	72	46	F8	4C	9A	F8
BEMRQ	73	30	20	30	30	20
BRCV	77	82	74	8C	9A	74
ERCV	78	46	F8	4C	9A	F8
BERCV	79	30	20	30	30	20
FLEN	7A	0C	0C	70	70	0C
FAL	7B	17	17	17	17	17
LAL	7C	02	02	34	34	02
FLAL	7D	22	22	22	22	22
SYN_CTRL1	7E	0A	0A	0A	0A	0A
SCM	90	00	00	00	00	55
SLPFL	91	00	00	00	00	E0
SPPLL	92	00	00	00	00	80
SLPH	93	00	00	00	00	21
DLPFL	94	00	00	00	00	AC
DPPLL	95	00	00	00	00	3A
DLPH	96	00	00	00	00	21
VDTAL	97	00	00	00	00	1A
VDTAH	98	00	00	00	00	1F
HDTAL	99	00	00	00	00	70
HDTAH	9A	00	00	00	00	1F
VOFS	9B	00	00	00	00	0F
HOFS	9C	00	00	00	00	09
NLR	9D	00	00	00	00	1D

Appendix B

Mechanical Data

PFP (S-PQFP-G80)

PowerPAD™ PLASTIC QUAD FLATPACK

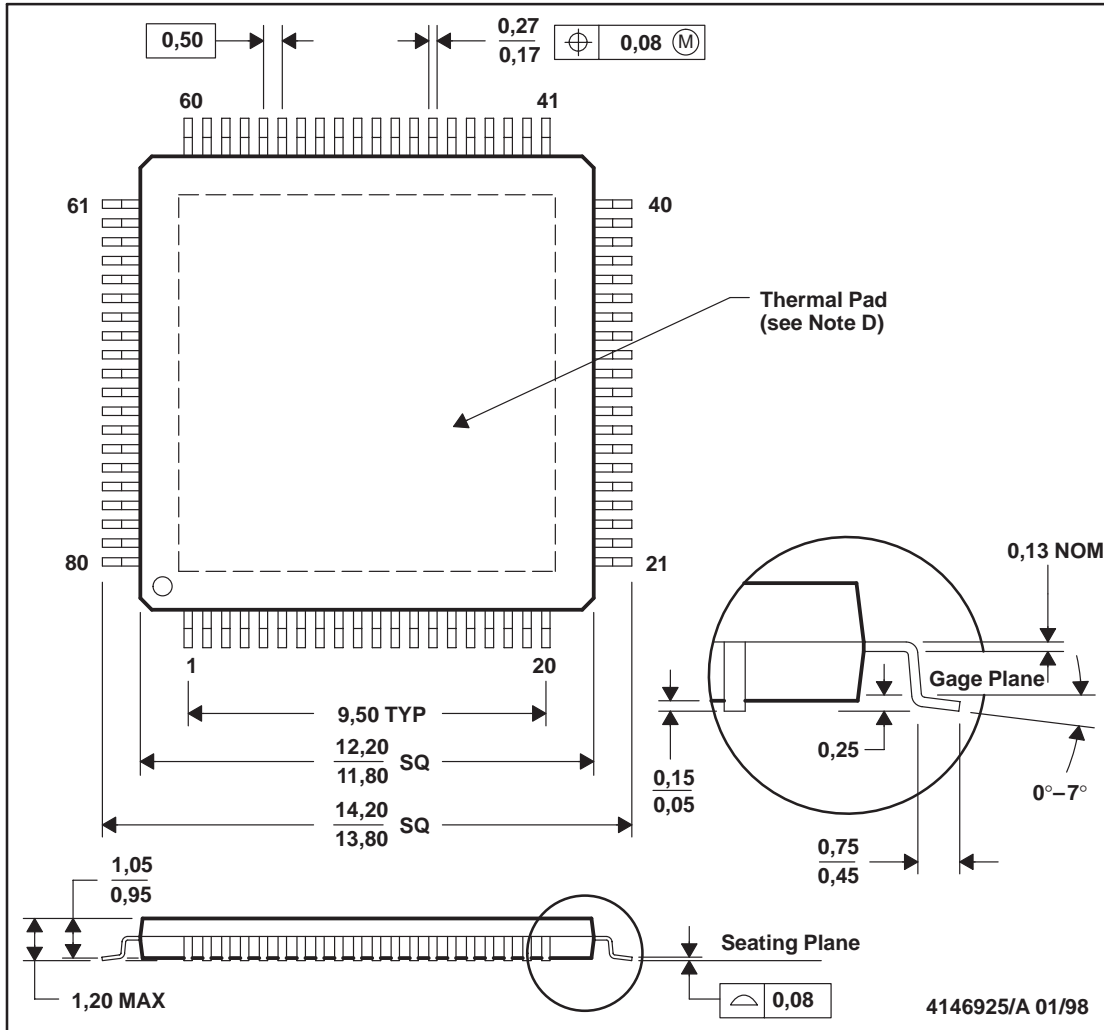

- NOTES:
- A. All linear dimensions are in millimeters.
 - B. This drawing is subject to change without notice.
 - C. Body dimensions include mold flash or protrusions.
 - D. The package thermal performance may be enhanced by bonding the thermal pad to an external thermal plane. This pad is electrically and thermally connected to the backside of the die and possibly selected leads.
 - E. Falls within JEDEC MS-026

PowerPAD is a trademark of Texas Instruments Incorporated.

IMPORTANT NOTICE

Texas Instruments and its subsidiaries (TI) reserve the right to make changes to their products or to discontinue any product or service without notice, and advise customers to obtain the latest version of relevant information to verify, before placing orders, that information being relied on is current and complete. All products are sold subject to the terms and conditions of sale supplied at the time of order acknowledgement, including those pertaining to warranty, patent infringement, and limitation of liability.

TI warrants performance of its semiconductor products to the specifications applicable at the time of sale in accordance with TI's standard warranty. Testing and other quality control techniques are utilized to the extent TI deems necessary to support this warranty. Specific testing of all parameters of each device is not necessarily performed, except those mandated by government requirements.

CERTAIN APPLICATIONS USING SEMICONDUCTOR PRODUCTS MAY INVOLVE POTENTIAL RISKS OF DEATH, PERSONAL INJURY, OR SEVERE PROPERTY OR ENVIRONMENTAL DAMAGE ("CRITICAL APPLICATIONS"). TI SEMICONDUCTOR PRODUCTS ARE NOT DESIGNED, AUTHORIZED, OR WARRANTED TO BE SUITABLE FOR USE IN LIFE-SUPPORT DEVICES OR SYSTEMS OR OTHER CRITICAL APPLICATIONS. INCLUSION OF TI PRODUCTS IN SUCH APPLICATIONS IS UNDERSTOOD TO BE FULLY AT THE CUSTOMER'S RISK.

In order to minimize risks associated with the customer's applications, adequate design and operating safeguards must be provided by the customer to minimize inherent or procedural hazards.

TI assumes no liability for applications assistance or customer product design. TI does not warrant or represent that any license, either express or implied, is granted under any patent right, copyright, mask work right, or other intellectual property right of TI covering or relating to any combination, machine, or process in which such semiconductor products or services might be or are used. TI's publication of information regarding any third party's products or services does not constitute TI's approval, warranty or endorsement thereof.