

## 阅读申明

- 1.本站收集的数据手册和产品资料都来自互联网，版权归原作者所有。如读者和版权方有任何异议请及时告之，我们将妥善解决。
- 2.本站提供的中文数据手册是英文数据手册的中文翻译，其目的是协助用户阅读，该译文无法自动跟随原稿更新，同时也可能存在翻译上的不当。建议读者以英文原稿为参考以便获得更精准的信息。
- 3.本站提供的产品资料，来自厂商的技术支持或者使用者的心得体会等，其内容可能存在描述上的差异，建议读者做出适当判断。
- 4.如需与我们联系，请发邮件到marketing@iczoom.com，主题请标有“数据手册”字样。

## Read Statement

1. The datasheets and other product information on the site are all from network reference or other public materials, and the copyright belongs to the original author and original published source. If readers and copyright owners have any objections, please contact us and we will deal with it in a timely manner.
2. The Chinese datasheets provided on the website is a Chinese translation of the English datasheets. Its purpose is for reader's learning exchange only and do not involve commercial purposes. The translation cannot be automatically updated with the original manuscript, and there may also be improper translations. Readers are advised to use the English manuscript as a reference for more accurate information.
3. All product information provided on the website refer to solutions from manufacturers' technical support or users the contents may have differences in description, and readers are advised to take the original article as the standard.
4. If you have any questions, please contact us at marketing@iczoom.com and mark the subject with "Datasheets" .

Marking Layout

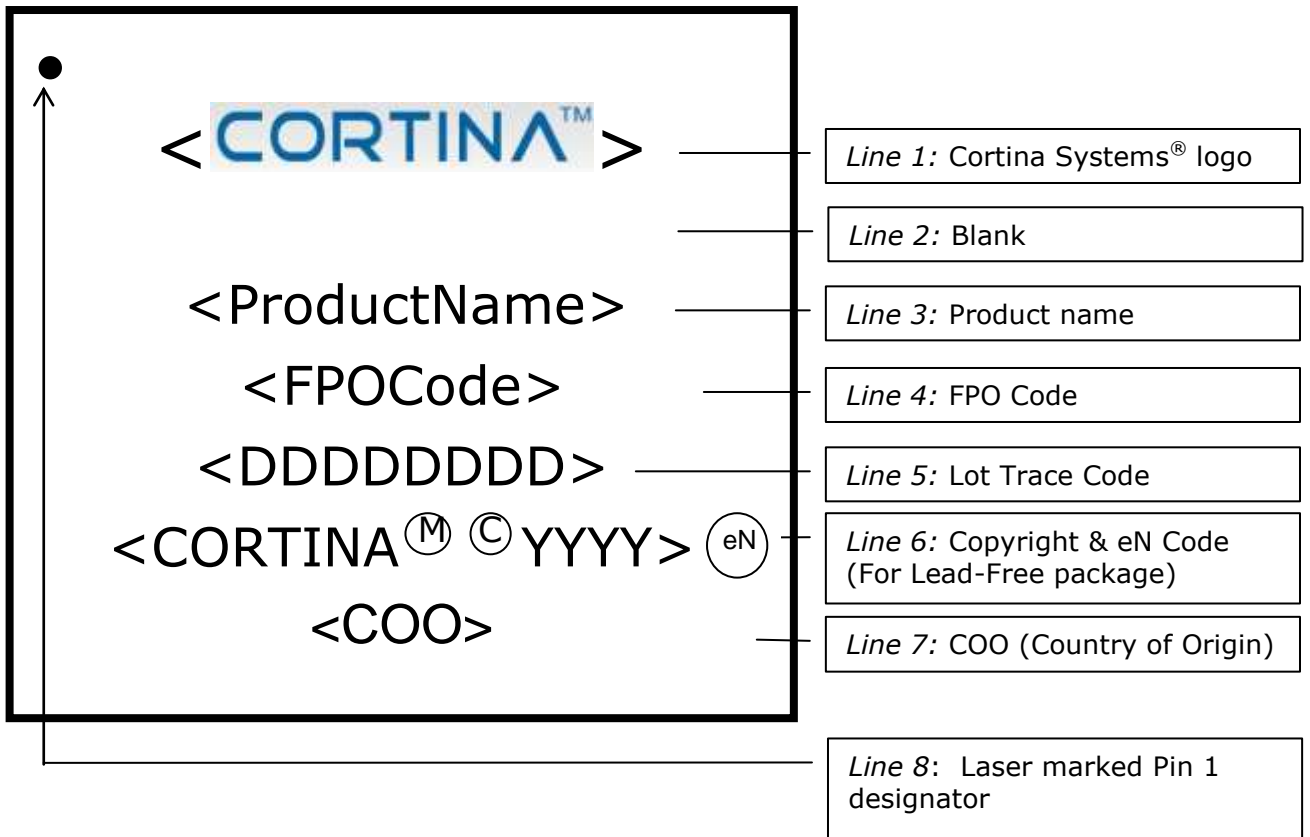

Photograph of Marked Device



Marking Layout Description

Line #	Content	Fixed or Dynamic	Alignment	Font
1	Cortina Systems® logo	Fixed	Centered	NA
2	Reserved for Customer / Marketing	NA	NA	NA
3	Product Name	Fixed	Centered	Arial
4	FPO Code	Dynamic	Centered	Arial
5	Lot Trace Code	Dynamic	Centered	Arial
6	Copyright	Fixed	Left	Arial
7	COO (Country of Origin) & en (e1) as required	Fixed	Centered	Arial
7	Pin 1 Location marked by designator	Fixed	Left	NA

Product Naming Decoder

- RP** RP Stands for RoHS compliance level and Package Designator (FCBGA)
- RPCS** CS stands for the Product Prefix
- RPCS1999** Product number is a 3-5 digit alphanumeric
- RPCS1999C** Temperature indicator (commercial, extended)
- RPCS1999C A0** Product revision, xn=2 Alphanumeric character

\* Device name may be truncated or alphanumeric characters left out intentionally on actual part marking due to lack of space and the need for legibility.

Product Order Number

**RPCS1999C.A0-998866** The complete Cortina Systems ordering code includes this numeric 6 digit number. The MM# identifies the packing media (Tube, Tray, and Tape & Reel) from identical devices. Product revision changes are assigned new MM#. The MM# is not marked on the physical component but it appears on MBB, box and packing labels, packing slips, shipping documents, and invoices.

FPO Number & Date Code

- BYWWT00A** Fixed header character for test subcontractor / location
- BYWWT00A** Last digit of manufacturing year, Ex: Year 2009 = 9
- BYWWT00A** Cortina workweek, first week of January = 01
- BYWWT00A** Assembly house and location code
- BYWWT00A** Sequential number that resets when WW is incremented:  
Refers to both sub-lots and wafer lots.

Lot Trace Code Cortina Internal use.

<b>Author</b>	<b>Revision Content</b>	<b>Rev No.</b>	<b>Date</b>
SY Fong	Initial Release	1.0	18 February 2009

**INFORMATION IN THIS DOCUMENT IS PROVIDED IN CONNECTION WITH CORTINA SYSTEMS® PRODUCTS. NO LICENSE, EXPRESS OR IMPLIED, BY ESTOPPEL OR OTHERWISE, TO ANY INTELLECTUAL PROPERTY RIGHTS IS GRANTED BY THIS DOCUMENT. EXCEPT AS PROVIDED IN CORTINA'S TERMS AND CONDITIONS OF SALE OF SUCH PRODUCTS, CORTINA ASSUMES NO LIABILITY WHATSOEVER, AND CORTINA DISCLAIMS ANY EXPRESS OR IMPLIED WARRANTY RELATING TO THE SALE AND/OR USE OF CORTINA PRODUCTS, INCLUDING LIABILITY OR WARRANTIES RELATING TO FITNESS FOR A PARTICULAR PURPOSE, MERCHANTABILITY OR INFRINGEMENT OF ANY PATENT, COPYRIGHT OR OTHER INTELLECTUAL PROPERTY RIGHT.**

Cortina products are not intended for use in medical, life saving, life sustaining, critical control or safety systems, or in nuclear facility applications.

CORTINA SYSTEMS®, CORTINA™, and the Cortina Earth Logo are trademarks or registered trademarks of Cortina Systems, Inc. or its subsidiaries in the US and other countries. Any other product and company names are the trademarks of their respective owners.

Copyright © 2009 Cortina Systems, Inc. All rights reserved.