

阅读申明

- 1.本站收集的数据手册和产品资料都来自互联网，版权归原作者所有。如读者和版权方有任何异议请及时告之，我们将妥善解决。
- 2.本站提供的中文数据手册是英文数据手册的中文翻译，其目的是协助用户阅读，该译文无法自动跟随原稿更新，同时也可能存在翻译上的不当。建议读者以英文原稿为参考以便获得更精准的信息。
- 3.本站提供的产品资料，来自厂商的技术支持或者使用者的心得体会等，其内容可能存在描述上的差异，建议读者做出适当判断。
- 4.如需与我们联系，请发邮件到marketing@iczoom.com，主题请标有“数据手册”字样。

Read Statement

1. The datasheets and other product information on the site are all from network reference or other public materials, and the copyright belongs to the original author and original published source. If readers and copyright owners have any objections, please contact us and we will deal with it in a timely manner.
2. The Chinese datasheets provided on the website is a Chinese translation of the English datasheets. Its purpose is for reader's learning exchange only and do not involve commercial purposes. The translation cannot be automatically updated with the original manuscript, and there may also be improper translations. Readers are advised to use the English manuscript as a reference for more accurate information.
3. All product information provided on the website refer to solutions from manufacturers' technical support or users the contents may have differences in description, and readers are advised to take the original article as the standard.
4. If you have any questions, please contact us at marketing@iczoom.com and mark the subject with "Datasheets" .

Speech network

BA6566 / BA6566F / BA6566FP

The BA6566, BA6566F, and BA6566FP are speech network ICs which possess the basic functions required for handset communications. In addition to amplifying signals from a transmitter and sending them to a telephone line, they amplify only reception signals from a telephone line and drive the receiver. They also compensate for fluctuation in the volume at which signals are transmitted and received, caused by the length of the telephone line (AGC).

● Applications

Telephones and telephone equipment

● Features

- 1) Can accommodate both dynamic and piezoelectric receivers, simply by changing the circuit constant for a wide dynamic reception range.
- 2) Automatic gain control (AGC) is used, based on the transmission and reception telephone line current, for easier compliance with communications standards.
- 3) Erroneous operation caused by high-frequency electrical wave interference is minimized.
- 4) An HSOP package is used, eliminating the need for an attached transistor to dissipate heat. This means that a common circuit can be shared when a DIP package is used (BA6566FP).

● Block diagram

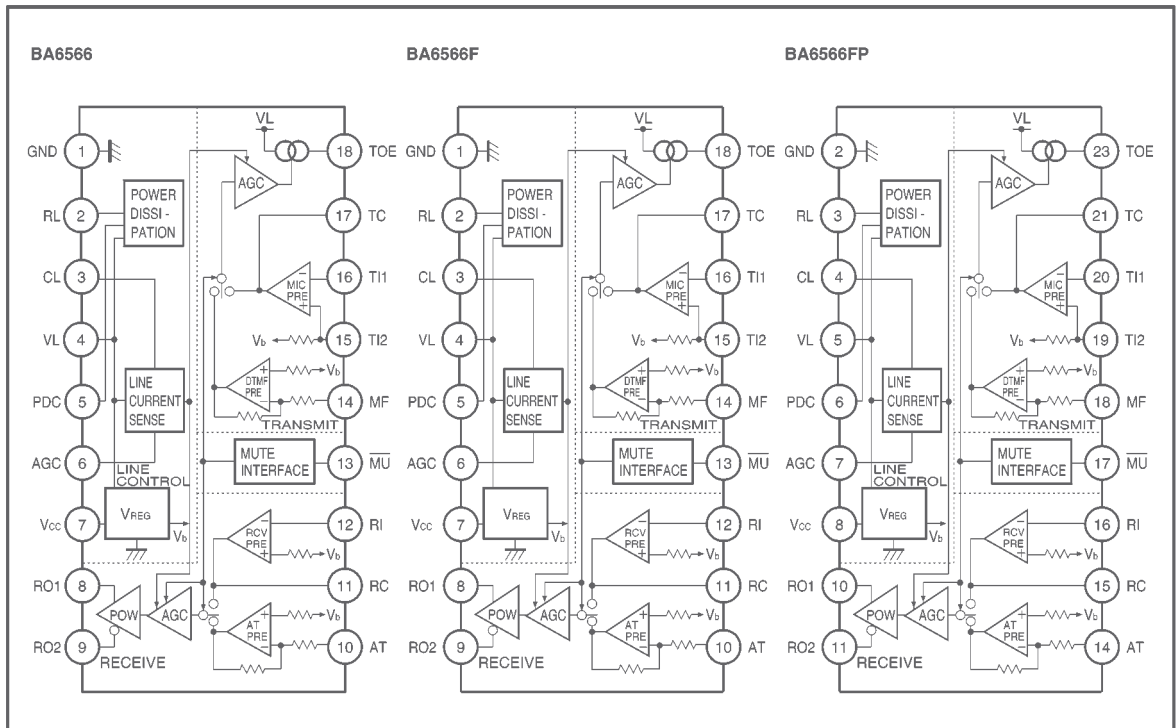

● Absolute maximum ratings (Ta=25°C)

Parameter	Symbol	Limits	Unit
Applied voltage	V _L	16.5	V
Power dissipation	BA6566	1100* ¹	mW
	BA6566F	600* ²	
	BA6566FP	1350* ³	
Operating temperature	T _{opr}	-35~+60	°C
Storage temperature	T _{stg}	-55~+125	°C
Current dissipation	I _L	125* ⁴	mA

*1 Reduced by 11 mW for each increase in Ta of 1°C over 25°C.

*2 Reduced by 6 mW for each increase in Ta of 1°C over 25°C.

*3 Reduced by 13.5 mW for each increase in Ta of 1°C over 25°C.

When mounted on 90 mm × 50 mm × 1.6 mm glass epoxy board, fins should be soldered to foil pattern.

*4 With the BA6566, Reduced by 1 mA for each increase in Ta of 1°C over 50°C.

With the BA6566F, Reduced by 1.4 mA for each increase in Ta of 1°C over 50°C.

With the BA6566FP, Reduced by 1 mA for each increase in Ta of 1°C over 50°C.

●Electrical characteristics (Ta=25°C)

Parameter	Symbol	Min.	Typ.	Max.	Unit	Conditions				Measurement circuit
						I _L (mA)	AGC	Mute	f=1kHz	
Line voltage (5)	V _L (5)	—	2.0	—	V	5	—	—	—	Fig.2
Line voltage (20)	V _L (20)	2.5	3.5	5.0	V	20	—	—	—	Fig.2
Line voltage (30)	V _L (30)	3.0	4.0	5.4	V	30	—	—	—	Fig.2
Line voltage (90)	V _L (90)	5.2	7.0	9.5	V	90	—	—	—	Fig.2
Mute input low level voltage	V _{IL}	0.1	0.18	0.25	V	20~90	—	—	—	Fig.2
Mute input low level current	I _{IL}	25	35	45	μA	20~90	—	—	—	Fig.2
Transmit gain 1 (20 - 90)	G _{T1} (20 - 90)	37	41	44	dB	20~90	OFF	OFF	V _{IN} =-50dBV	Fig.3
Transmit gain 1 (30 - 90)	G _{T1} (30 - 90)	38	41	44	dB	30~90	OFF	OFF	V _{IN} =-50dBV	Fig.3
Transmit gain 2 (20)	G _{T2} (20)	38	41	45	dB	20	ON	OFF	V _{IN} =-50dBV	Fig.3
Transmit gain 2 (30)	G _{T2} (30)	38	41	44	dB	30	ON	OFF	V _{IN} =-50dBV	Fig.3
Transmit gain 2 (90)	G _{T2} (90)	34.5	37.5	40.5	dB	90	ON	OFF	V _{IN} =-50dBV	Fig.3
Transmit distortion attenuation	D _T	—	-46	-20	dB	20~90	—	OFF	V _{IN} =-50dBV	Fig.3
Transmit noise level	N _T	—	-68	-55	dBV	20~90	—	OFF	BPF=400Hz ~30kHz	Fig.3
Maximum transmit output level (20 - 90)	O _T (20 - 90)	-2	3	—	dBV	20~90	—	OFF	Dist=-20dB	Fig.3
Maximum transmit output level (30 - 90)	O _T (30 - 90)	0	3	—	dBV	30~90	—	OFF	Dist=-20dB	Fig.3
Receive gain 1 (20 - 90)	G _{R1} (20 - 90)	-13	-10	-7	dB	20~90	OFF	OFF	S _i =1 V _{IN} =-20dBV	Fig.4
Receive gain 1 (20)	G _{R1} (20)	-13	-10	-7	dB	20	ON	OFF	S _i =1 V _{IN} =-20dBV	Fig.4
Receive gain 1 (30)	G _{R1} (30)	-13	-10	-7	dB	30	ON	OFF	S _i =1 V _{IN} =-20dBV	Fig.4
Receive gain 1 (90)	G _{R1} (90)	-16.5	-13.5	-10.5	dB	90	ON	OFF	S _i =1 V _{IN} =-20dBV	Fig.4
Receive distortion attenuation 1	D _{R1}	—	-46	-20	dB	20~90	—	OFF	S _i =1 V _{IN} =-20dBV	Fig.4
Receive noise level 1	N _{R1}	—	-70	-60	dBV	20~90	—	OFF	BPF=400Hz ~30kHz	Fig.4
Maximum receive output level 1 (20 - 90)	O _{R1} (20 - 90)	-15	-7	—	dBV	20~90	—	OFF	Dist=-20dB	Fig.4
Maximum receive output level 1 (30 - 90)	O _{R1} (30 - 90)	-11	-7	—	dBV	30~90	—	OFF	Dist=-20dB	Fig.4
Receive gain 2 (20 - 90)	G _{R2} (20 - 90)	5	8	11	dB	20~90	OFF	OFF	S _i =2 V _{IN} =-20dBV	Fig.4
Receive gain 2 (20)	G _{R2} (20)	5	8	11	dB	20	ON	OFF	S _i =2 V _{IN} =-20dBV	Fig.4

Parameter	Symbol	Min.	Typ.	Max.	Unit	Conditions				Measurement circuit
						I _L (mA)	AGC	Mute	f=1kHz	
Receive gain 2 (30)	G _{R2} (30)	5	8	11	dB	30	ON	OFF	S ₁ =2 V _{IN} =-20dBV	Fig.4
Receive gain 2 (90)	G _{R2} (90)	1.5	4.5	7.5	dB	90	ON	OFF	S ₁ =2 V _{IN} =-20dBV	Fig.4
Receive distortion attenuation 2	D _{R2}	—	-46	-20	dB	20~90	—	OFF	S ₁ =2 V _{IN} =-20dBV	Fig.4
Receive noise level (20 - 90)	N _{R2} (20 - 90)	—	-66	-50	dBV	20~90	—	OFF	BPF=400Hz ~30kHz	Fig.4
Receive noise level 2 (30 - 90)	N _{R2} (30 - 90)	—	-66	-55	dBV	30~90	—	OFF	BPF=400Hz ~30kHz	Fig.4
Maximum receive output level 2 (20 - 90)	O _{R2} (20 - 90)	1	7	—	dBV	20~90	—	OFF	Dist=-20dB	Fig.4
Maximum receive output level 2 (30 - 90)	O _{R2} (30 - 90)	3	7	—	dBV	30~90	—	OFF	Dist=-20dB	Fig.4
DTMF gain 1 (20 - 90)	G _{D1} (20 - 90)	30.5	33.5	36.5	dB	20~90	OFF	ON	V _{IN} =-40dBV	Fig.5
DTMF gain 2 (20)	G _{D1} (20)	30	33	36	dB	20	ON	ON	V _{IN} =-40dBV	Fig.5
DTMF gain 2 (30)	G _{D2} (30)	30	33	36	dB	30	ON	ON	V _{IN} =-40dBV	Fig.5
DTMF gain 2 (90)	G _{D2} (90)	27	30	33	dB	90	ON	ON	V _{IN} =-40dBV	Fig.5
DTMF distortion attenuation	D _D	—	-41	-28	dB	20~90	—	ON	V _{IN} =-40dBV	Fig.5
DTMF noise level (20 - 90)	N _D	—	-64	-55	dBV	20~90	—	ON	BPF=400Hz ~30kHz	Fig.5
Maximum DTMF output level (20 - 90)	O _D (20 - 90)	-4.5	-0.5	—	dBV	20~90	—	ON	Dist=-28dB	Fig.5
Maximum DTMF output level (30 - 90)	O _D (30 - 90)	-3.5	-0.5	—	dBV	30~90	—	ON	Dist=-28dB	Fig.5
AT gain 1	G _{A1}	23.5	26.5	29.5	dB	20~90	—	ON	S ₁ =1 V _{IN} =-40dBV	Fig.6
AT gain 2	G _{A2}	26.5	29.5	32.5	dB	20~90	—	ON	S ₁ =2 V _{IN} =-40dBV	Fig.6
AC impedance	Z _{TEL}	450	565	750	Ω	20~90	—	—	V _{IN} =-20dBV	Fig.7
V _{CC} pin voltage	V _{CCR}	1.15	1.27	—	V	20	—	—	S ₃ =ON	Fig.2

● Measurement circuits

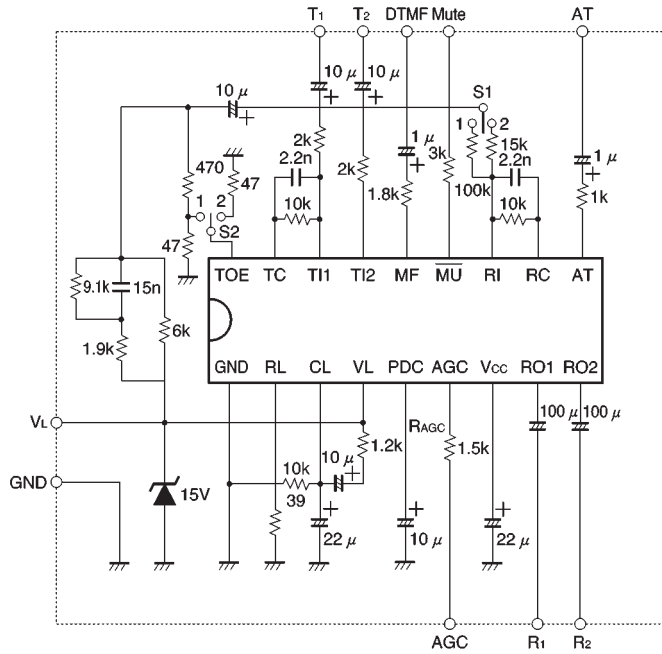

Fig. 1

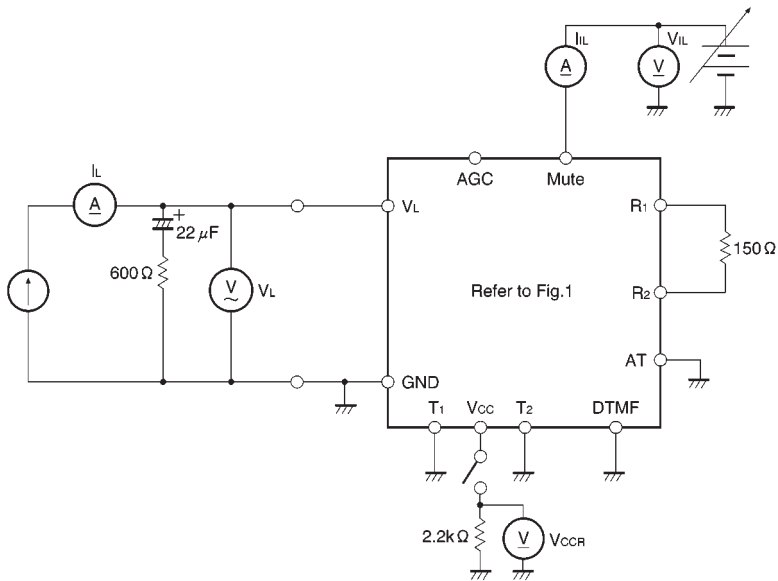

Fig. 2

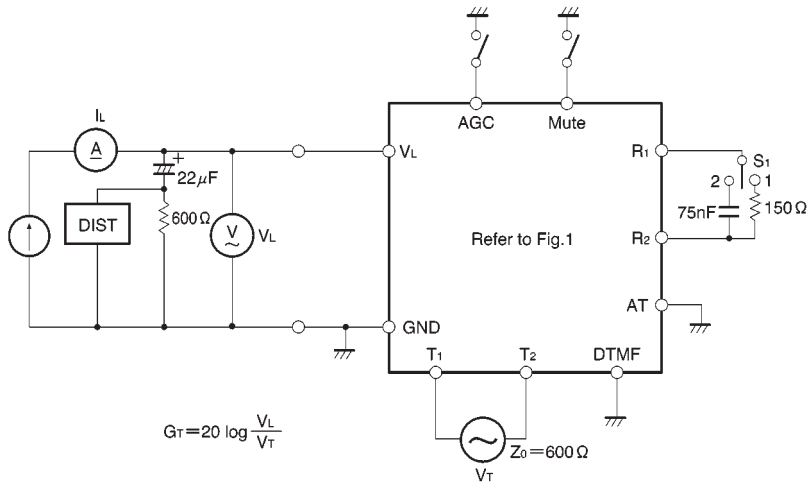

Fig. 3

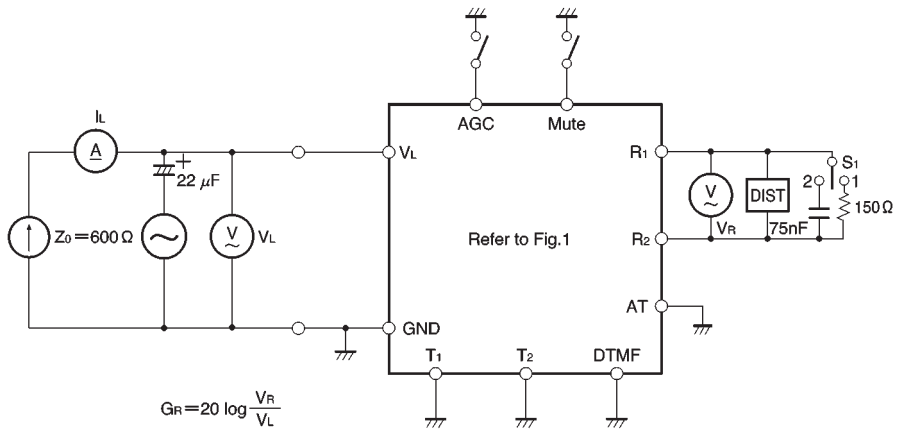

Fig. 4

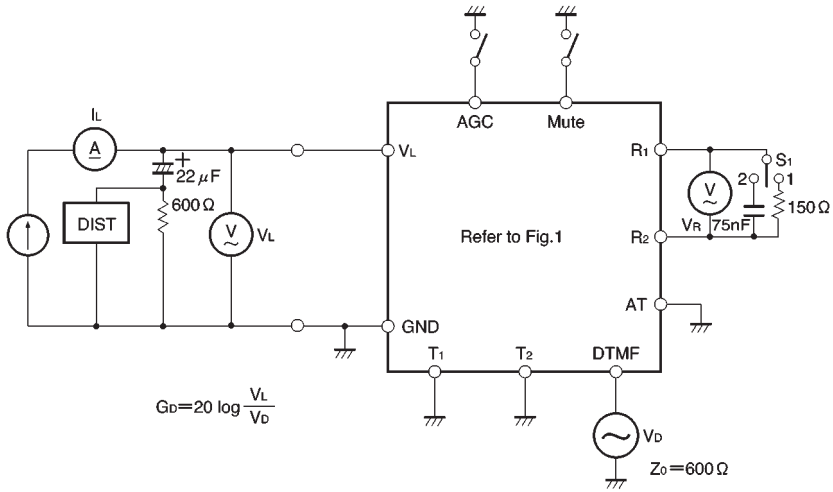

Fig. 5

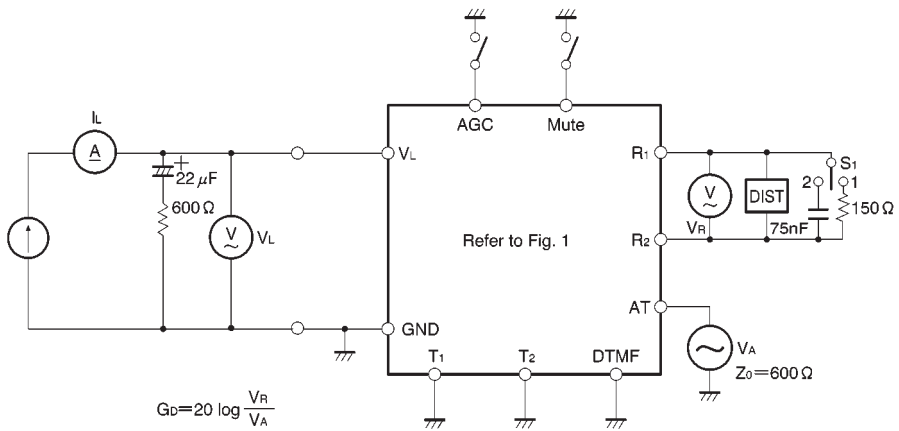

Fig. 6

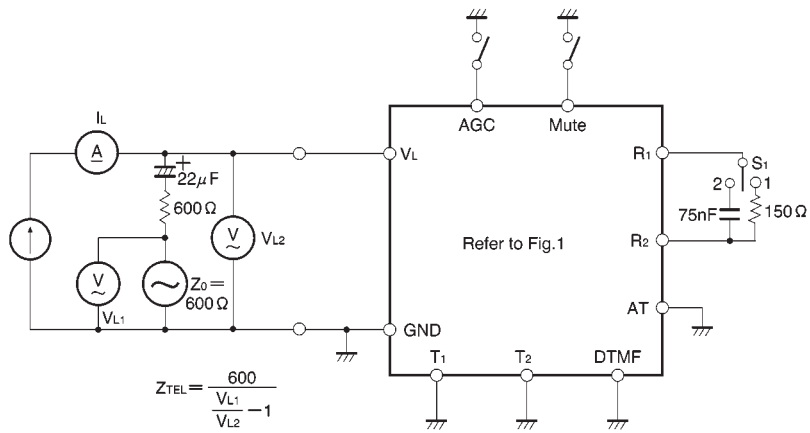

Fig. 7

● External dimensions (Units: mm)

