

阅读申明

- 1.本站收集的数据手册和产品资料都来自互联网，版权归原作者所有。如读者和版权方有任何异议请及时告之，我们将妥善解决。
- 2.本站提供的中文数据手册是英文数据手册的中文翻译，其目的是协助用户阅读，该译文无法自动跟随原稿更新，同时也可能存在翻译上的不当。建议读者以英文原稿为参考以便获得更精准的信息。
- 3.本站提供的产品资料，来自厂商的技术支持或者使用者的心得体会等，其内容可能存在描述上的差异，建议读者做出适当判断。
- 4.如需与我们联系，请发邮件到marketing@iczoom.com，主题请标有“数据手册”字样。

Read Statement

1. The datasheets and other product information on the site are all from network reference or other public materials, and the copyright belongs to the original author and original published source. If readers and copyright owners have any objections, please contact us and we will deal with it in a timely manner.
2. The Chinese datasheets provided on the website is a Chinese translation of the English datasheets. Its purpose is for reader's learning exchange only and do not involve commercial purposes. The translation cannot be automatically updated with the original manuscript, and there may also be improper translations. Readers are advised to use the English manuscript as a reference for more accurate information.
3. All product information provided on the website refer to solutions from manufacturers' technical support or users the contents may have differences in description, and readers are advised to take the original article as the standard.
4. If you have any questions, please contact us at marketing@iczoom.com and mark the subject with "Datasheets" .

General Description

Jumper Description

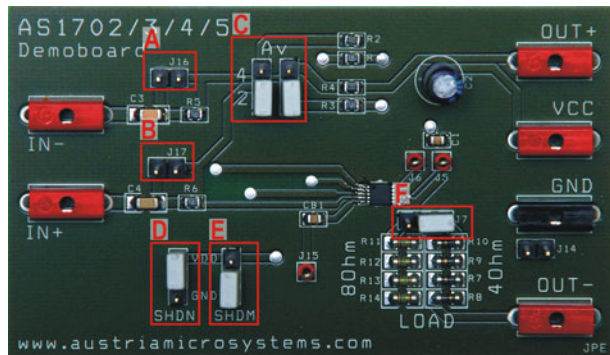

Mark	Jumper	Description	Set	Not Set
A	J16	R _{IN} of IN-	R _{IN} disabled	R _{IN} enabled
B	J17	R _{IN} of IN+	R _{IN} disabled	R _{IN} enabled
C	Av	Gain of the Amplifier*	Av = 2 Av = 4	For AS1703/04/05 only
D	SHDN	Shutdown	or Shutdown Mode enabled,	Not recommended
E	SHDM	Shutdown Mode	or Normal Operation enabled	
F	J7	Output Impedance	Load = 80Ohm Load = 40Ohm	Load = 0Ohm

*) Gain settings only applicable for AS1702

Measurement Points Description

Mark	Pin	Description
G	J14	Ground
H	J15	Measurement Point of BIAS-GND
I	J6	Measurement Point of OUT+
J	J5	Measurement Point of OUT-

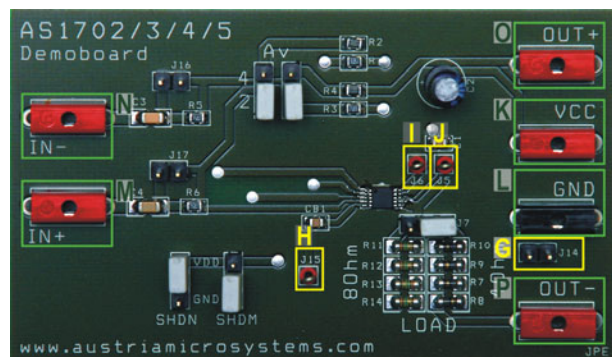

Input/Output Description

Mark	Connector	Description
K	VCC	Power Supply Connectors for VCC and GND.
L	GND	
M	IN+	Input Connectors for differential signal source.
N	IN-	
O	OUT+	Outputs Connectors.
P	OUT-	

Circuit

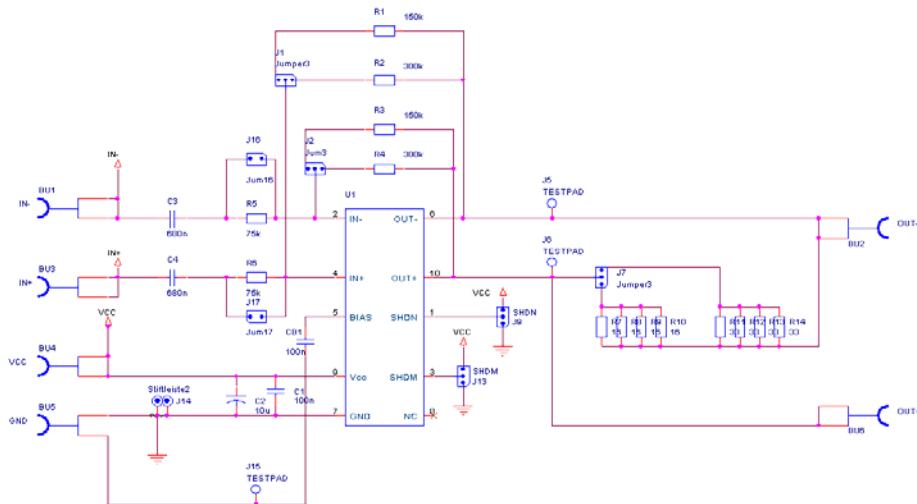

Starting Up

Soldered Chip

The AS1702/3/4/5 demo board is designed to work with the AS1702, AS1703, AS1704 and the AS1705. Before using the Demoboard please make sure which chip is on the board and set the Jumpers appropriate if necessary. The marking of the chip can be found printed on the IC soldered on the board.

Per default an AS1702 is mounted on the Demoboard

Two different Jumper settings are necessary, one for the AS1702 and another for the AS1703/04/05.

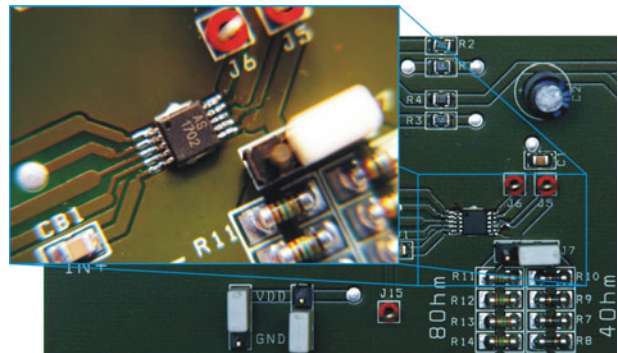

If an AS1703, AS1704, AS1705 is soldered, set the following jumpers:

Mark	Jumper	Description	Jumper Set	Value
A	J16	R _{IN} of IN-	SET	R _{IN} = 0kOhm
B	J17	R _{IN} of IN+	SET	R _{IN} = 0kOhm
C	Av	Gain of the Amplifier	NOT SET	Gain of IC. See datasheet.
D	SHDN	Shutdown	SET (2 values possible)	VDD/GND
E	SHDM	Shutdown Mode	SET (2 values possible)	VDD/GND
F	J7	Output Impedance	OPTIONAL (3 values possible)	Load = 0 / 4 / 80hm

If an AS1702 is soldered, set the following jumpers:

Mark	Jumper	Description	Jumper Set	Value
A	J16	R _{IN} of IN-	NOT SET	R _{IN} = 75kOhm
B	J17	R _{IN} of IN+	NOT SET	R _{IN} = 75kOhm
C	Av	Gain of the Amplifier	SET (2 values possible)	Av = 2 / 4 (6dB / 12dB)
D	SHDN	Shutdown	SET (2 values possible)	VDD/GND
E	SHDM	Shutdown Mode	SET (2 values possible)	VDD/GND
F	J7	Output Impedance	OPTIONAL (3 values possible)	Load = 0 / 4 / 80hm

Operational sequence

1. If not present get the datasheet for the AS1702/03/04/05 from www.austriamicrosystems.com. Drive the IC on the Demoboard only with the recommended settings and values as described in the datasheet.
2. Make sure which IC is soldered on the Demoboard.
3. Set Jumper as described above.
 - Choose an output impedance.
 - Choose the gain.
4. Connect a 2.7 to 5.5V power supply (VDD and GND).
5. Connect a **differential** signal source. For example differential sinus signal.
6. Measure on the measuring points J6(OUT+) and J5(OUT-) and J15(BIAS-GND).

Note: It's possible to connect headphones or speakers (40hm or 80hm Impedance) to the outputs. Make sure the onboard Output Impedance is set to 00hm with removing Jumper J7 (F).

Have fun using the Demoboard. If there are questions do not hesitate to contact us. See contact information below.

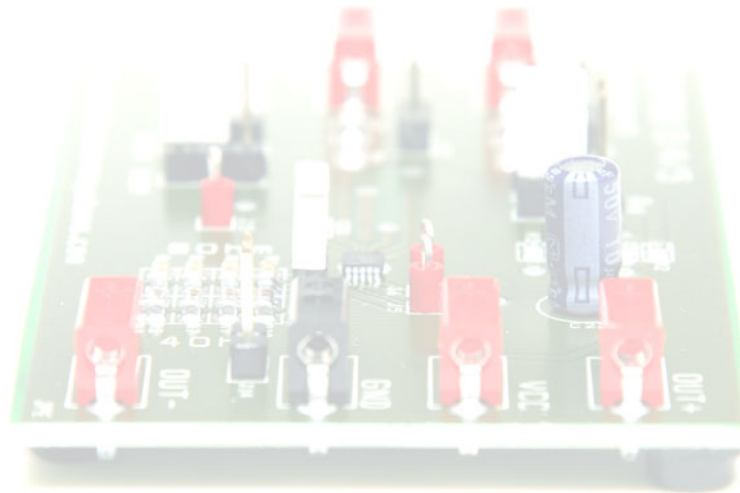

Copyright

Copyright © 2005 austriamicrosystems. Trademarks registered ®. All rights reserved. The material herein may not be reproduced, adapted, merged, translated, stored, or used without the prior written consent of the copyright owner. To the best of its knowledge, austriamicrosystems asserts that the information contained in this publication is accurate and correct.

Contact Information

Headquarters:

austriamicrosystems AG
Standard Linear
A 8141 Schloss Premstätten, Austria
T. +43 (0) 3136 500 0
F. +43 (0) 3136 5692
info@austriamicrosystems.com

For Sales Offices, Distributors and Representatives, please visit: www.austriamicrosystems.com