

## 阅读申明

- 1.本站收集的数据手册和产品资料都来自互联网，版权归原作者所有。如读者和版权方有任何异议请及时告之，我们将妥善解决。
- 2.本站提供的中文数据手册是英文数据手册的中文翻译，其目的是协助用户阅读，该译文无法自动跟随原稿更新，同时也可能存在翻译上的不当。建议读者以英文原稿为参考以便获得更精准的信息。
- 3.本站提供的产品资料，来自厂商的技术支持或者使用者的心得体会等，其内容可能存在描述上的差异，建议读者做出适当判断。
- 4.如需与我们联系，请发邮件到marketing@iczoom.com，主题请标有“数据手册”字样。

## Read Statement

1. The datasheets and other product information on the site are all from network reference or other public materials, and the copyright belongs to the original author and original published source. If readers and copyright owners have any objections, please contact us and we will deal with it in a timely manner.
2. The Chinese datasheets provided on the website is a Chinese translation of the English datasheets. Its purpose is for reader's learning exchange only and do not involve commercial purposes. The translation cannot be automatically updated with the original manuscript, and there may also be improper translations. Readers are advised to use the English manuscript as a reference for more accurate information.
3. All product information provided on the website refer to solutions from manufacturers' technical support or users the contents may have differences in description, and readers are advised to take the original article as the standard.
4. If you have any questions, please contact us at marketing@iczoom.com and mark the subject with "Datasheets" .

# TPA0243 2-W MONO AUDIO POWER AMPLIFIER WITH HEADPHONE DRIVE

SLOS279C – JANUARY 2000 – REVISED NOVEMBER 2002

- Ideal for Notebook Computers, PDAs, and Other Small Portable Audio Devices
- 2 W Into 4- $\Omega$  From 5-V Supply
- 0.6 W Into 4- $\Omega$  From 3-V Supply
- Stereo Head Phone Drive
- Mono (BTL) Signal Created by Summing Left and Right Signals
- Wide Power Supply Compatibility  
3 V to 5 V
- Meets PC99 Desktop Specs (target)
- Low Supply Current
  - 10 mA Typical at 5 V
  - 9 mA Typical at 3 V
- Shutdown Control . . . 1  $\mu$ A Typical
- Shutdown Pin Is TTL Compatible
- –40°C to 85°C Operating Temperature Range
- Space-Saving, Thermally-Enhanced MSOP Packaging

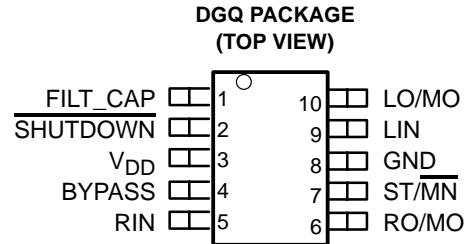

## description

The TPA0243 is a 2-W mono bridge-tied-load (BTL) amplifier designed to drive speakers with as low as 4- $\Omega$  impedance. The mono signal is created by summing left and right inputs. The amplifier can be reconfigured on the fly to drive two stereo single-ended (SE) signals into headphones. This makes the device ideal for small notebook computers, PDAs, digital personal audio players, anyplace a mono speaker and stereo headphones are required. From a 5-V supply, the TPA0243 can deliver 2 W of power into a 4- $\Omega$  speaker.

The gain of the input stage is set by the user-selected input resistor and a 50-k $\Omega$  internal feedback resistor ( $A_V = -R_F/R_I$ ). The power stage is internally configured with a gain of –1.25 V/V in SE mode, and –2.5 V/V in BTL mode. Thus, the overall gain of the amplifier is 62.5 k $\Omega/R_I$  in SE mode and 125 k $\Omega/R_I$  in BTL mode. The input terminals are high-impedance CMOS inputs, and can be used as summing nodes.

The TPA0243 is available in the 10-pin thermally-enhanced MSOP package (DGQ) and operates over an ambient temperature range of –40°C to 85°C.



Please be aware that an important notice concerning availability, standard warranty, and use in critical applications of Texas Instruments semiconductor products and disclaimers thereto appears at the end of this data sheet.

PRODUCTION DATA information is current as of publication date. Products conform to specifications per the terms of Texas Instruments standard warranty. Production processing does not necessarily include testing of all parameters.

 **TEXAS  
INSTRUMENTS**

POST OFFICE BOX 655303 • DALLAS, TEXAS 75265

Copyright © 2002, Texas Instruments Incorporated

# TPA0243 2-W MONO AUDIO POWER AMPLIFIER WITH HEADPHONE DRIVE

SLOS279C – JANUARY 2000 – REVISED NOVEMBER 2002

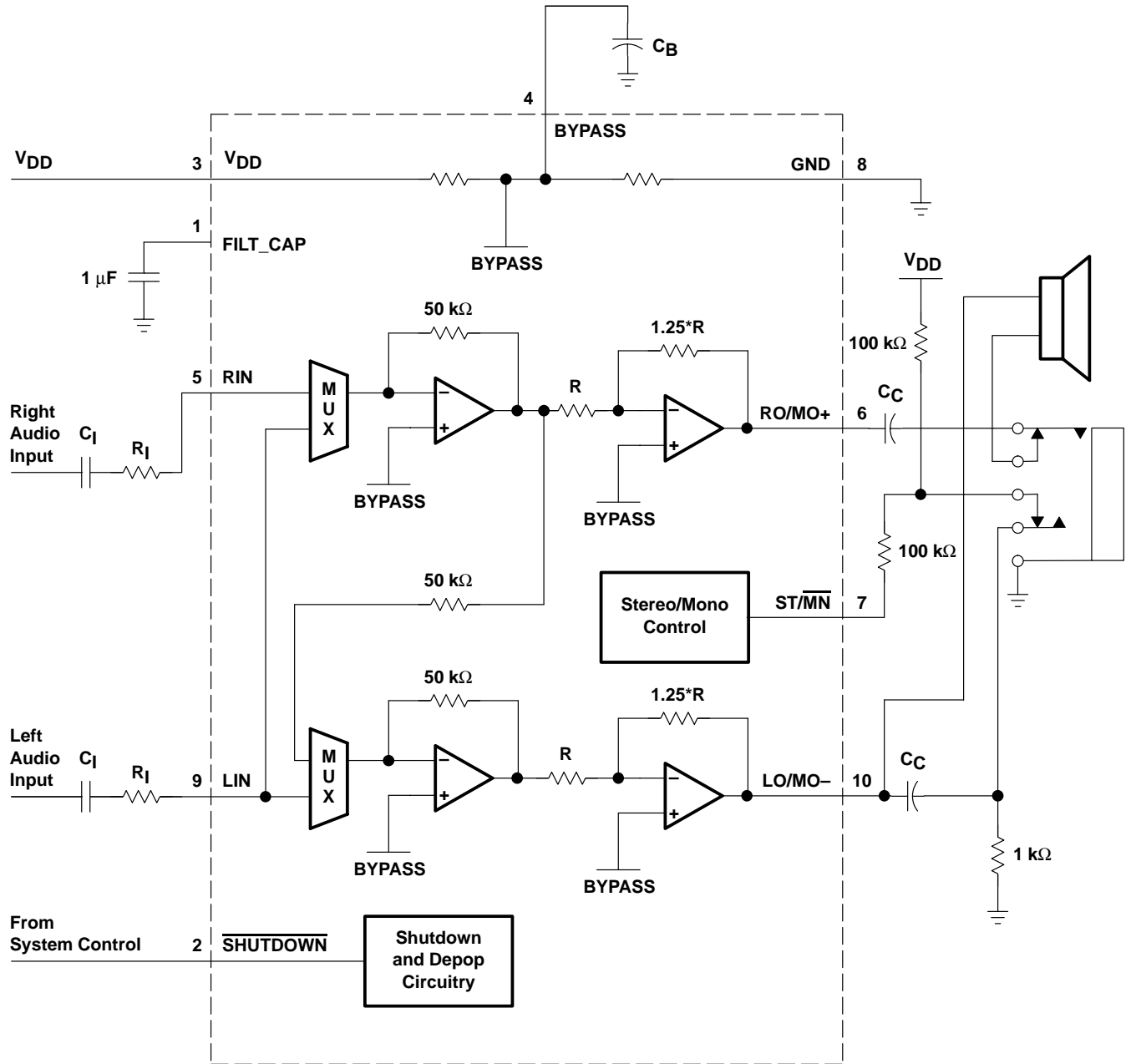

### AVAILABLE OPTIONS

T <sub>A</sub>	PACKAGED DEVICES	MSOP SYMBOLIZATION
	MSOP† (DGQ)	
-40°C to 85°C	TPA0243DGQ	AEK

† The DGQ package are available taped and reeled. To order a taped and reeled part, add the suffix R to the part number (e.g., TPA0243DGQR).



### Terminal Functions

TERMINAL NAME	NO.	I/O	DESCRIPTION
BYPASS	4	I	BYPASS is the tap to the voltage divider for internal mid-supply bias. This terminal should be connected to a 0.1- $\mu$ F to 1- $\mu$ F capacitor.
GND	8		Ground terminal
LIN	9	I	Left-channel input terminal
LO/MO	10	O	Left-output in SE mode and mono negative output in BTL mode.
MONO-IN	1	I	Terminal used to filter supply
RIN	5	I	Right-channel input terminal
RO/MO	6	O	Right-output in SE mode and mono positive output in BTL mode
$\overline{\text{SHUTDOWN}}$	2	I	$\overline{\text{SHUTDOWN}}$ places the entire device in shutdown mode when held low. TTL compatible input.
$\overline{\text{ST/MN}}$	7	I	Selects between Stereo and Mono mode. When held high, the amplifier is in SE stereo mode; while held low, the amplifier is in BTL mono mode.
$V_{DD}$	3	I	$V_{DD}$ is the supply voltage terminal.

### absolute maximum ratings over operating free-air temperature range (unless otherwise noted)<sup>†</sup>

Supply voltage, $V_{DD}$	6 V
Input voltage range, $V_I$	-0.3 V to $V_{DD} + 0.3$ V
Continuous total power dissipation	internally limited (see Dissipation Rating Table)
Operating free-air temperature range, $T_A$ (see Table 3)	-40°C to 85°C
Operating junction temperature range, $T_J$	-40°C to 150°C
Storage temperature range, $T_{stg}$	-65°C to 150°C
Lead temperature 1,6 mm (1/16 inch) from case for 10 seconds	260°C

<sup>†</sup> Stresses beyond those listed under "absolute maximum ratings" may cause permanent damage to the device. These are stress ratings only, and functional operation of the device at these or any other conditions beyond those indicated under "recommended operating conditions" is not implied. Exposure to absolute-maximum-rated conditions for extended periods may affect device reliability.

**DISSIPATION RATING TABLE**

PACKAGE	$T_A \leq 25^\circ\text{C}$	DERATING FACTOR	$T_A = 70^\circ\text{C}$	$T_A = 85^\circ\text{C}$
DGQ	2.14 W <sup>‡</sup>	17.1 mW/°C	1.37 W	1.11 W

<sup>‡</sup> See *PowerPAD Thermally Enhanced Package Application Report (SLMA002)* for more information on the PowerPAD™ package. The thermal data was measured on a PCB layout based on the information in the section entitled *Texas Instruments Recommended Board for PowerPAD* on page 33 of that document.

### recommended operating conditions

			MIN	MAX	UNIT
Supply voltage, $V_{DD}$			2.5	5.5	V
High-level input voltage, $V_{IH}$	$\overline{\text{ST/MN}}$	$V_{DD} = 3$ V	2.7		V
		$V_{DD} = 5$ V	4.5		
	$\overline{\text{SHUTDOWN}}$		2		
Low-level input voltage, $V_{IL}$	$\overline{\text{ST/MN}}$	$V_{DD} = 3$ V		1.65	V
		$V_{DD} = 5$ V		2.75	
	$\overline{\text{SHUTDOWN}}$			0.8	
Operating free-air temperature, $T_A$			-40	85	°C

PowerPAD is a trademark of Texas Instruments.



**TPA0243**  
**2-W MONO AUDIO POWER AMPLIFIER**  
**WITH HEADPHONE DRIVE**

SLOS279C – JANUARY 2000 – REVISED NOVEMBER 2002

**electrical characteristics at specified free-air temperature,  $V_{DD} = 3\text{ V}$ ,  $T_A = 25^\circ\text{C}$  (unless otherwise noted)**

PARAMETER	TEST CONDITIONS	MIN	TYP	MAX	UNIT
$ V_{OO} $ Output offset voltage (measured differentially)	SHUTDOWN = 2 V, ST/MN = 0, $R_L = 4\ \Omega$			30	mV
$I_{DD}$ Supply current	$V_{DD} = 2.5\text{ V}$ , SHUTDOWN = 2 V		9	14	mA
$I_{DD(SD)}$ Supply current, shutdown mode	SHUTDOWN = 0 V		1	10	$\mu\text{A}$
$ I_{IH} $ High-level input current	SHUTDOWN, $V_{DD} = 3.3\text{ V}$ , $V_I = V_{DD}$			1	$\mu\text{A}$
	ST/MN, $V_{DD} = 3.3\text{ V}$ , $V_I = V_{DD}$			1	
$ I_{IL} $ Low-level input current	SHUTDOWN, $V_{DD} = 3.3\text{ V}$ , $V_I = 0\text{ V}$			1	$\mu\text{A}$
	ST/MN, $V_{DD} = 3.3\text{ V}$ , $V_I = 0\text{ V}$			1	
$R_F$ Feedback resistor	$V_{DD} = 2.5\text{ V}$ , $R_L = 4\ \Omega$ , ST/MN = 1.375 V, SHUTDOWN = 2 V	47	50	57	k $\Omega$

**operating characteristics,  $V_{DD} = 3\text{ V}$ ,  $T_A = 25^\circ\text{C}$ ,  $R_L = 4\ \Omega$**

PARAMETER	TEST CONDITIONS	MIN	TYP	MAX	UNIT
$P_O$ Output power, see Note 1	THD = 1%, BTL mode		660		mW
	THD = 0.1%, SE mode, $R_L = 32\ \Omega$		34		
THD + N Total harmonic distortion plus noise	$P_O = 500\text{ mW}$ , $f = 20\text{ Hz to }20\text{ kHz}$		0.3%		
BOM Maximum output power bandwidth	Gain = 2, THD = 2%		20		kHz

NOTE 1: Output power is measured at the output terminals of the device at  $f = 1\text{ kHz}$ .

**electrical characteristics at specified free-air temperature,  $V_{DD} = 5\text{ V}$ ,  $T_A = 25^\circ\text{C}$  (unless otherwise noted)**

PARAMETER	TEST CONDITIONS	MIN	TYP	MAX	UNIT
$ V_{OO} $ Output offset voltage (measured differentially)	SHUTDOWN = 2 V, ST/MN = 0, $R_L = 4\ \Omega$			30	mV
$I_{DD}$ Supply current	SHUTDOWN = 2 V		10	15	mA
$I_{DD(SD)}$ Supply current, shutdown mode	SHUTDOWN = 0 V		1	10	$\mu\text{A}$
$ I_{IH} $ High-level input current	SHUTDOWN, $V_{DD} = 5.5\text{ V}$ , $V_I = V_{DD}$			1	$\mu\text{A}$
	ST/MN, $V_{DD} = 5.5\text{ V}$ , $V_I = V_{DD}$			1	
$ I_{IL} $ Low-level input current	SHUTDOWN, $V_{DD} = 5.5\text{ V}$ , $V_I = 0\text{ V}$			1	$\mu\text{A}$
	ST/MN, $V_{DD} = 5.5\text{ V}$ , $V_I = 0\text{ V}$			1	

**operating characteristics,  $V_{DD} = 5\text{ V}$ ,  $T_A = 25^\circ\text{C}$ ,  $R_L = 4\ \Omega$**

PARAMETER	TEST CONDITIONS	MIN	TYP	MAX	UNIT
$P_O$ Output power, see Note 1	THD = 1%, BTL mode		2		W
	THD = 0.1%, SE mode, $R_L = 32\ \Omega$		95		
THD + N Total harmonic distortion plus noise	$P_O = 1\text{ W}$ , $f = 20\text{ Hz to }20\text{ kHz}$		0.2%		
BOM Maximum output power bandwidth	Gain = 2.5, THD = 2%		20		kHz

NOTE 1: Output power is measured at the output terminals of the device at  $f = 1\text{ kHz}$ .



TPA0243  
**2-W MONO AUDIO POWER AMPLIFIER  
 WITH HEADPHONE DRIVE**

SLOS279C – JANUARY 2000 – REVISED NOVEMBER 2002

**MECHANICAL DATA**

**DGQ (S-PDSO-G10)**

**PowerPAD™ PLASTIC SMALL-OUTLINE PACKAGE**

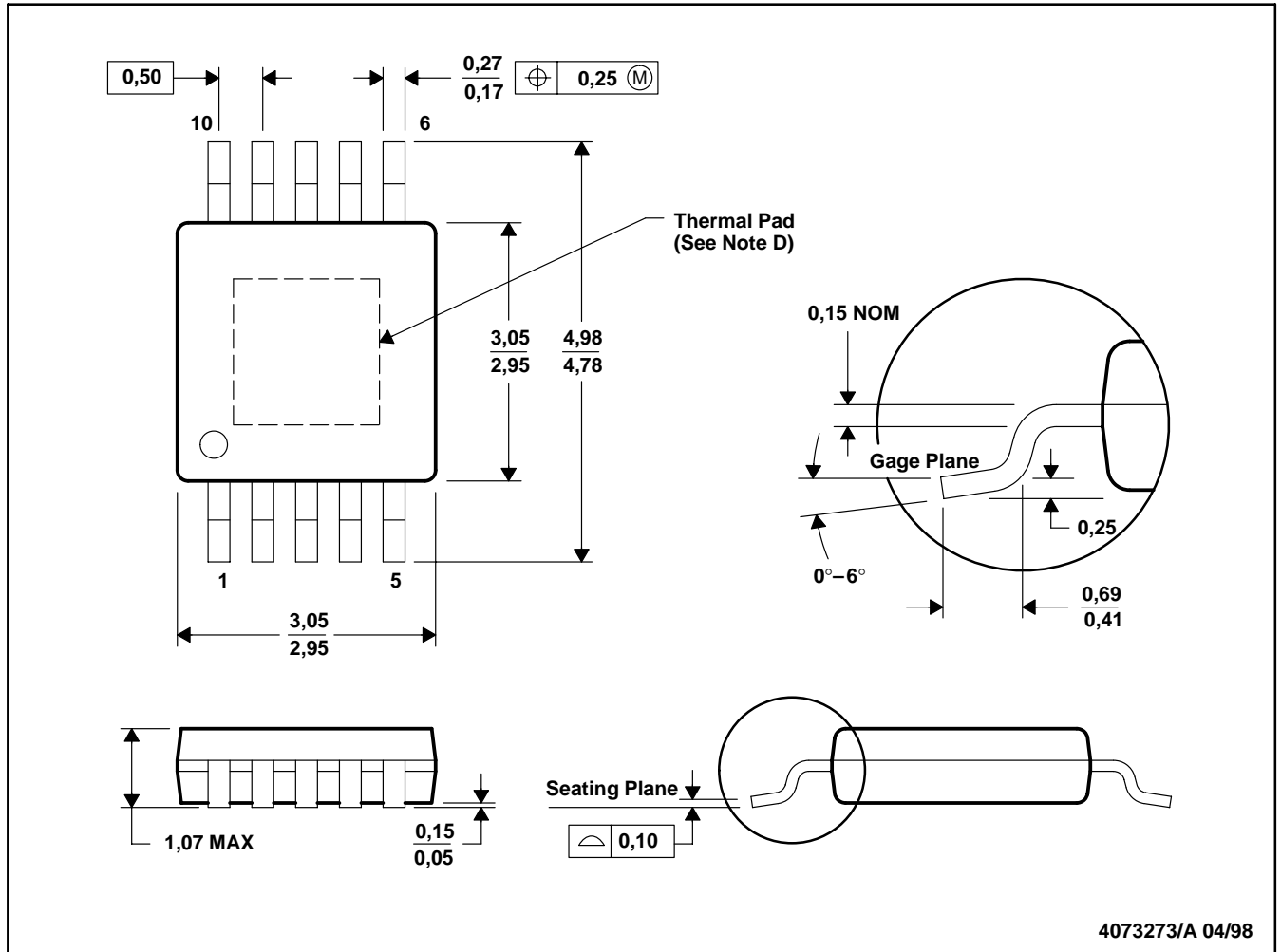

4073273/A 04/98

- NOTES: A. All linear dimensions are in millimeters.  
 B. This drawing is subject to change without notice.  
 C. Body dimensions do not include mold flash or protrusion.  
 D. The package thermal performance may be enhanced by bonding the thermal pad to an external thermal plane. This pad is electrically and thermally connected to the backside of the die and possibly selected leads.

PowerPAD is a trademark of Texas Instruments.



POST OFFICE BOX 655303 • DALLAS, TEXAS 75265

**PACKAGING INFORMATION**

Orderable Device	Status <sup>(1)</sup>	Package Type	Package Drawing	Pins	Package Qty	Eco Plan <sup>(2)</sup>	Lead/Ball Finish	MSL Peak Temp <sup>(3)</sup>
TPA0243DGQ	ACTIVE	MSOP-Power PAD	DGQ	10	80	None	CU SNPB	Level-1-220C-UNLIM
TPA0243DGQR	ACTIVE	MSOP-Power PAD	DGQ	10	2500	None	CU SNPB	Level-1-220C-UNLIM

<sup>(1)</sup> The marketing status values are defined as follows:

**ACTIVE:** Product device recommended for new designs.

**LIFEBUY:** TI has announced that the device will be discontinued, and a lifetime-buy period is in effect.

**NRND:** Not recommended for new designs. Device is in production to support existing customers, but TI does not recommend using this part in a new design.

**PREVIEW:** Device has been announced but is not in production. Samples may or may not be available.

**OBSOLETE:** TI has discontinued the production of the device.

<sup>(2)</sup> Eco Plan - May not be currently available - please check <http://www.ti.com/productcontent> for the latest availability information and additional product content details.

**None:** Not yet available Lead (Pb-Free).

**Pb-Free (RoHS):** TI's terms "Lead-Free" or "Pb-Free" mean semiconductor products that are compatible with the current RoHS requirements for all 6 substances, including the requirement that lead not exceed 0.1% by weight in homogeneous materials. Where designed to be soldered at high temperatures, TI Pb-Free products are suitable for use in specified lead-free processes.

**Green (RoHS & no Sb/Br):** TI defines "Green" to mean "Pb-Free" and in addition, uses package materials that do not contain halogens, including bromine (Br) or antimony (Sb) above 0.1% of total product weight.

<sup>(3)</sup> MSL, Peak Temp. -- The Moisture Sensitivity Level rating according to the JEDEC industry standard classifications, and peak solder temperature.

**Important Information and Disclaimer:** The information provided on this page represents TI's knowledge and belief as of the date that it is provided. TI bases its knowledge and belief on information provided by third parties, and makes no representation or warranty as to the accuracy of such information. Efforts are underway to better integrate information from third parties. TI has taken and continues to take reasonable steps to provide representative and accurate information but may not have conducted destructive testing or chemical analysis on incoming materials and chemicals. TI and TI suppliers consider certain information to be proprietary, and thus CAS numbers and other limited information may not be available for release.

In no event shall TI's liability arising out of such information exceed the total purchase price of the TI part(s) at issue in this document sold by TI to Customer on an annual basis.

## IMPORTANT NOTICE

Texas Instruments Incorporated and its subsidiaries (TI) reserve the right to make corrections, modifications, enhancements, improvements, and other changes to its products and services at any time and to discontinue any product or service without notice. Customers should obtain the latest relevant information before placing orders and should verify that such information is current and complete. All products are sold subject to TI's terms and conditions of sale supplied at the time of order acknowledgment.

TI warrants performance of its hardware products to the specifications applicable at the time of sale in accordance with TI's standard warranty. Testing and other quality control techniques are used to the extent TI deems necessary to support this warranty. Except where mandated by government requirements, testing of all parameters of each product is not necessarily performed.

TI assumes no liability for applications assistance or customer product design. Customers are responsible for their products and applications using TI components. To minimize the risks associated with customer products and applications, customers should provide adequate design and operating safeguards.

TI does not warrant or represent that any license, either express or implied, is granted under any TI patent right, copyright, mask work right, or other TI intellectual property right relating to any combination, machine, or process in which TI products or services are used. Information published by TI regarding third-party products or services does not constitute a license from TI to use such products or services or a warranty or endorsement thereof. Use of such information may require a license from a third party under the patents or other intellectual property of the third party, or a license from TI under the patents or other intellectual property of TI.

Reproduction of information in TI data books or data sheets is permissible only if reproduction is without alteration and is accompanied by all associated warranties, conditions, limitations, and notices. Reproduction of this information with alteration is an unfair and deceptive business practice. TI is not responsible or liable for such altered documentation.

Resale of TI products or services with statements different from or beyond the parameters stated by TI for that product or service voids all express and any implied warranties for the associated TI product or service and is an unfair and deceptive business practice. TI is not responsible or liable for any such statements.

Following are URLs where you can obtain information on other Texas Instruments products and application solutions:

<b>Products</b>		<b>Applications</b>	
Amplifiers	<a href="http://amplifier.ti.com">amplifier.ti.com</a>	Audio	<a href="http://www.ti.com/audio">www.ti.com/audio</a>
Data Converters	<a href="http://dataconverter.ti.com">dataconverter.ti.com</a>	Automotive	<a href="http://www.ti.com/automotive">www.ti.com/automotive</a>
DSP	<a href="http://dsp.ti.com">dsp.ti.com</a>	Broadband	<a href="http://www.ti.com/broadband">www.ti.com/broadband</a>
Interface	<a href="http://interface.ti.com">interface.ti.com</a>	Digital Control	<a href="http://www.ti.com/digitalcontrol">www.ti.com/digitalcontrol</a>
Logic	<a href="http://logic.ti.com">logic.ti.com</a>	Military	<a href="http://www.ti.com/military">www.ti.com/military</a>
Power Mgmt	<a href="http://power.ti.com">power.ti.com</a>	Optical Networking	<a href="http://www.ti.com/opticalnetwork">www.ti.com/opticalnetwork</a>
Microcontrollers	<a href="http://microcontroller.ti.com">microcontroller.ti.com</a>	Security	<a href="http://www.ti.com/security">www.ti.com/security</a>
		Telephony	<a href="http://www.ti.com/telephony">www.ti.com/telephony</a>
		Video & Imaging	<a href="http://www.ti.com/video">www.ti.com/video</a>
		Wireless	<a href="http://www.ti.com/wireless">www.ti.com/wireless</a>

Mailing Address: Texas Instruments  
Post Office Box 655303 Dallas, Texas 75265