

阅读申明

- 1.本站收集的数据手册和产品资料都来自互联网，版权归原作者所有。如读者和版权方有任何异议请及时告之，我们将妥善解决。
- 2.本站提供的中文数据手册是英文数据手册的中文翻译，其目的是协助用户阅读，该译文无法自动跟随原稿更新，同时也可能存在翻译上的不当。建议读者以英文原稿为参考以便获得更精准的信息。
- 3.本站提供的产品资料，来自厂商的技术支持或者使用者的心得体会等，其内容可能存在描述上的差异，建议读者做出适当判断。
- 4.如需与我们联系，请发邮件到marketing@iczoom.com，主题请标有“数据手册”字样。

Read Statement

1. The datasheets and other product information on the site are all from network reference or other public materials, and the copyright belongs to the original author and original published source. If readers and copyright owners have any objections, please contact us and we will deal with it in a timely manner.
2. The Chinese datasheets provided on the website is a Chinese translation of the English datasheets. Its purpose is for reader's learning exchange only and do not involve commercial purposes. The translation cannot be automatically updated with the original manuscript, and there may also be improper translations. Readers are advised to use the English manuscript as a reference for more accurate information.
3. All product information provided on the website refer to solutions from manufacturers' technical support or users the contents may have differences in description, and readers are advised to take the original article as the standard.
4. If you have any questions, please contact us at marketing@iczoom.com and mark the subject with "Datasheets" .

Prepared		Product Specifications AN7586	Ref No.	A - 1
Checked			Total Page	12
Approved			Page No.	1

Structure	Silicon Monolithic Bipolar IC
Appearance	SIL-7 Pins Plastic Package (Power Type With Fin)
Application	Low Frequency Amplifier
Function	Mono 10W Audio Power Amplifier, with standby circuit and incorporating protection circuits

A	Absolute Maximum Ratings				
No.	Item	Symbol	Ratings	Unit	Note
1	Storage Temperature	Tstg	-55 ~ +150	° C	1
2	Operating Ambient Temperature	Topr	-25 ~ +75	° C	1
3	Operating Ambient Pressure	Popr	$1.013 \times 10^5 \pm 0.61 \times 10^5$ (1.0 ± 0.6)	Pa (atm)	
4	Operating Constant Acceleration	Gopr	9,810 (1,000)	m / s ² (G)	
5	Operating Shock	Sopr	4,900 (500)	m / s ² (G)	
6	Power Supply Voltage	Vcc	35.0	V	
7	Power Supply Current	Icc	2.0	A	
8	Power Dissipation	PD	18.7	W	2

Operating Supply Voltage Range	Vcc	10.0 V ~ 32.0 V
--------------------------------	-----	-----------------

Note : 1) Except these items, all other measurements are taken at Ta = 25 °C.

2) Ta = 75 °C with infinite heat sink.

Eff. Date	Eff. Date	Eff. Date	Eff. Date	
11-Feb-1999				

Prepared		Product Specifications AN7586	Ref No.	A-2
Checked			Total Page	12
Approved			Page No.	2

A	Absolute Maximum Ratings				
No.	Item	Symbol	Ratings	Unit	Note
1	Pin Voltage (Pin 3)	V ₃	-0.3 ~ +3.0	V	

Note) For the above mentioned terminals do not apply a voltage or current that is outside the described range.

Eff. Date	Eff. Date	Eff. Date	Eff. Date	
11-Feb-1999				

Prepared		Product Specifications AN7586	Ref No.	C - 1
Checked			Total Page	12
Approved			Page No.	4

Description of Test Circuits and Test Methods

Test Circuit :

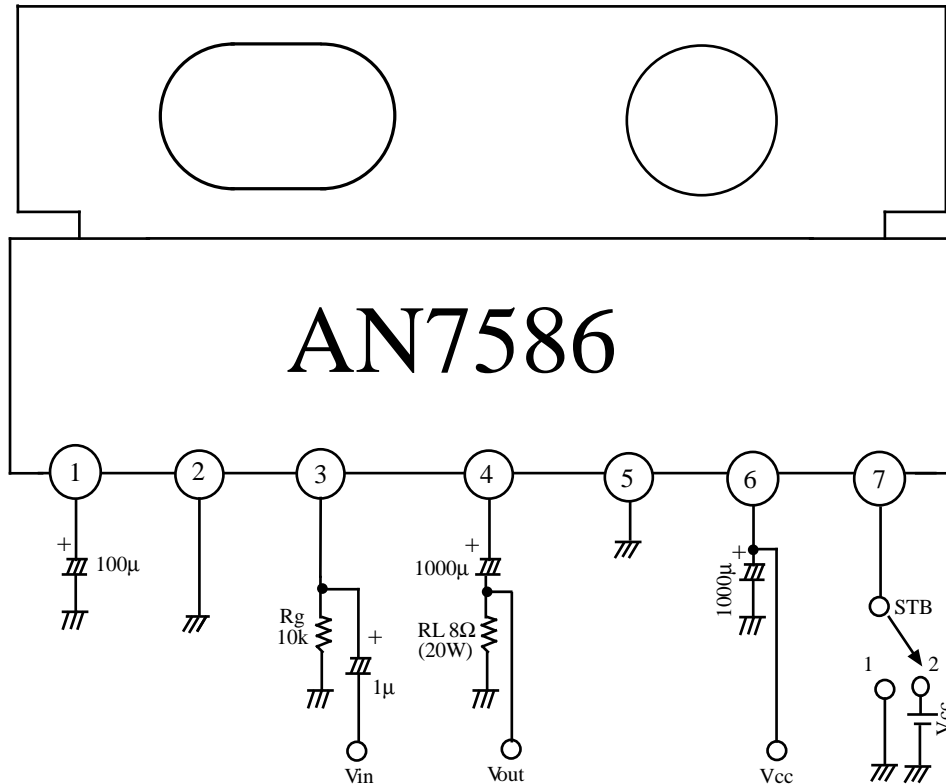

Note:
For ' OPERATIONAL MODE ', connect STB to Vcc.

Eff. Date	Eff. Date	Eff. Date	Eff. Date
11-Feb-1999			

Prepared		Product Specifications AN7586	Ref No.	D - 1
Checked			Total Page	12
Approved			Page No.	5

Circuit Function Block Diagram

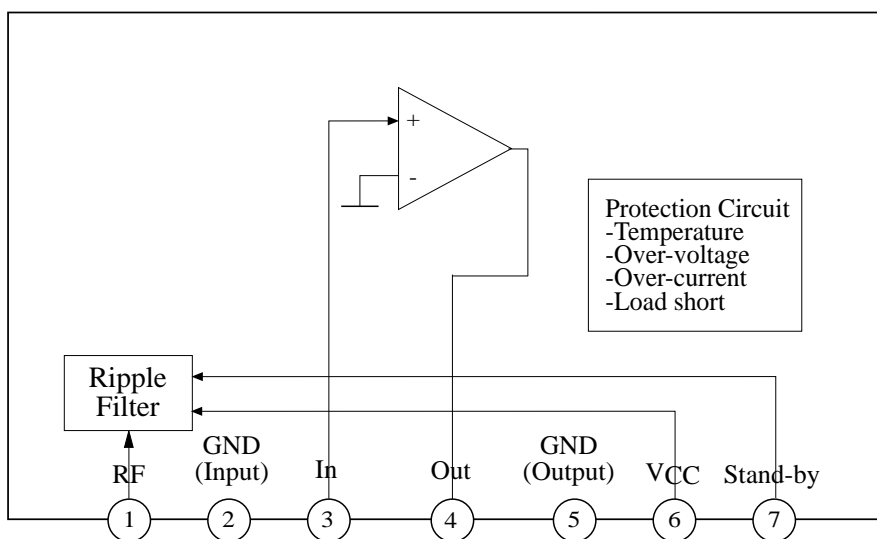

Pin Descriptions

Pin No.	Pin Descriptions	Pin No.	Pin Descriptions
1	Ripple Filter	5	GND (output)
2	GND (input)	6	Vcc
3	Input	7	Standby
4	Output		

Eff. Date	Eff. Date	Eff. Date	Eff. Date
11-Feb-1999			

Prepared		Product Specifications AN7586	Ref No.	E-1
Checked			Total Page	12
Approved			Page No.	6
			Package Name	FP - 7S

Unit : mm

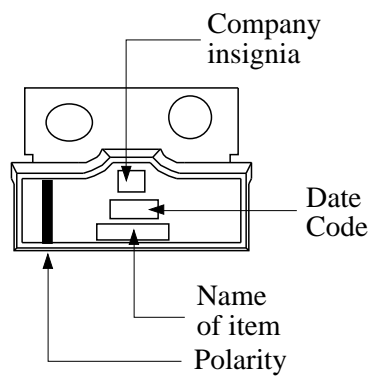
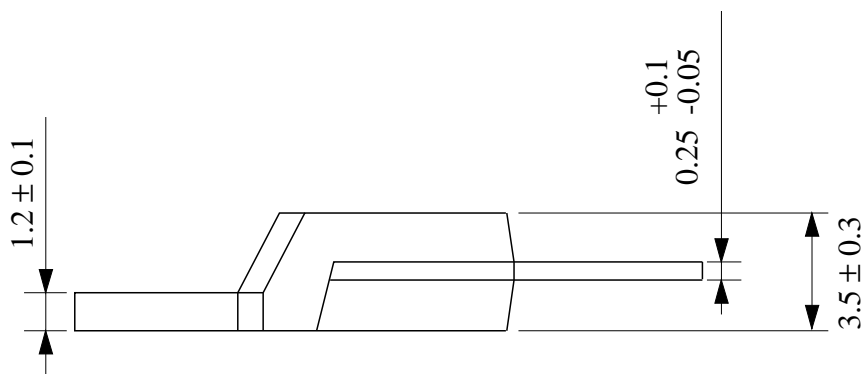
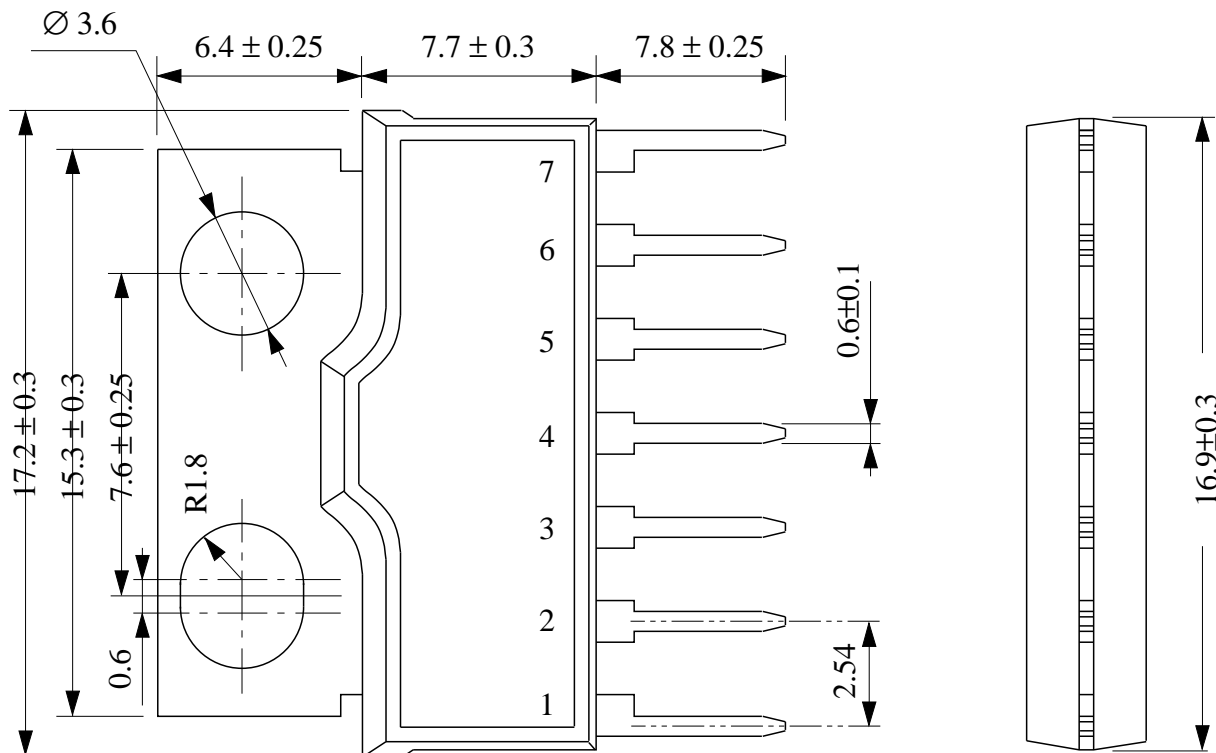

Eff. Date	Eff. Date	Eff. Date	Eff. Date
11-Feb-1999			

Prepared		Product Specifications AN7586	Ref No.	F
Checked			Total Page	12
Approved			Page No.	7

(Structure Description)

Chip surface passivation	SiN,	PSG,	Others ()	①	
Lead frame material	Fe group,	Cu group,	Others ()	②, ⑥	
Inner lead surface process	Ag plating,	Au plating,	Others ()	②	
Outer lead surface process	Solder plating,	Solder dip,	Others ()	⑥	
Chip mounting method	Ag paste,	Au-Si alloy,	Solder,	Others ()	③
Wire bonding method	Thermalsonic bonding,		Others ()	④	
Wire material	Au,	Diameter 38 μm	Others ()	④	
Mold material	Epoxy,		Others ()	⑤	
Molding method	Transfer mold,	Multiplunger mold,	Others ()	⑤	
Heat Fin Material	Fe group,	Cu group,	Others ()	⑦	

Package FP-7S

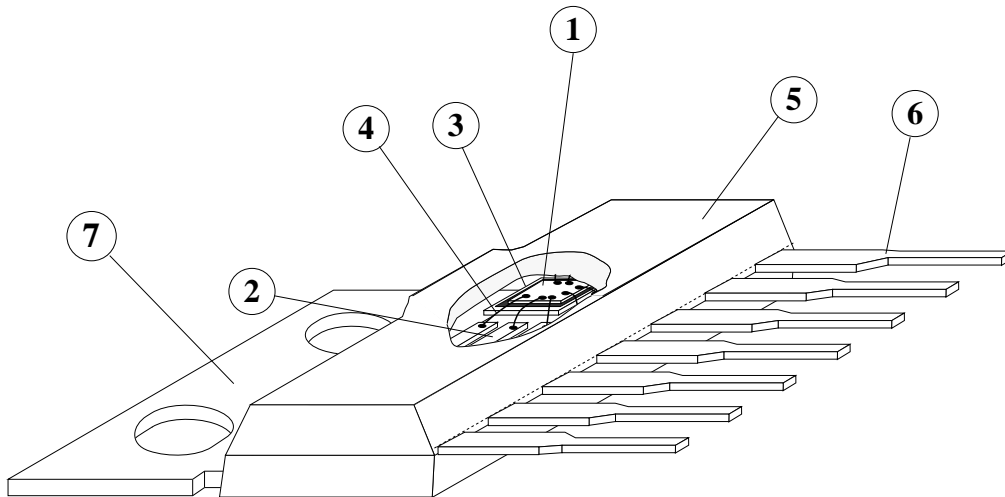

Eff. Date	Eff. Date	Eff. Date	Eff. Date	
11-Feb-1999				

Prepared		Product Specifications AN7586	Ref No.	G - 1
Checked			Total Page	12
Approved			Page No.	8

Application Circuit

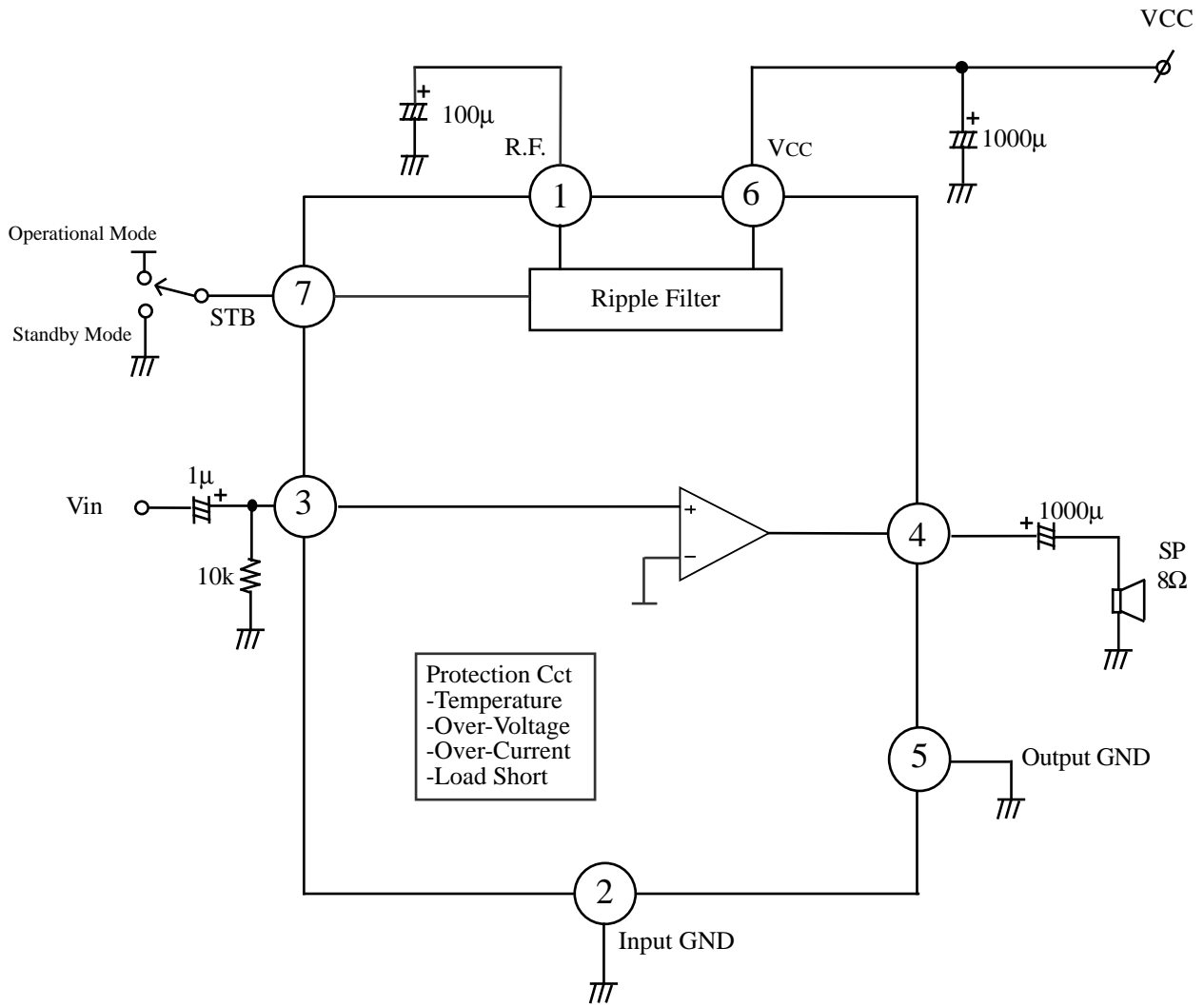

Operational Mode	VCC
Standby Mode	0V

Eff. Date	Eff. Date	Eff. Date	Eff. Date
11-Feb-1999			

Prepared		Product Specifications (Technical Data) AN7586	Ref No.	G - 2
Checked			Total Page	12
Approved			Page No.	9

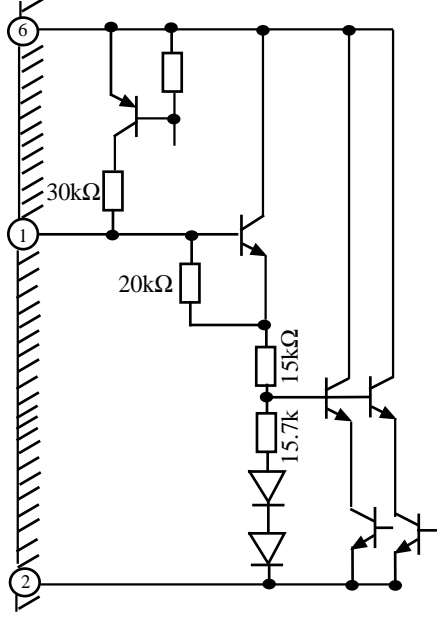
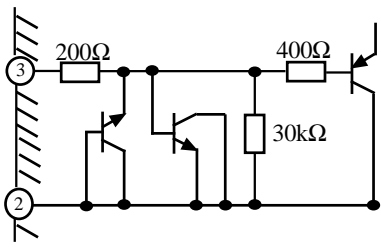
Pin No.	Function	Adjacent Circuitry	Pins Description / Signal	DC Bias (V)
1	Ripple Filter		This is the pin to connect the positive terminal of a ripple filter capacitor.	Vcc-1.5V _{BE}
2	Input GND		Input ground pin.	0V
3	Input		This is the amplifier input pin.	0V

Eff. Date	Eff. Date	Eff. Date	Eff. Date
11-Feb-1999			

Prepared		Product Specifications (Technical Data) AN7586	Ref No.	G - 2
Checked			Total Page	12
Approved			Page No.	10

Pin No.	Function	Adjacent Circuitry	Pins Description / Signal	DC Bias (V)
4	Output		Output pin	$V_{cc}/2$
5	Output Gnd		Output ground.	0V
6	Vcc		This is the power supply pin.	Typ: 26V
7	Standby		Standby control pin. Standby Mode = 0 V Operational Mode = Vcc	

Eff. Date	Eff. Date	Eff. Date	Eff. Date
11-Feb-1999			

Prepared		Product Specifications	Ref No.	G-3
Checked			Total Page	12
Approved			Page No.	11

AN7586

FP-7S Power Dissipation vs. Ambient Temperature

- 1 Infinity Heat Sink : $R_{th(j-c)} = 4 \text{ } ^\circ\text{C/W}$
- 2 No Heat Sink : $R_{th(j-a)} = 53.2 \text{ } ^\circ\text{C/W}$

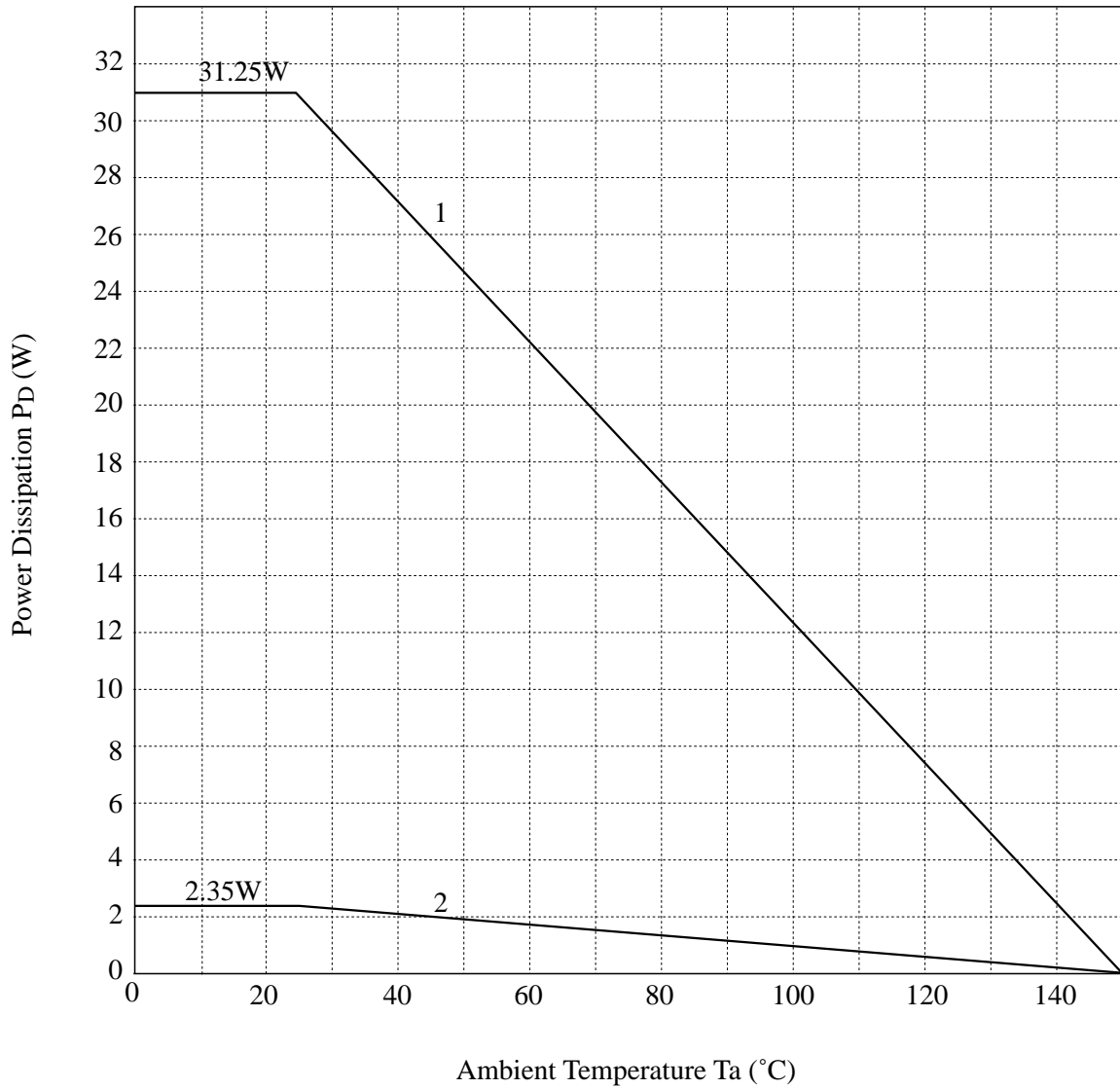

Eff. Date	Eff. Date	Eff. Date	Eff. Date
11-Feb-1999			

Prepared		Product Specifications AN7586	Ref No.	H
Checked			Total Page	12
Approved			Page No.	12

Application's Precautions

- (1) External heatsink is needed when used. External heatsink should be fixed to the chassis.
- (2) Fin of the IC can be connected to GND.
- (3) Please prevent "Output to VCC short", "Output to GND short", "Pin Shift" in direction of Pin 7 and "Reverse Insertion" to avoid damaging the IC.
- (4) The temperature protection circuit will operate at Tj around 150°C. However, if temperature decrease, the protection circuit will automatically be deactivated and resume normal operation.

Eff. Date	Eff. Date	Eff. Date	Eff. Date	
11-Feb-1999				