

## 阅读申明

- 1.本站收集的数据手册和产品资料都来自互联网，版权归原作者所有。如读者和版权方有任何异议请及时告之，我们将妥善解决。
- 2.本站提供的中文数据手册是英文数据手册的中文翻译，其目的是协助用户阅读，该译文无法自动跟随原稿更新，同时也可能存在翻译上的不当。建议读者以英文原稿为参考以便获得更精准的信息。
- 3.本站提供的产品资料，来自厂商的技术支持或者使用者的心得体会等，其内容可能存在描述上的差异，建议读者做出适当判断。
- 4.如需与我们联系，请发邮件到marketing@iczoom.com，主题请标有“数据手册”字样。

## Read Statement

1. The datasheets and other product information on the site are all from network reference or other public materials, and the copyright belongs to the original author and original published source. If readers and copyright owners have any objections, please contact us and we will deal with it in a timely manner.
2. The Chinese datasheets provided on the website is a Chinese translation of the English datasheets. Its purpose is for reader's learning exchange only and do not involve commercial purposes. The translation cannot be automatically updated with the original manuscript, and there may also be improper translations. Readers are advised to use the English manuscript as a reference for more accurate information.
3. All product information provided on the website refer to solutions from manufacturers' technical support or users the contents may have differences in description, and readers are advised to take the original article as the standard.
4. If you have any questions, please contact us at marketing@iczoom.com and mark the subject with "Datasheets" .

---

## HIGH FIDELITY CLASS D AUDIO AMPLIFIER SOLUTION

---

### DESCRIPTION

The ZXCD1010 provides complete control and modulation functions at the heart of a high efficiency high performance Class D switching audio amplifier solution. In combination with matched output magnetics and Zetex HDMOS MOSFET devices, the ZXCD1010 provides a high performance Class D audio amplifier with all the inherent benefits of Class D.

The ZXCD1010 is an enhanced version of the ZXCD1000. The timing resistor for the oscillator is taken off the chip enabling improved oscillator frequency matching device to device.

The ZXCD1010 solution uses proprietary circuitry and magnetic technology to realise the true benefits of Class D without the traditional drawback of poor distortion performance. The combination of circuit design, magnetic component choice and layout are essential to realising these benefits.

### FEATURES

- 90% efficiency
- External  $R_{OSC}$   $C_{OSC}$  for improved accuracy
- 4 / 8  $\Omega$  drive capability
- Noise Floor -115dB for solution
- Flat response 20Hz - 20kHz
- High gate drive capability ( 2200pF)
- Very low THD + N 0.2% typical of full power up to 90% ( for the solution)
- Complete absence of crossover artifacts
- OSC output available for sync in multi-channel applications
- Available in a 16 pin exposed pad QSOP package
- Refer to ZXCD1000 data sheet for typical characteristics and applications indormation

The ZXCD1010 reference designs give output powers up to 100W rms with typical open loop (no feedback) distortions of less than 0.2% THD + N over the entire audio frequency range at 90% full output power. This gives an extremely linear system. The addition of a minimum amount of feedback (10dB) further reduces distortion figures to give < 0.1 % THD + N typical at 1kHz.

From an acoustic point of view, even more important than the figures above, the residual distortion is almost totally free of any crossover artifacts. This allows the ZXCD1010 to be used in true hi-fi applications. This lack of crossover distortion, sets the ZXCD1010 solutions quite apart from most other presently available solutions.

### APPLICATIONS

- DVD receivers
- Automotive audio systems
- Home Theatre
- Multimedia
- Wireless speakers
- Portable audio
- Sub woofer systems
- Public Address systems

**Distortion v Power (8 $\Omega$  open loop at 1kHz.)**

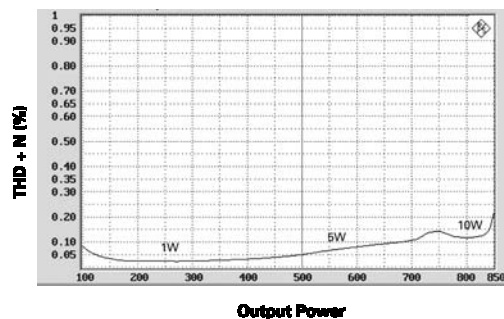

# ZXCD1010

## ABSOLUTE MAXIMUM RATINGS

Terminal Voltage with respect to G<sub>ND</sub>

V <sub>CC</sub>	20V
Power Dissipation	1W
Package Thermal Resistance (θ <sub>ja</sub> )	54°C/W
Operating Temperature Range	-40°C to 70°C
Maximum Junction Temperature	125°C
Storage Temperature Range	-50°C to 85°C

Stresses beyond those listed under "Absolute Maximum Ratings" may cause permanent damage to the device. These are stress ratings only, and functional operation of the device at these or any other conditions beyond those indicated in the operational sections of the specifications is not implied. Exposure to absolute maximum conditions for extended periods may affect device reliability.

## ELECTRICAL CHARACTERISTICS

TEST CONDITIONS (unless otherwise stated) V<sub>CC</sub> = 16V, T<sub>A</sub> = 25°C

SYMBOL	PARAMETER	CONDITIONS	LIMITS			UNITS
			MIN	TYP	MAX	
V <sub>CC</sub>	Operating Voltage Range		12	16	18	V
I <sub>ss</sub>	Operating Quiescent Current	V <sub>CC</sub> = 12V V <sub>CC</sub> = 18V, 16V			45 50	mA mA
F <sub>osc</sub>	Switching Frequency	C <sub>OSC</sub> = 330pF, R <sub>OSC</sub> = 31k5	173	192	211	kHz
F <sub>osc(tol)</sub>	Frequency Tolerance	C <sub>OSC</sub> = 330pF, R <sub>OSC</sub> = 31k5			+/-10	%
V <sub>ol</sub> OutA/B	Low level output voltage	No load			100	mV
V <sub>oh</sub> OutA/B	High level output voltage	No load	7.5			V
T <sub>Drive</sub>	Output Drive Capability (OUT A / B Rise/Fall)	Load Capacitance = 2200pF		50		ns
5V5tol	Internal Rail Tolerance	1μF Decoupling	5.16	5.5	5.77	V
9VA/Btol	Internal Rail Tolerance	1μF Decoupling	8.32	8.75	9.18	V
Audio A / B	Input Impedence		1.35k	1.8k	2.3k	Ω
Triangle A / B	Input Impedence		1.35k	1.8k	2.3k	Ω
Audio A / B	Bias Level		2.95	3.1	3.25	V
Triangle A / B	Bias Level		2.95	3.1	3.25	V
Osc A / B	Amplitude		0.89	1.05	1.2	V

# ZXCD1010

Pin number	Pin Name	Pin Description
1	Audio A	Audio Input for Channel A
2	Triangle A	Triangle Input for Channel A
3	Osc A	Triangle Output
4	R <sub>OSC</sub>	External timing resistor node (to set the switching frequency)
5	C <sub>OSC</sub>	External timing capacitor node (to set the switching frequency)
6	Osc B	Triangle Output (for slave ZXCD1010 in stereo application)
7	Triangle B	Triangle Input for Channel B
8	Audio B	Audio Input for Channel B
9	Gnd	Small Signal GND
10	OUT B	Channel B PWM Output to drive external Bridge MOSFETs
11	Gnd2	Power GND (for Output Drivers)
12	9VB	Internal Supply Rail (Decouple with 1 $\mu$ F Cap)
13	VCC	Input Supply Pin (Max = 18V)
14	9VA	Internal Supply Rail (Decouple with 1 $\mu$ F Cap).
15	OUT A	Channel A PWM Output to drive external Bridge MOSFETs
16	5V5	Internal Supply Rail (Decouple with 1 $\mu$ F Cap)

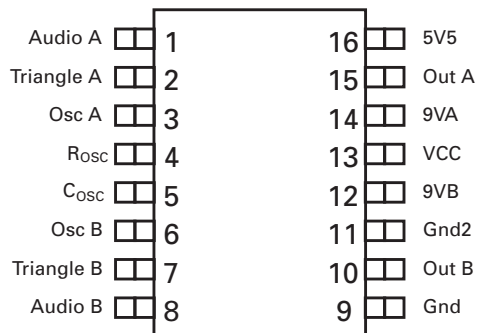

**Figure 1**  
Pin Connection Diagram

# ZXCD1010

## ZXCD1010 Class D controller IC

A functional block diagram of the ZXCD1010 is shown in Figure 2. The on chip series regulators drop the external V<sub>CC</sub> supply (12V-18V) to the approximate 9V (9VA/9VB) and 5.5V (5V5) supplies required by the internal circuitry.

A triangular waveform is generated on chip and is brought out at the OscA and OscB outputs. The frequency of this is set (to ~200kHz) by an external capacitor (C<sub>osc</sub>) and resistor (R<sub>osc</sub>). The triangular waveform must be externally AC coupled back into the ZXCD1010 at the TriangleA and TriangleB inputs.

AC coupling ensures symmetrical operation resulting in minimal system DC offsets. TriangleA is connected to one of the inputs of a comparator and TriangleB is connected to one of the inputs of a second comparator. The other inputs of these two comparators are connected to the AudioA and AudioB inputs, which are anti-phase signals externally derived from the audio input. The triangular wave is an order higher in frequency than the audio input (max 20kHz). The outputs of the comparators toggle every time the TriangleA/B and the (relatively slow) AudioA/B signals cross.

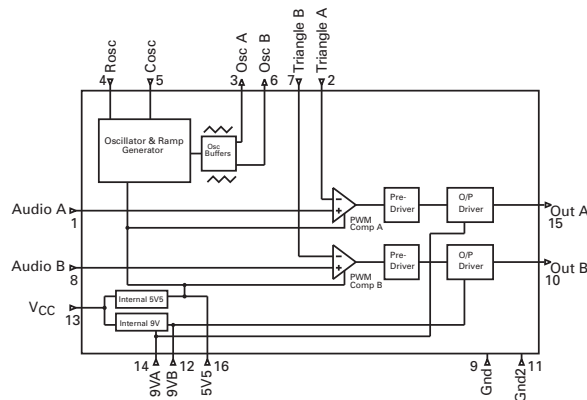

**Figure 2**  
Functional Block Diagram

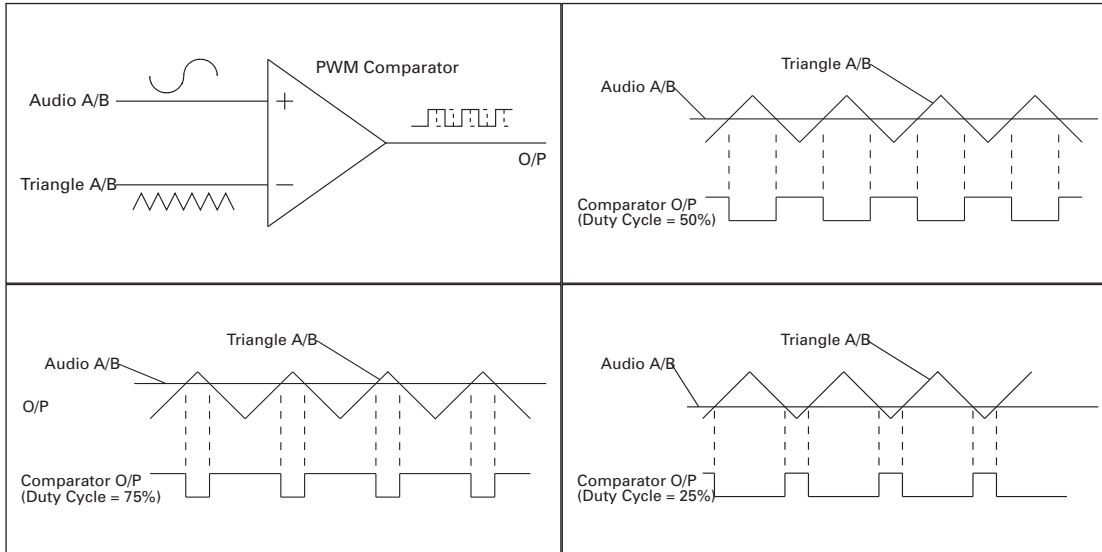

**Figures 3a,3b,3c and 3d**  
The audio input Pulse Width Modulates the comparator output

With no audio input signal applied, the AudioA/B inputs are biased at the mid-point of the triangular wave, and the duty cycle at the output of the comparators is nominally 50%. As the AudioA/B signal ascends towards the peak level, the crossing points with the (higher frequency) triangular wave also ascend. The comparator monitoring these signals exhibits a corresponding increase in output duty cycle. Similarly, as the AudioA/B signal descends, the duty cycle is correspondingly reduced. Thus the audio input Pulse Width Modulates the comparator outputs. This principle is illustrated in Figures 3a, b, c and d. The comparator outputs are buffered and used to drive the OutA and OutB outputs. These in turn drive the speaker load (with the audio information contained in the PWM signal) via the off chip output bridge and single stage L-C filter network.

The ramp amplitude is approximately 1V. The AudioA, AudioB, TriangleA and TriangleB inputs are internally biased to a DC voltage of approximately  $V_{CC}/5$ . The mid - point DC level of the OscA and OscB triangular outputs is around 2V. The triangular wave at the Cosc pin traverses between about 2.7V and 3.8V and the dist pin exhibits a roughly square wave from about 1.4V to 2V. (The above voltages may vary in practice and are included for guidance only).

# ZXCD1010

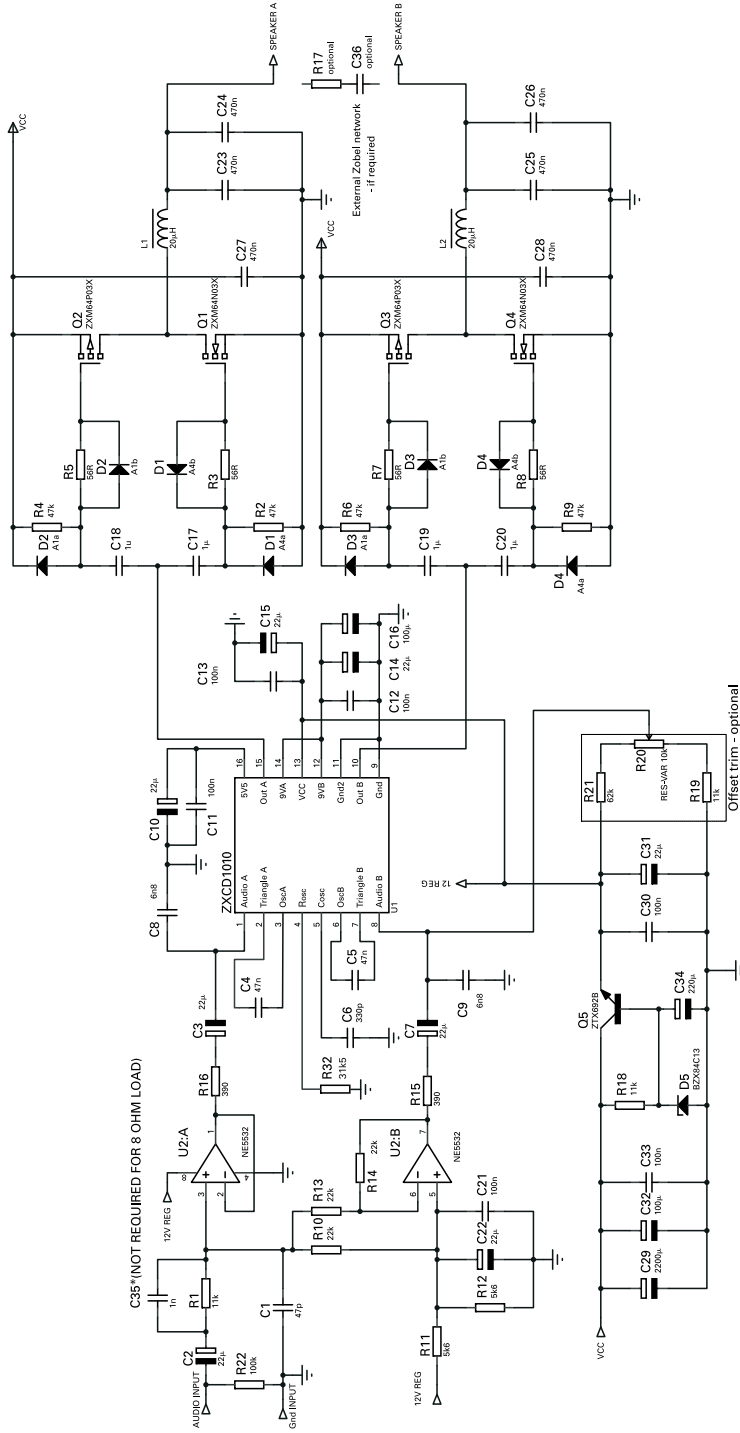

**Figure 4**  
Zetex Class D 25W Mono Open Loop Solution

# ZXCD1010

## Class D 25W Mono Open Loop (Bridge Tied Load - BTL) Solution – Circuit Description

Proprietary circuit design and high quality magnetics are necessary to yield the high THD performance specified. Deviation from the Zetex recommended solution could significantly degrade performance.

The speaker is connected as a Bridge Tied Load (BTL). This means that both sides of the speaker are driven from the output bridge and therefore neither side of the speaker connects to ground. This allows maximum power to be delivered to the load, from a given supply voltage. The supply voltage for this solution is nominally 16V for 25W into a 4Ω load.

A schematic diagram for the solution is shown in Figure 4. The audio input is AC coupled and applied to a low pass filter and a phase splitter built around the NE5532 dual op-amp. One of these op-amps is configured as a voltage follower and the other as a X1 inverting amplifier. This produces in phase and inverted signals for application to the ZXCD1010. The op-amp outputs are AC coupled into the ZXCD1010 Audio A and Audio B inputs via simple R-C low pass filters (R16/C3 and R15/C7). The op-amps are biased to a DC level of approximately 6V by R11 and R12.

The Pulse Width Modulated (PWM) outputs, OutA and OutB, which contain the audio information, are AC coupled and DC restored before driving the Zetex ZXM64P03X and ZXM64N03X PMOS and NMOS output bridge FET's. AC coupling is via C17, C18, C19 and C20. DC restoration is provided by the D2(A1a)/R4, D1(A4a)/R2 and D3(A1a)/R6, D4(A4a)/R9 components. This technique allows the output stage supply voltage to be higher than the high level of the OutA and OutB outputs (approximately 8.5V), whilst still supplying almost the full output voltage swing to the gates of the bridge FET's (thereby ensuring good turn on). This can be exploited to yield higher power solutions with higher supply voltages – this is discussed later.

The resistor/diode combinations (R5/D2(A16b), R3/D1(A4b), R7/D3(A1b) and R8/D4(A4b)) in series with the bridge FET gates, assist in controlling the switching of the bridge FET's. This design minimises shoot through currents whilst still achieving the low distortion characteristics of the system.

The purpose of the special inductors in conjunction with the output capacitors C23, C24, C25 and C26 is to low pass filter the high frequency switching PWM signal that comes from the bridge. Thus the lower frequency audio signal is recovered and is available at the speakerA and speakerB outputs across which the speaker should be connected. Zetex can offer advice on suitable source for the specialist magnetics.

The optional components R17 and C3 form a Zobel network. The applicability of these depends upon the application and speaker characteristics. Suggested values are 47nF and 10 ohms

### Efficiency

Figure 5 shows the measured efficiency of the Zetex solution at various power levels into both 4Ω and 8Ω loads. As a comparison, typical efficiency is plotted for a class A-B amplifier. They clearly demonstrate the major efficiency benefits available from the Zetex class D solution.

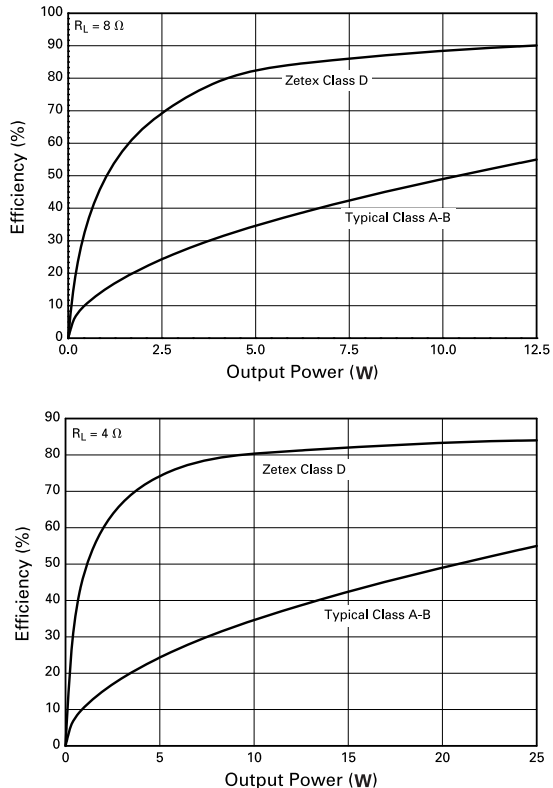

Figure 5 Output Stage Efficiency v Power with 4Ω and 8Ω loads



# ZXCD1010

## Other Solutions - Stereo and Higher Powers

### STEREO

It is possible to duplicate the above solution to give a 2 channel stereo solution. However if the oscillator frequencies are not locked together, a beat can occur which is acoustically audible. This is undesirable. A stereo solution which avoids this problem can be achieved by synchronising the operating frequencies of both ZXCD1010's class D controller IC's, by slaving one device from the other. This is illustrated in Figure 6.

Great care must be taken when linking the triangle from the master to the slave. Any pickup can cause slicing errors and result in increased distortion. The best connection method is to run two tracks, side by side, from the master to the slave. One of these tracks would be the triangle itself, and the other would be the direct local ground linking the master pin 9 ground to the slave pin 9 ground.

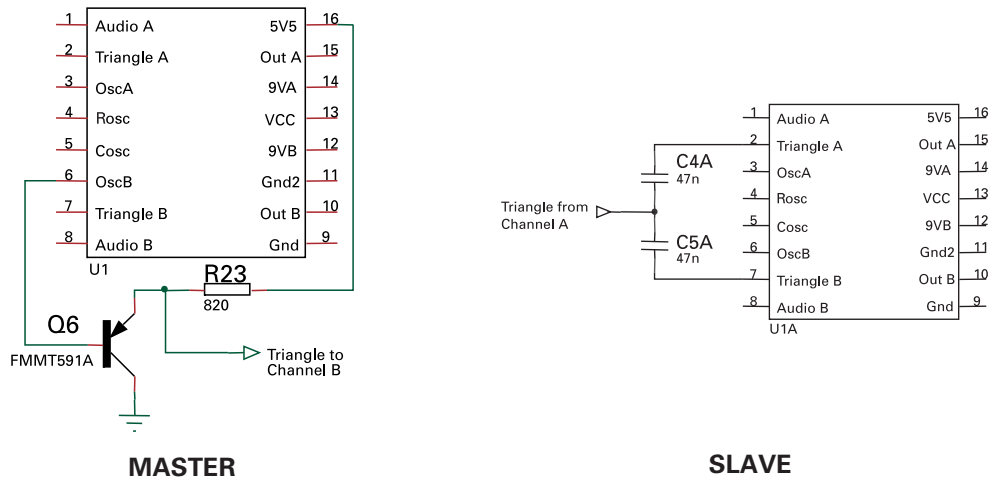

**Figure 6**  
Frequency synchronisation for stereo applications

# ZXCD1010

## Higher Power Solutions

With some modifications the applications solutions can be extended to give output power up to 100W. The main differences being the supply voltage, the TO220 MOSFETs (ZXM64N035L3 and ZXM64P035L3), and the output magnetics. The magnetics for 100W are necessarily larger than required for 25W in order to handle the higher load currents. For 100W operation the supply voltage to the circuit is nominally 35V with a 4 $\Omega$  load.

The ZXCD1010 class D controller IC is inherently capable of driving even higher power solutions, with the appropriate external circuitry. However the maximum supply voltage to the ZXCD1010 class D controller IC is 18V so the higher supply voltages must therefore be dropped. Also due consideration must be given to the ZXCD1010 output drive levels and the characteristics of the bridge MOSFET's. The latter must be sufficiently enhanced by the OutA and OutB outputs to ensure the filter and load network is driven properly. If the gate drive of the ZXCD1010 is too low for the chosen MOSFET then the OUTA and OUTB signal must be buffered using an appropriate MOSFET driver circuit. Additionally, suitable magnetics are essential to achieve good THD performance.

## Package details

The ZXCD1010 is available in a 16 pin exposed pad QSOP package. The exposed pad on the underside of the package should be soldered down to an area of copper on the PCB, to function as a heatsink. The PCB should have plated through vias to the underside of the board, again connecting to an area of copper.

# ZXCD1010

## ZXCD1010 Solution performance figures

Typical performance graphs for the Zetex 25W open loop solution are shown here for both 4 and 8Ω loads. These graphs further demonstrate the true high fidelity performance achieved by the Zetex solutions.

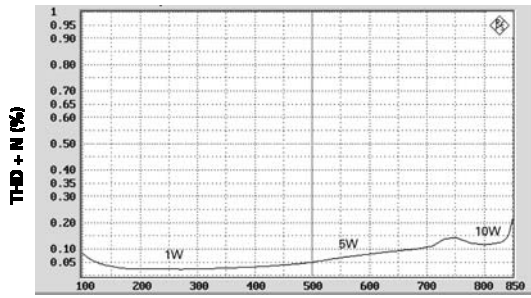

Output Power

THD v Power into 8Ω at 1kHz

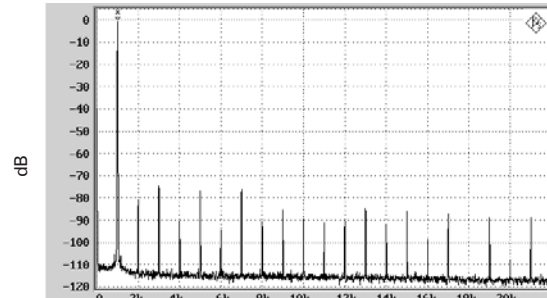

f(Hz)

FFT of distortion and noise floor at 1W (8Ω load)

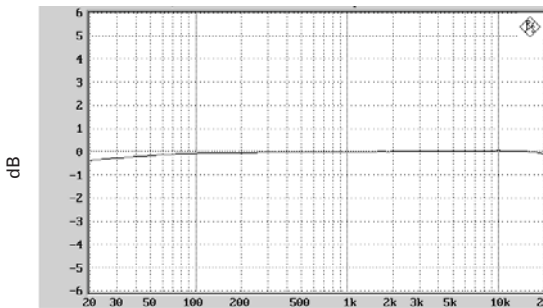

f(Hz)

Frequency response (8Ω load)

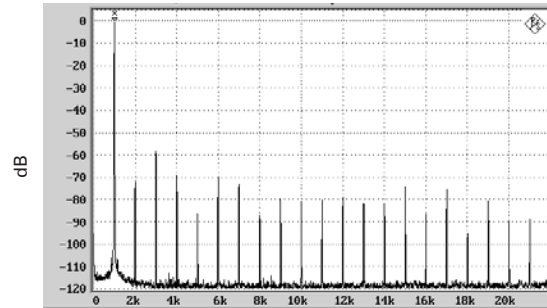

f(Hz)

FFT of distortion and noise floor at 10W (8Ω load)

# ZXCD1010

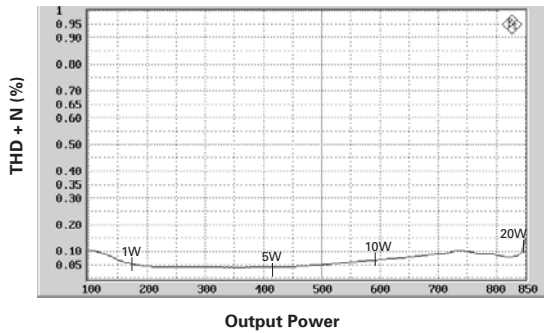

THD v Power into 4Ω at 1kHz

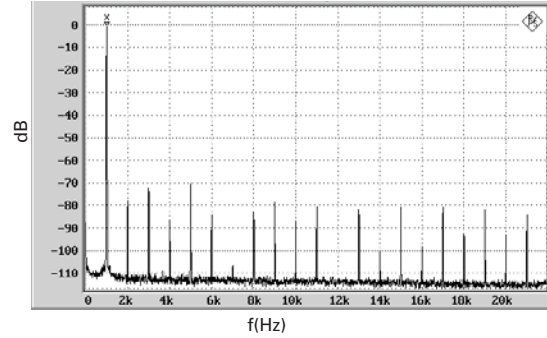

FFT of distortion and noise floor at 1W (4Ω load)

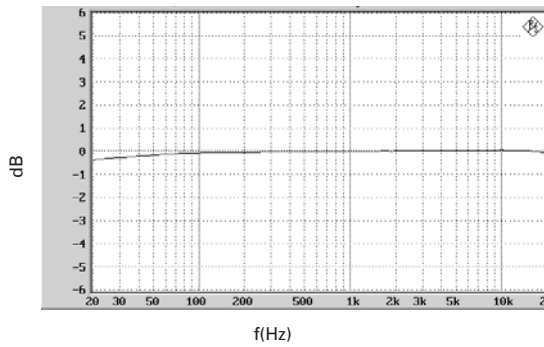

Frequency response (4Ω load)

Note roll off.  
This can be corrected by using an alternative values for output filter components.

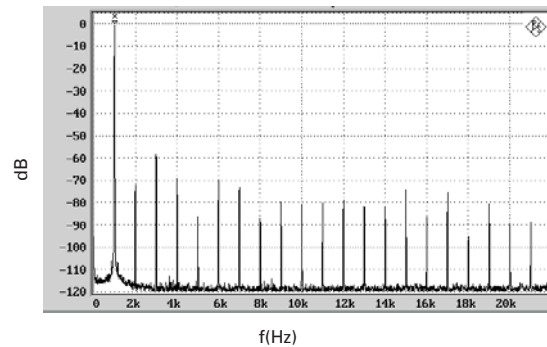

FFT of distortion and noise floor at 20W (4Ω load)

# ZXCD1010

## Definitions

### Product change

Zetex Semiconductors reserves the right to alter, without notice, specifications, design, price or conditions of supply of any product or service. Customers are solely responsible for obtaining the latest relevant information before placing orders.

### Applications disclaimer

The circuits in this design/application note are offered as design ideas. It is the responsibility of the user to ensure that the circuit is fit for the user's application and meets with the user's requirements. No representation or warranty is given and no liability whatsoever is assumed by Zetex with respect to the accuracy or use of such information, or infringement of patents or other intellectual property rights arising from such use or otherwise. Zetex does not assume any legal responsibility or will not be held legally liable (whether in contract, tort (including negligence), breach of statutory duty, restriction or otherwise) for any damages, loss of profit, business, contract, opportunity or consequential loss in the use of these circuit applications, under any circumstances.

### Life support

Zetex products are specifically not authorized for use as critical components in life support devices or systems without the express written approval of the Chief Executive Officer of Zetex Semiconductors plc. As used herein:

A. Life support devices or systems are devices or systems which:

1. are intended to implant into the body  
or
2. support or sustain life and whose failure to perform when properly used in accordance with instructions  
for use provided in the labeling can be reasonably expected to result in significant injury to the user.

B. A critical component is any component in a life support device or system whose failure to perform can be reasonably expected to cause the failure of the life support device or to affect its safety or effectiveness.

### Reproduction

The product specifications contained in this publication are issued to provide outline information only which (unless agreed by the company in writing) may not be used, applied or reproduced for any purpose or form part of any order or contract or be regarded as a representation relating to the products or services concerned.

### Terms and Conditions

All products are sold subjects to Zetex' terms and conditions of sale, and this disclaimer (save in the event of a conflict between the two when the terms of the contract shall prevail) according to region, supplied at the time of order acknowledgement.

For the latest information on technology, delivery terms and conditions and prices, please contact your nearest Zetex sales office.

### Quality of product

Zetex is an ISO 9001 and TS16949 certified semiconductor manufacturer.

To ensure quality of service and products we strongly advise the purchase of parts directly from Zetex Semiconductors or one of our regionally authorized distributors. For a complete listing of authorized distributors please visit: [www.zetex.com/salesnetwork](http://www.zetex.com/salesnetwork)

Zetex Semiconductors does not warrant or accept any liability whatsoever in respect of any parts purchased through unauthorized sales channels.

### ESD (Electrostatic discharge)

Semiconductor devices are susceptible to damage by ESD. Suitable precautions should be taken when handling and transporting devices. The possible damage to devices depends on the circumstances of the handling and transporting, and the nature of the device. The extent of damage can vary from immediate functional or parametric malfunction to degradation of function or performance in use over time. Devices suspected of being affected should be replaced.

### Green compliance

Zetex Semiconductors is committed to environmental excellence in all aspects of its operations which includes meeting or exceeding regulatory requirements with respect to the use of hazardous substances. Numerous successful programs have been implemented to reduce the use of hazardous substances and/or emissions.

All Zetex components are compliant with the RoHS directive, and through this it is supporting its customers in their compliance with WEEE and ELV directives.

### Product status key:

"Preview"Future device intended for production at some point. Samples may be available

"Active"Product status recommended for new designs

"Last time buy (LTB)"Device will be discontinued and last time buy period and delivery is in effect

"Not recommended for new designs"Device is still in production to support existing designs and production

"Obsolete"Production has been discontinued

Datasheet status key:

"Draft version" This term denotes a very early datasheet version and contains highly provisional information, which may change in any manner without notice.

"Provisional version" This term denotes a pre-release datasheet. It provides a clear indication of anticipated performance. However, changes to the test conditions and specifications may occur, at any time and without notice.

"Issue" This term denotes an issued datasheet containing finalized specifications. However, changes to specifications may occur, at any time and without notice.



ISSUE 4 - AUGUST 2007

# ZXCD1010

## PACKAGE DIMENSIONS

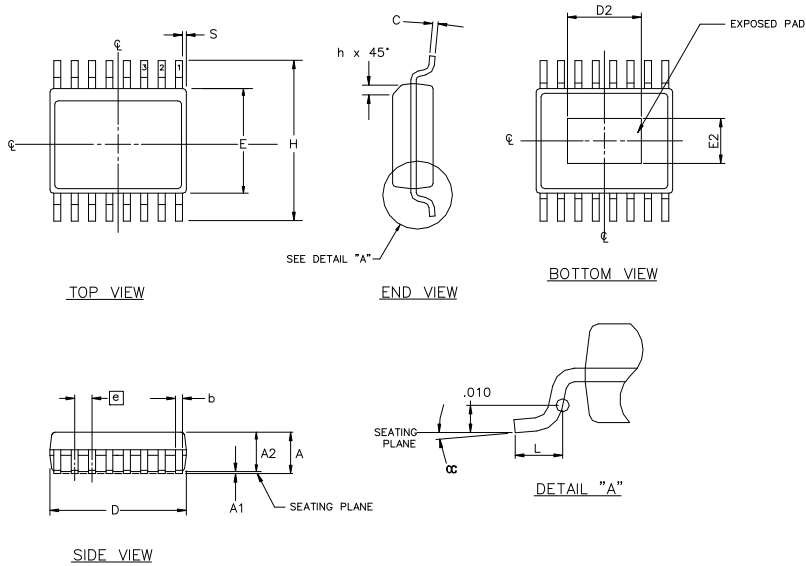

Controlling dimensions are in inches. Approximate conversions are given in millimeters

## PACKAGE DIMENSIONS

DIM	Inches		Millimeters		DIM	Inches		Millimeters	
	Min	Max	Min	Max		Min	Max	Min	Max
A	0.058	0.066	1.473	1.676	E2	0.062	0.070	1.575	1.778
A1	0.001	0.005	0.025	0.127	e	0.025 BSC		0.635 BSC	
A2	0.055	0.061	1.397	1.549	H	0.228	0.244	5.791	6.198
b	0.008	0.012	0.203	0.305	h	0.010	0.016	0.254	0.406
c	0.007	0.010	0.178	0.254	L	0.016	0.035	0.406	0.889
D	0.189	0.196	4.801	4.978	S	0.002	0.007	0.051	0.178
D2	0.102	0.110	2.591	2.794	$\alpha$	0°	8°	0°	8°

## ORDERING INFORMATION

Device	Description	Package	T&R Suffix
ZXCD1010EQ16	Class D modulator	QSOP16*	TA, TC

Information on Zetex reference designs, MOSFETs and demonstration boards can be obtain by contacting Zetex applications or by visiting [www.zetex.com/audio](http://www.zetex.com/audio)

\*This package features an exposed pad which must be soldered down.