

## 阅读申明

- 1.本站收集的数据手册和产品资料都来自互联网，版权归原作者所有。如读者和版权方有任何异议请及时告之，我们将妥善解决。
- 2.本站提供的中文数据手册是英文数据手册的中文翻译，其目的是协助用户阅读，该译文无法自动跟随原稿更新，同时也可能存在翻译上的不当。建议读者以英文原稿为参考以便获得更精准的信息。
- 3.本站提供的产品资料，来自厂商的技术支持或者使用者的心得体会等，其内容可能存在描述上的差异，建议读者做出适当判断。
- 4.如需与我们联系，请发邮件到marketing@iczoom.com，主题请标有“数据手册”字样。

## Read Statement

1. The datasheets and other product information on the site are all from network reference or other public materials, and the copyright belongs to the original author and original published source. If readers and copyright owners have any objections, please contact us and we will deal with it in a timely manner.
2. The Chinese datasheets provided on the website is a Chinese translation of the English datasheets. Its purpose is for reader's learning exchange only and do not involve commercial purposes. The translation cannot be automatically updated with the original manuscript, and there may also be improper translations. Readers are advised to use the English manuscript as a reference for more accurate information.
3. All product information provided on the website refer to solutions from manufacturers' technical support or users the contents may have differences in description, and readers are advised to take the original article as the standard.
4. If you have any questions, please contact us at marketing@iczoom.com and mark the subject with "Datasheets" .

# DATA SHEET

## **TDA1557Q**

**2 x 22 W BTL stereo car radio  
power amplifier with speaker  
protection**

Product specification  
File under Integrated Circuits, IC01

May 1992

## 2 x 22 W BTL stereo car radio power amplifier with speaker protection

### TDA1557Q

#### FEATURES

- Requires very few external components
- High output power
- Low offset voltage at output
- Fixed gain
- Good ripple rejection
- Mute/stand-by switch
- Load dump protection
- AC and DC short-circuit-safe to ground and  $V_P$
- Thermally protected
- Reverse polarity safe
- Capability to handle high energy on outputs ( $V_P = 0$ )

- Protected against electrostatic discharge
- No switch-on/switch-off plop
- Flexible leads
- Low thermal resistance.

#### GENERAL DESCRIPTION

The TDA1557Q is a monolithic integrated class-B output amplifier in a 13-lead single-in-line (SIL) plastic power package. The device contains  $2 \times 22$  W amplifiers in BTL configuration and has been primarily developed for car radio applications.

#### QUICK REFERENCE DATA

SYMBOL	PARAMETER	CONDITIONS	MIN.	TYP.	MAX.	UNIT
$V_P$	positive supply voltage range	operating	6.0	14.4	18	V
		non-operating	–	–	30	V
		load dump	–	–	45	V
IORM	repetitive peak output current		–	–	4	A
$I_{tot}$	total quiescent current		–	80	–	mA
$I_{sb}$	stand-by current		–	0.1	100	$\mu$ A
$I_{sw}$	switch-on current		–	–	60	$\mu$ A
$ Z_i $	input impedance		25	–	–	k $\Omega$
$T_{XTAL}$	crystal temperature		–	–	+150	$^{\circ}$ C

#### Stereo application

$P_O$	output power	THD = 10%; 4 $\Omega$	–	22	–	W
SVRR	supply voltage ripple rejection	$R_S = 0$ ; $f = 100$ Hz to 10 kHz	45	–	–	dB
$ \Delta V_O $	DC output offset voltage		–	–	250	mV
$\alpha$	channel separation		40	–	–	dB
$ \Delta G_v $	channel unbalance		–	–	1	dB
$G_v$	closed loop voltage gain		45	46	47	dB

#### ORDERING INFORMATION

EXTENDED TYPE NUMBER	PACKAGE			
	PINS	PIN POSITION	MATERIAL	CODE
TDA1557Q	13	DIL	plastic	SOT141R

#### Note

1. SOT141-6; 1996 August 23.

2 x 22 W BTL stereo car radio power amplifier with speaker protection

TDA1557Q

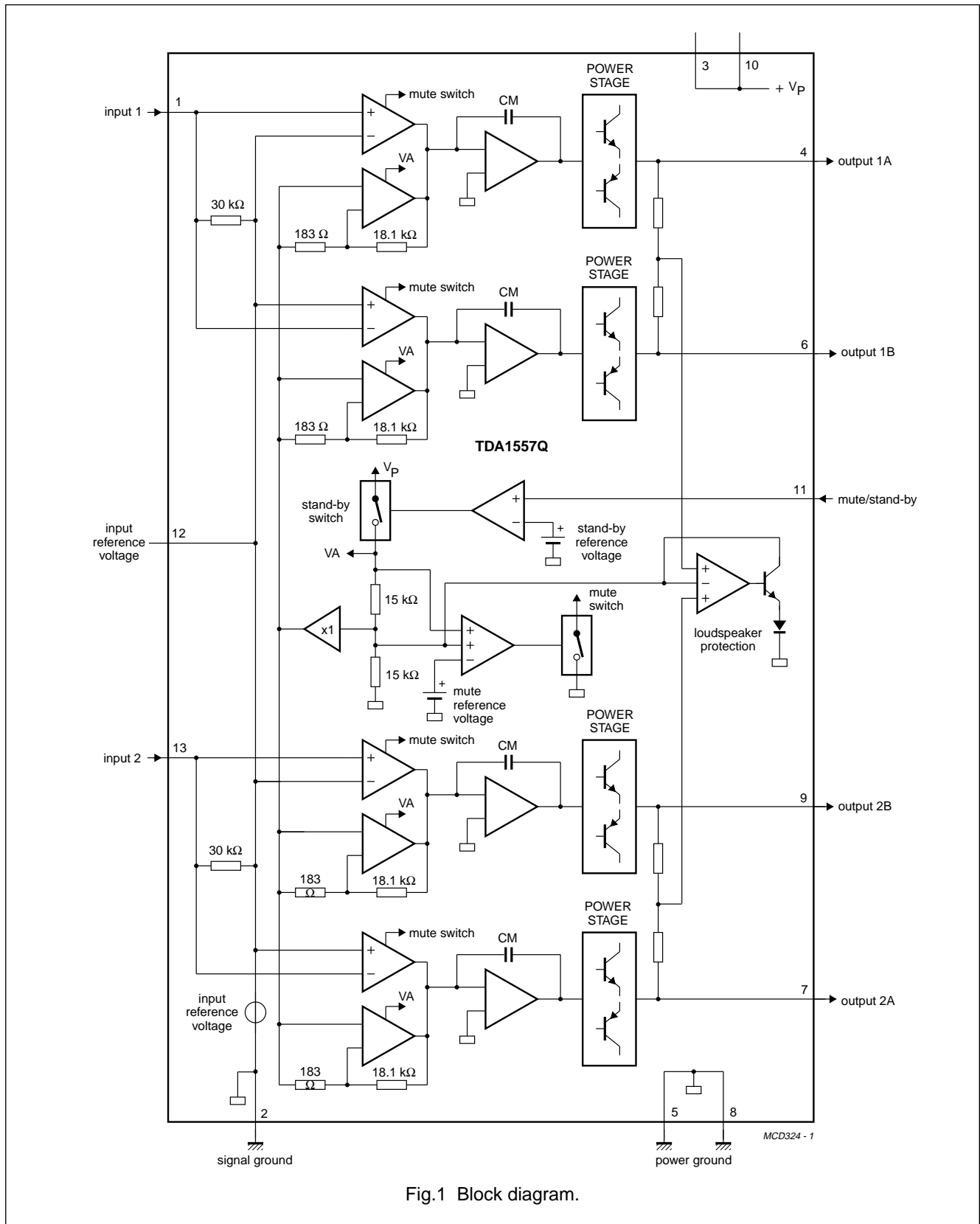

Fig.1 Block diagram.

# 2 x 22 W BTL stereo car radio power amplifier with speaker protection

## TDA1557Q

### PINNING

SYMBOL	PIN	DESCRIPTION
INP1	1	input 1
GND1	2	ground (signal)
V <sub>P1</sub>	3	supply voltage 1
OUT1A	4	output 1A
GND	5	power ground 1
OUT1B	6	output 1B
OUT2A	7	output 2A
GND	8	power ground 2
OUT2B	9	output 2B
V <sub>P2</sub>	10	supply voltage 2
M/SS	11	mute/stand-by switch
V <sub>ref</sub>	12	input reference voltage
INP2	13	input 2

### FUNCTIONAL DESCRIPTION

The TDA1557Q contains two identical amplifiers with differential input stages, and can be used for bridge applications. The gain of each amplifier is fixed at 46 dB. Special features of this device are:

- a. mute/stand-by switch
  - low stand-by current
  - low mute/stand-by switching current (low cost supply switch)
  - mute facility
- b. loudspeaker protection
  - when a short circuit to ground is made, which forces a DC voltage of  $\geq 1$  V across the loudspeaker, a built-in protection circuit becomes active and limits the DC voltage across the loudspeaker to  $\leq 1$  V
- c. the harmonic distortion at low frequencies can be decreased by connecting two diodes to ground at pin 12.

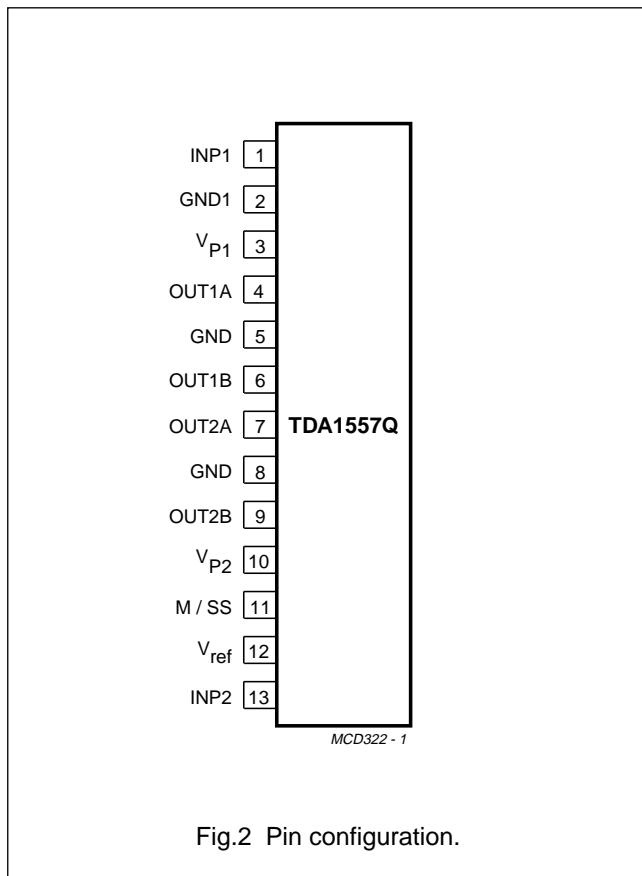

# 2 x 22 W BTL stereo car radio power amplifier with speaker protection

TDA1557Q

## LIMITING VALUES

In accordance with the Absolute maximum System (IEC 134).

SYMBOL	PARAMETER	CONDITIONS	MIN.	MAX.	UNIT
V <sub>P</sub>	positive supply voltage	operating	–	18	V
		non-operating	–	30	V
		load dump protected; during 50 ms; rise time ≥ 2.5 ms	–	45	V
V <sub>PSC</sub>	AC and DC short-circuit safe voltage		–	18	V
V <sub>PR</sub>	reverse polarity		–	6.0	V
	energy handling capability at outputs	V <sub>P</sub> = 0	–	200	mJ
IOSM	non-repetitive peak output current		–	6	A
IORM	repetitive peak output current		–	4	A
P <sub>tot</sub>	total power dissipation		–	60	W
T <sub>stg</sub>	storage temperature range		–55	+150	°C
T <sub>j</sub>	junction temperature		–	+150	°C

## THERMAL RESISTANCE

SYMBOL	PARAMETER	THERMAL RESISTANCE
R <sub>th vj-a</sub>	from virtual junction to ambient in free air	40 K/W
R <sub>th vj-c</sub>	from virtual junction to case (see Fig.3)	1.5 K/W

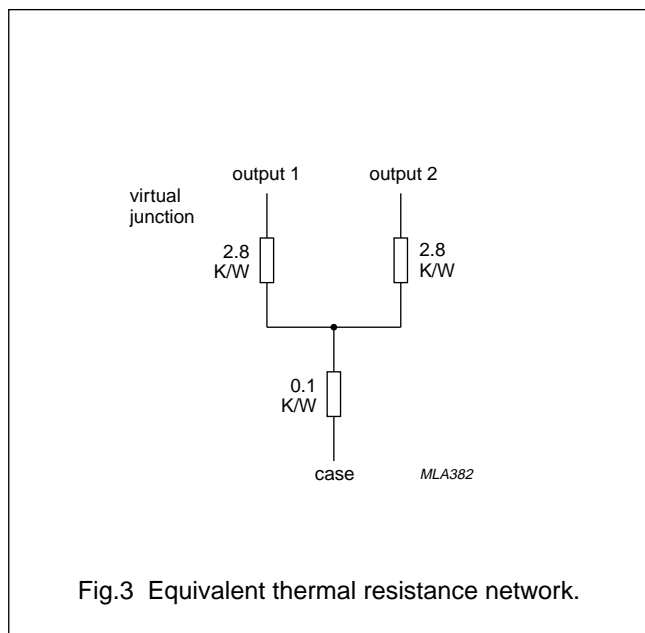

Fig.3 Equivalent thermal resistance network.

## 2 x 22 W BTL stereo car radio power amplifier with speaker protection

TDA1557Q

### DC CHARACTERISTICS

$V_P = 14.4\text{ V}$ ,  $T_{\text{amb}} = 25\text{ °C}$ , unless otherwise specified. See note 1.

SYMBOL	PARAMETER	CONDITIONS	MIN.	TYP.	MAX.	UNIT
<b>Supply</b>						
$V_P$	positive supply voltage range	note 2	6.0	14.4	18	V
$I_P$	quiescent current		–	80	160	mA
$V_O$	DC output voltage	note 3	–	6.9	–	V
$ \Delta V_{\text{os}} $	DC output offset voltage		–	–	250	mV
<b>Mute/stand-by switch</b>						
$V_{\text{sw}}$	switch-on voltage level		8.5	–	–	V
<b>MUTE CONDITION</b>						
$V_{\text{mute}}$	mute voltage		3.3	–	6.4	V
$V_O$	output signal in mute position	$V_I = 1\text{ V max}$ ; $f = 1\text{ kHz}$	–	–	20	mV
$ \Delta V_{\text{os}} $	DC output offset voltage		–	–	250	mV
<b>STAND-BY CONDITION</b>						
$V_{\text{sb}}$	stand-by voltage		0	–	2.0	V
$I_{\text{sb}}$	DC current in stand-by condition	$V_{11} \leq 0.5\text{ V}$ $0.5 < V_{11} \leq 2\text{ V}$	–	–	100	$\mu\text{A}$
			–	–	500	$\mu\text{A}$
$I_{\text{sw}}$	switch-on current		–	30	60	$\mu\text{A}$
$I_P$	positive supply current	short-circuit to GND; note 4	–	5.5	–	mA
<b>Loudspeaker protection</b>						
$ \Delta V_{4-6, 7-9} $	DC voltage across $R_L$		–	–	1.0	V

## 2 x 22 W BTL stereo car radio power amplifier with speaker protection

TDA1557Q

### AC CHARACTERISTICS

$V_P = 14.4\text{ V}$ ;  $R_L = 4\ \Omega$ ;  $f = 1\text{ kHz}$ ;  $T_{\text{amb}} = 25\text{ }^\circ\text{C}$ ; unless otherwise specified. See note 1.

SYMBOL	PARAMETER	CONDITIONS	MIN.	TYP.	MAX.	UNIT
$P_O$	output power	THD = 0.5%	15	17	–	W
		THD = 10%	20	22	–	W
		$V_P = 13.2\text{ V}$ ; THD = 0.5%	–	12	–	W
		$V_P = 13.2\text{ V}$ ; THD = 10%	–	17	–	W
THD	total harmonic distortion	$P_O = 1\text{ W}$	–	0.1	–	%
B	power bandwidth	THD = 0.5%; $P_O = -1\text{ dB}$ with respect to 15 W	–	20 to 15 000	–	Hz
$f_{\text{low}}$	low frequency roll-off	-1 dB; note 5	–	25	–	Hz
$f_{\text{high}}$	high frequency roll-off	-1 dB	20	–	–	kHz
$G_V$	closed loop voltage gain		45	46	47	dB
SVRR	supply voltage ripple rejection	ON; note 6	34	–	–	dB
		ON; note 7	38	–	–	dB
		ON; note 8	45	–	–	dB
		MUTE; notes 6 and 7	45	–	–	dB
		stand-by; notes 6 and 7	80	–	–	dB
$ Z_I $	input impedance		25	30	36	k $\Omega$
$V_{\text{no}}$	noise output voltage	ON; $R_S = 0$ ; note 9	–	325	500	$\mu\text{V}$
		$R_S = 10\text{ k}\Omega$ ; note 9	–	350	–	$\mu\text{V}$
		MUTE; notes 9 & 10	–	180	–	$\mu\text{V}$
$\alpha$	channel separation		40	–	–	dB
$ \Delta G_V $	channel unbalance		–	–	1	dB

### Notes to the characteristics

- All characteristics are measured using the circuit shown in Fig.4
- The circuit is DC adjusted at  $V_P = 6$  to 18 V and AC operating at  $V_P = 8.5$  to 18 V
- At  $18\text{ V} < V_P < 30\text{ V}$ , the DC output voltage  $\leq V_P/2$
- Conditions:  $V_{11} = 0$ ; short-circuit output to GND; switch  $V_{11}$  to MUTE or ON condition (rise time  $V_{11} > 10\ \mu\text{s}$ ).
- Frequency response externally fixed.
- Ripple rejection measured at the output with a source-impedance of  $0\ \Omega$  (max. ripple amplitude of 2 V) and a frequency of 100 Hz.
- Ripple rejection measured at the output with a source-impedance of  $0\ \Omega$  (max. ripple amplitude of 2 V) and a frequency between 1 and 10 kHz.
- Ripple rejection measured at the output with a source-impedance of  $0\ \Omega$  (max. ripple amplitude of 2 V) and a frequency between 100 Hz and 10 kHz. Pin 12 is decoupled with two diodes to ground.
- Noise voltage measured in a bandwidth of 20 Hz to 20 kHz.
- Noise output voltage independent of  $R_S$  ( $V_{\text{in}} = 0$ ).



2 x 22 W BTL stereo car radio power amplifier with speaker protection

TDA1557Q

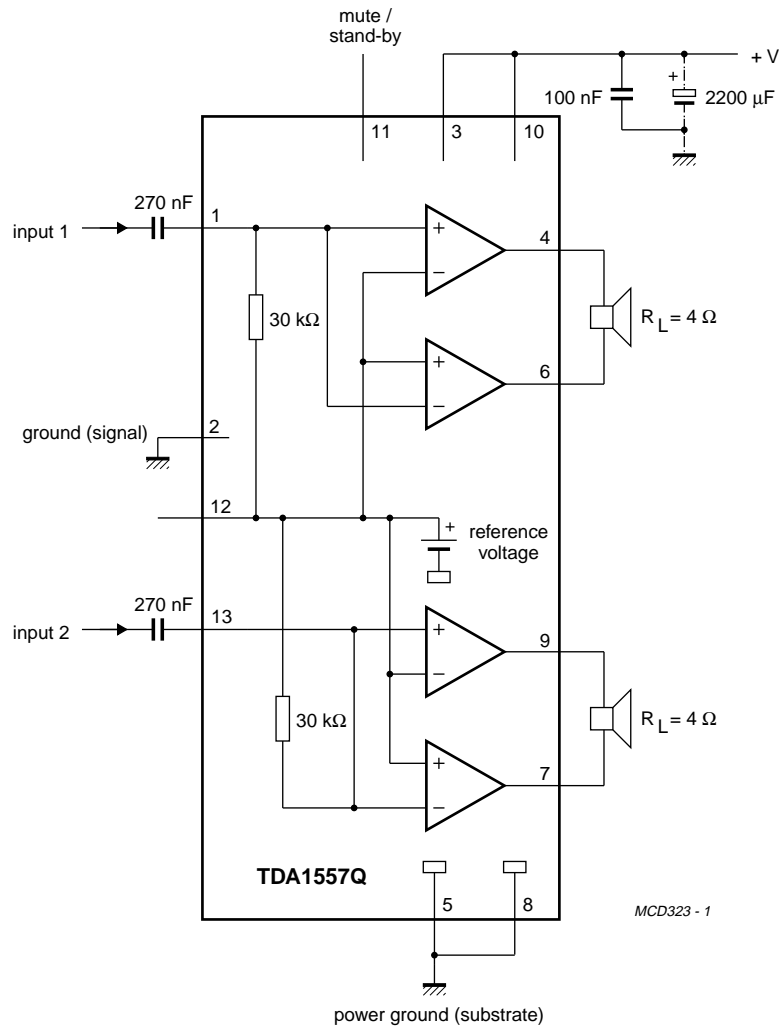

Fig.4 Stereo BTL application.

2 x 22 W BTL stereo car radio power amplifier with speaker protection

TDA1557Q

PACKAGE OUTLINE

DBS13P: plastic DIL-bent-SIL power package; 13 leads (lead length 12 mm)

SOT141-6

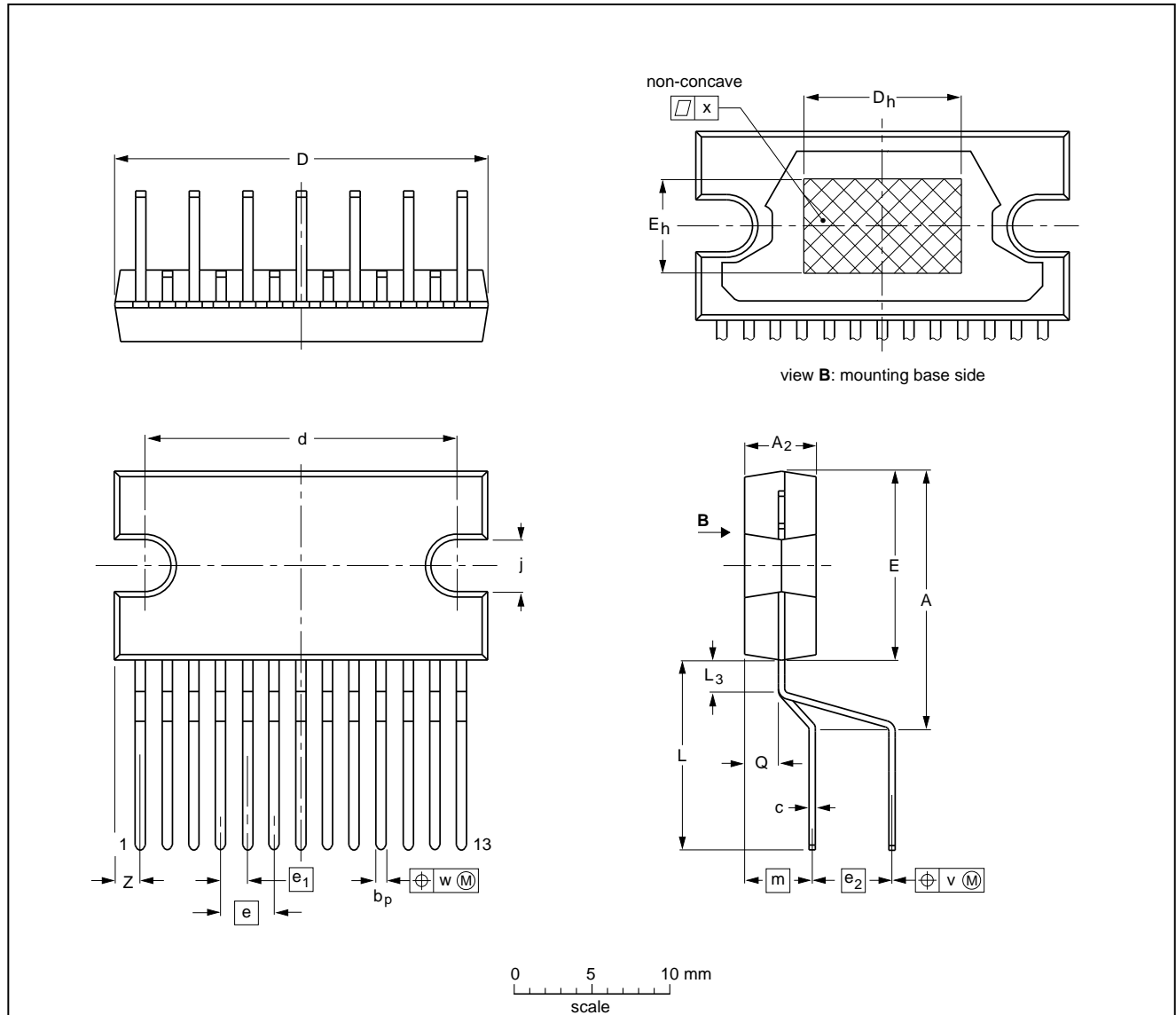

DIMENSIONS (mm are the original dimensions)

UNIT	A	A <sub>2</sub>	b <sub>p</sub>	c	D <sup>(1)</sup>	d	D <sub>h</sub>	E <sup>(1)</sup>	e	e <sub>1</sub>	e <sub>2</sub>	E <sub>h</sub>	j	L	L <sub>3</sub>	m	Q	v	w	x	Z <sup>(1)</sup>
mm	17.0 15.5	4.6 4.2	0.75 0.60	0.48 0.38	24.0 23.6	20.0 19.6	10	12.2 11.8	3.4	1.7	5.08	6	3.4 3.1	12.4 11.0	2.4 1.6	4.3	2.1 1.8	0.8	0.25	0.03	2.00 1.45

Note

1. Plastic or metal protrusions of 0.25 mm maximum per side are not included.

OUTLINE VERSION	REFERENCES				EUROPEAN PROJECTION	ISSUE DATE
	IEC	JEDEC	EIAJ			
SOT141-6						92-11-17 95-03-11

## 2 x 22 W BTL stereo car radio power amplifier with speaker protection

TDA1557Q

### SOLDERING

#### Introduction

There is no soldering method that is ideal for all IC packages. Wave soldering is often preferred when through-hole and surface mounted components are mixed on one printed-circuit board. However, wave soldering is not always suitable for surface mounted ICs, or for printed-circuits with high population densities. In these situations reflow soldering is often used.

This text gives a very brief insight to a complex technology. A more in-depth account of soldering ICs can be found in our "IC Package Databook" (order code 9398 652 90011).

#### Soldering by dipping or by wave

The maximum permissible temperature of the solder is 260 °C; solder at this temperature must not be in contact with the joint for more than 5 seconds. The total contact time of successive solder waves must not exceed 5 seconds.

The device may be mounted up to the seating plane, but the temperature of the plastic body must not exceed the specified maximum storage temperature ( $T_{stg\ max}$ ). If the printed-circuit board has been pre-heated, forced cooling may be necessary immediately after soldering to keep the temperature within the permissible limit.

#### Repairing soldered joints

Apply a low voltage soldering iron (less than 24 V) to the lead(s) of the package, below the seating plane or not more than 2 mm above it. If the temperature of the soldering iron bit is less than 300 °C it may remain in contact for up to 10 seconds. If the bit temperature is between 300 and 400 °C, contact may be up to 5 seconds.

### DEFINITIONS

Data sheet status	
Objective specification	This data sheet contains target or goal specifications for product development.
Preliminary specification	This data sheet contains preliminary data; supplementary data may be published later.
Product specification	This data sheet contains final product specifications.
Limiting values	
Limiting values given are in accordance with the Absolute Maximum Rating System (IEC 134). Stress above one or more of the limiting values may cause permanent damage to the device. These are stress ratings only and operation of the device at these or at any other conditions above those given in the Characteristics sections of the specification is not implied. Exposure to limiting values for extended periods may affect device reliability.	
Application information	
Where application information is given, it is advisory and does not form part of the specification.	

### LIFE SUPPORT APPLICATIONS

These products are not designed for use in life support appliances, devices, or systems where malfunction of these products can reasonably be expected to result in personal injury. Philips customers using or selling these products for use in such applications do so at their own risk and agree to fully indemnify Philips for any damages resulting from such improper use or sale.