

阅读申明

- 1.本站收集的数据手册和产品资料都来自互联网，版权归原作者所有。如读者和版权方有任何异议请及时告之，我们将妥善解决。
- 2.本站提供的中文数据手册是英文数据手册的中文翻译，其目的是协助用户阅读，该译文无法自动跟随原稿更新，同时也可能存在翻译上的不当。建议读者以英文原稿为参考以便获得更精准的信息。
- 3.本站提供的产品资料，来自厂商的技术支持或者使用者的心得体会等，其内容可能存在描述上的差异，建议读者做出适当判断。
- 4.如需与我们联系，请发邮件到marketing@iczoom.com，主题请标有“数据手册”字样。

Read Statement

1. The datasheets and other product information on the site are all from network reference or other public materials, and the copyright belongs to the original author and original published source. If readers and copyright owners have any objections, please contact us and we will deal with it in a timely manner.
2. The Chinese datasheets provided on the website is a Chinese translation of the English datasheets. Its purpose is for reader's learning exchange only and do not involve commercial purposes. The translation cannot be automatically updated with the original manuscript, and there may also be improper translations. Readers are advised to use the English manuscript as a reference for more accurate information.
3. All product information provided on the website refer to solutions from manufacturers' technical support or users the contents may have differences in description, and readers are advised to take the original article as the standard.
4. If you have any questions, please contact us at marketing@iczoom.com and mark the subject with "Datasheets" .



SANYO Semiconductors

DATA SHEET

An ON Semiconductor Company

LA42102 — Monolithic Linear IC Audio Output for TV application 10W × 2ch Power Amplifier

Overview

LA42102 is 10W 2-channel AF power amplifier intended for televisions.

Functions

- 10W × 2 channels ($V_{CC} = 14V$, $R_L = 8\Omega$).
- Standby function.
- Built-in mute function.
- Built-in various protection circuit (short to V_{CC} /short to ground/load shorting/overheating).

Specifications

Maximum Ratings at $T_a = 25^\circ C$

Parameter	Symbol	Conditions	Ratings	Unit
Maximum supply voltage	$V_{CC\ max}$		17	V
Allowable power dissipation	$P_d\ max$	Infinitely large heat sink	15	W
Maximum junction temperature	$T_j\ max$		150	$^\circ C$
Thermal resistance	θ_{jc}		3	$^\circ C/W$
Operating temperature	T_{opr}		-25 to +75	$^\circ C$
Storage temperature	T_{stg}		-40 to +150	$^\circ C$

Operating Conditions at $T_a = 25^\circ C$

Parameter	Symbol	Conditions	Ratings	Unit
Recommended supply voltage	V_{CC}		14	V
Recommended load resistance	R_L		8	Ω
Allowable operating supply voltage range	$V_{CC\ op}$	Under conditions such that Maximum ratings are not exceeded	10 to 17	V

■ Any and all SANYO Semiconductor Co.,Ltd. products described or contained herein are, with regard to "standard application", intended for the use as general electronics equipment (home appliances, AV equipment, communication device, office equipment, industrial equipment etc.). The products mentioned herein shall not be intended for use for any "special application" (medical equipment whose purpose is to sustain life, aerospace instrument, nuclear control device, burning appliances, transportation machine, traffic signal system, safety equipment etc.) that shall require extremely high level of reliability and can directly threaten human lives in case of failure or malfunction of the product or may cause harm to human bodies, nor shall they grant any guarantee thereof. If you should intend to use our products for applications outside the standard applications of our customer who is considering such use and/or outside the scope of our intended standard applications, please consult with us prior to the intended use. If there is no consultation or inquiry before the intended use, our customer shall be solely responsible for the use.

■ Specifications of any and all SANYO Semiconductor Co.,Ltd. products described or contained herein stipulate the performance, characteristics, and functions of the described products in the independent state, and are not guarantees of the performance, characteristics, and functions of the described products as mounted in the customer's products or equipment. To verify symptoms and states that cannot be evaluated in an independent device, the customer should always evaluate and test devices mounted in the customer's products or equipment.

SANYO Semiconductor Co., Ltd.

TOKYO OFFICE Tokyo Bldg., 1-10, 1 Chome, Ueno, Taito-ku, TOKYO, 110-8534 JAPAN

LA42102

Electrical Characteristics at $T_a = 25^\circ\text{C}$, $V_{CC} = 14\text{V}$, $R_L = 8\Omega$, $f = 1\text{kHz}$, $R_g = 600\Omega$

Parameter	Symbol	Conditions	Ratings			Unit
			min	typ	max	
Standby current	I_{st}	Amplifier OFF		0	10	μA
Quiescent current	I_{CCO}	$R_g = 0$, $R_L = \text{OPEN}$	40	70	140	mA
Output power	P_{O1}	THD = 10%	8	10		W
Total harmonic distortion	THD	$P_O = 1\text{W}$		0.06	0.2	%
Voltage gain	VG	$V_O = 0\text{dBm}$	33	35	37	dB
Output noise voltage	V_{NO}	$R_g = 0$, BPF = 20Hz to 20kHz		0.2	0.4	mVrms
Ripple rejection ratio	SVRR	$R_g = 0$, $f_R = 100\text{Hz}$, $V_{CCR} = 0\text{dBm}$	40	50		dB
Channel separation	CH.Sep	$R_g = 10\text{k}\Omega$, $V_O = 0\text{dBm}$	50	60		dB
Mute attenuation value	ATT	$V_O = 1\text{Vrms}$, BPF = 20Hz to 20kHz	80	90		dB
Mute control voltage (pin 6)	V_{mute}	Mute ON *1	1.7		3.0	V
		Mute OFF	0		0.5	V
Standby control voltage (pin 5)	V_{st}	Amplifier ON *1	2.5		V_{CC}	V
		Amplifier OFF	0		0.5	V
Input resistance	R_i		21	30	39	$\text{k}\Omega$

*1 : Note that the standby pin (pin 5) and MUTE pin (pin 6) incorporate the anti-electrostatic diode allowing the current to flow through the diode when the potential of V_{CC} 7 pin decreases below that of pin 5/6.

Package Dimensions

unit : mm (typ)

3107B

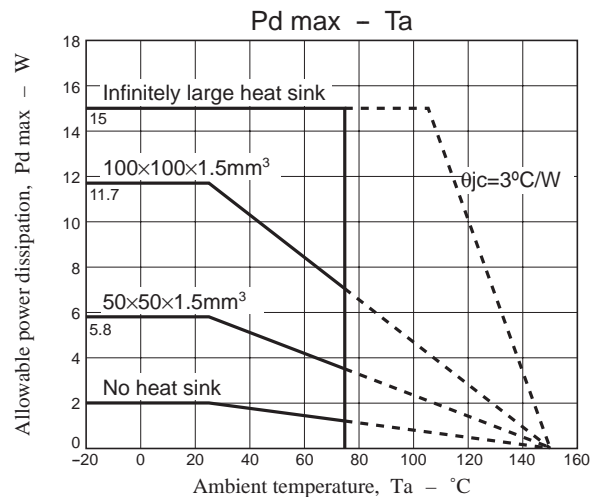
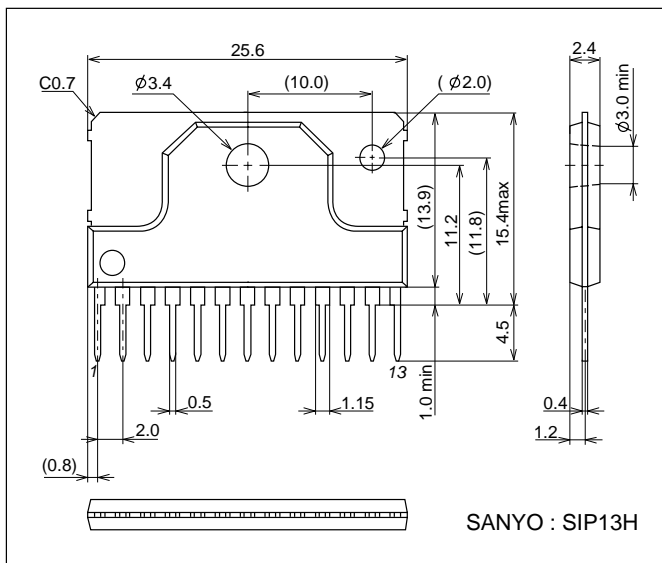

LA42102

Block Diagram

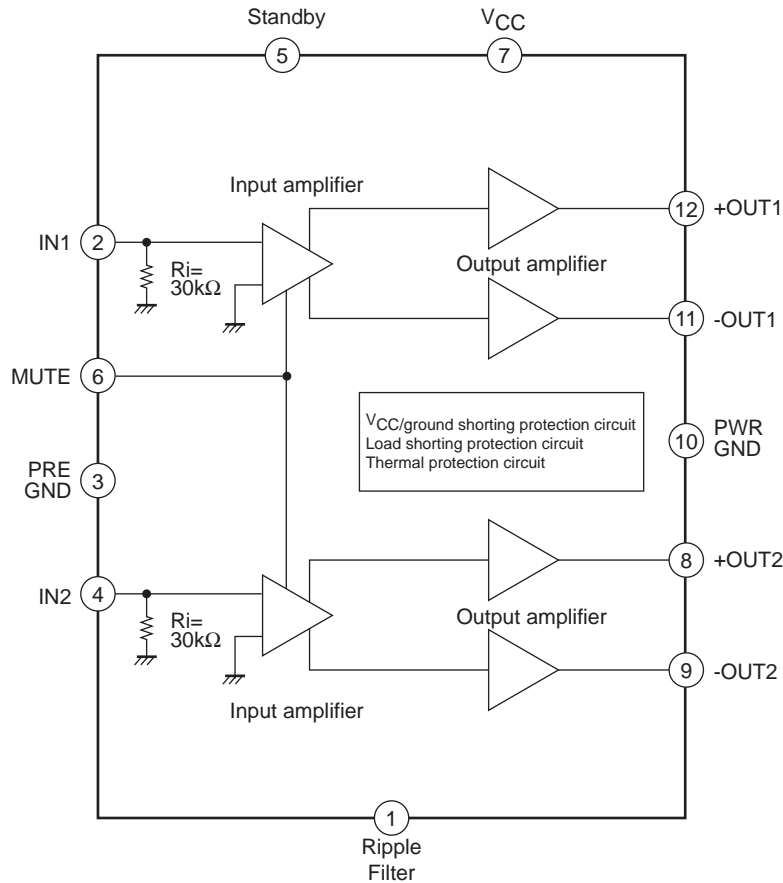

Test Circuit

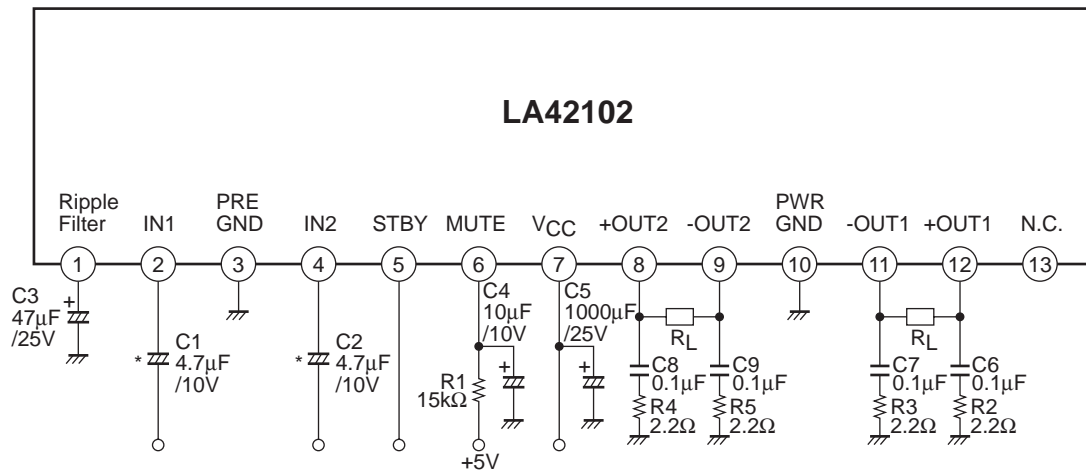

PCA00898

* LA42102 employs the zero-bias type input circuit, with the input pin potential being nearly zero (about 0.01V). Accordingly, the polarity must be determined according to the DC potential of a circuit connected to the previous stage of LA42102.

External Components

- C1, C2 : Input coupling capacitors, for which 4.7μF or less is recommended. LA42102 employs the zero-bias type input circuit, with the input pin potential being nearly zero. Accordingly, the polarity must be determined according to the DC potential of a circuit connected to the previous stage of LA42102.
- C3 : Capacitor for starting time of the ripple filter and amplifier, for which 47μF is recommended.
- C4, R1 : Capacitor and resistor for mute. C4 is necessary even when the mute function is not used.
- C5 : Power capacitor.
- C6 to C9 : Capacitor and resistor for oscillation prevention. For C6 to C9, the polyester film capacitor with superior temperature characteristics (Mylar capacitor) is recommended. Use R2 to R5 of 2.2Ω along with the capacitor.

1. Mute function (pin 6)

With the pin 6 voltage of 1.7V (minimum) or more, the mute function is turned ON.

Set the V_M application voltage so that the pin 6 voltage becomes 1.7V or more.

The mute time constant is determined by R1 and C4. Determine the constant after careful review because it is related to the pop sound at mute ON/OFF.

C4 is necessary even when the mute function is not used because it is related to the pop sound when the amplifier is turned ON.

Note that the MUTE pin (pin 6) incorporates the anti-electrostatic diode, allowing the current to flow through the diode when the potential of V_{CC} 7 pin decreases below that of pin 6.

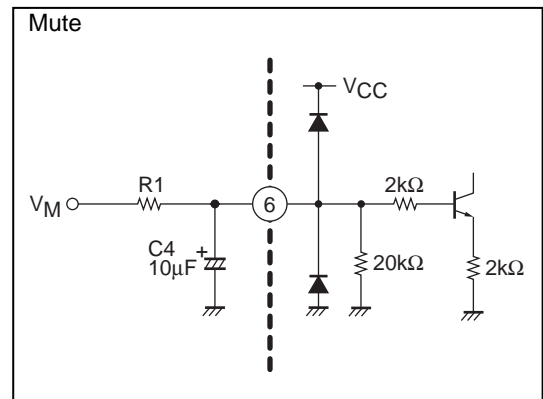

2. Standby function (pin 5)

The amplifier is turned ON when the voltage of 2.5V (minimum) or more is applied to pin 5.

Pin 5 control voltage

Pin 5 voltage	Amplifier	Standby
0 to 0.5	OFF	ON
2.5 to 15	ON	OFF

To suppress the inrush current to pin 5 when the V_{STB} application voltage is high, insert the control resistor (R_{STB}).

Example : To suppress the pin 5 inrush current to 500μA or less

$$R_{STB} = \frac{\text{Applied voltage } (V_{STB}) - 2V_{BE} \text{ (About 1.4V)}}{500\mu\text{A}} - 15\text{k}\Omega$$

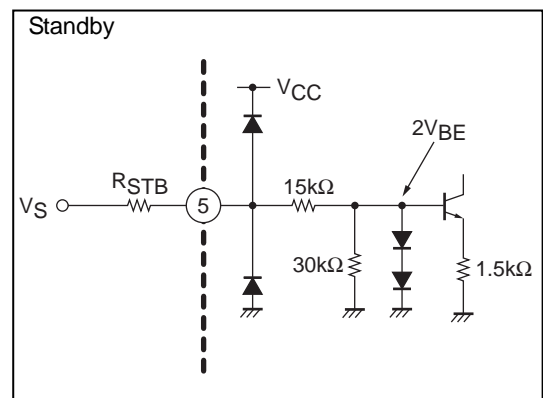

Note that the standby pin (pin 5) incorporates the anti-electrostatic diode, allowing the current to flow through the diode when the potential of V_{CC} pin 7 decreases below that of pin 5.

Cautions for us

1. Short-circuit (power-output short-circuit), ground fault (GND-output short-circuit), and load short-circuit protective circuits are incorporated. They are activated in case of abnormal connection.
These circuits remain active while such abnormal connection continues and is reset automatically when the abnormality is removed.
In certain conditions, the protective circuits may be locked and continue to be active even when the abnormality is removed. In this case, either enter the standby mode or turn OFF the power supply.
2. The thermal protection circuit is incorporated and is activated when the junction temperature (T_j) rises to about 160°C or more. The output is controlled to return gradually to the attenuated state.
3. When the product is used near the maximum rating, even the slightest change in the condition may cause exceeding of the maximum rating, resulting possibly in breakdown. Take the sufficient margin for the supply voltage, etc. and always use the product within a range never exceeding the maximum rating.

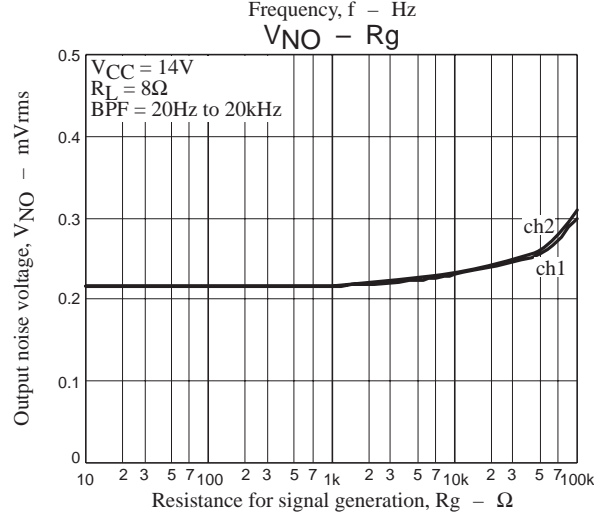
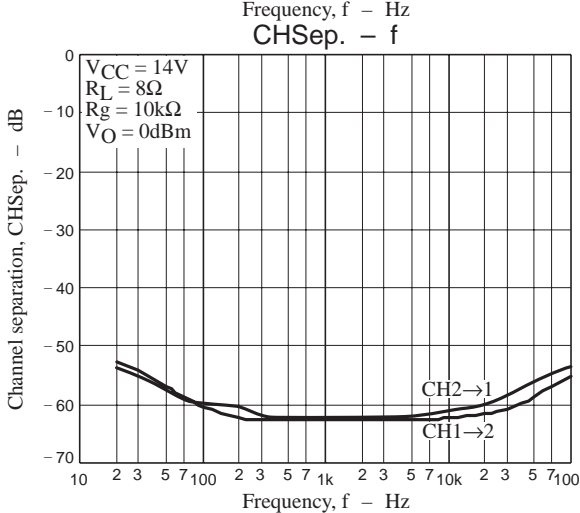
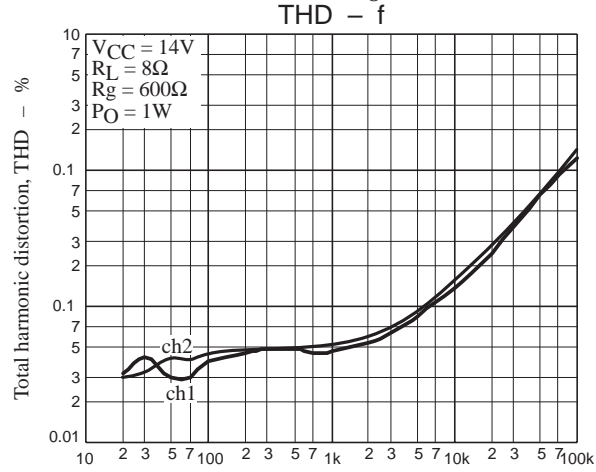
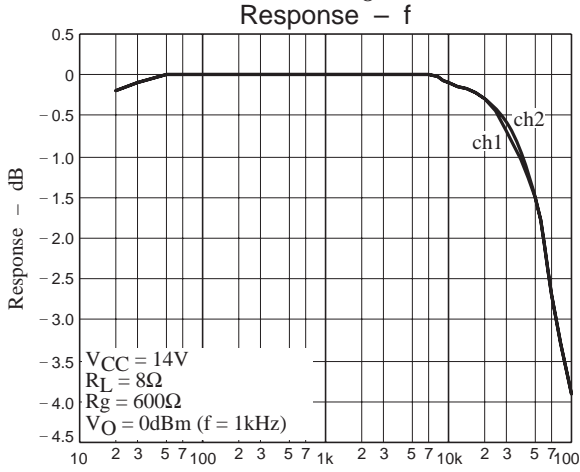
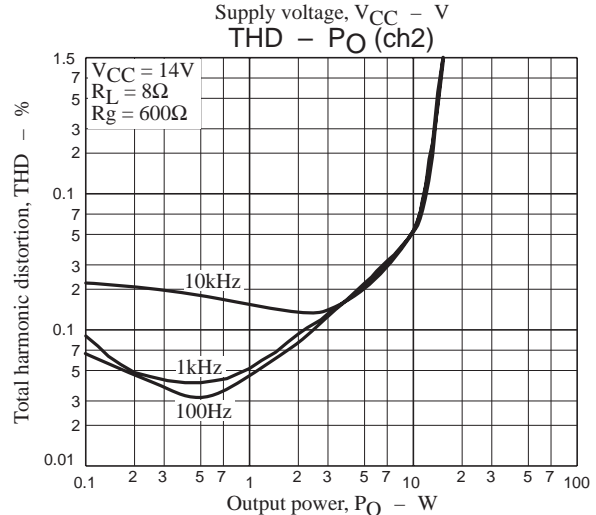
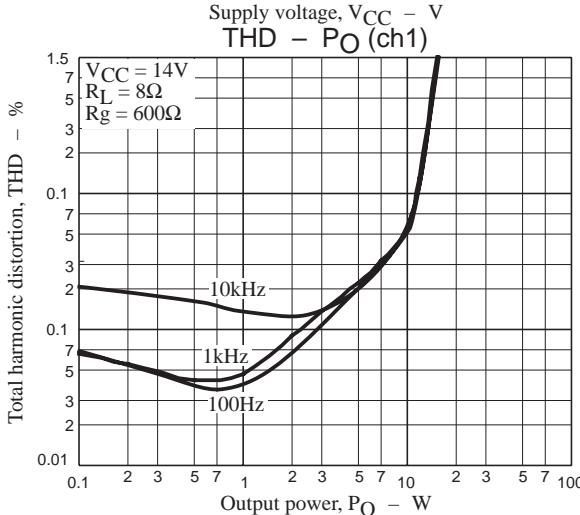
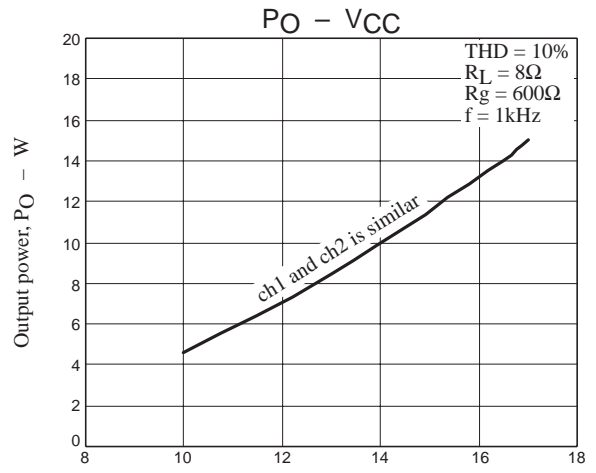
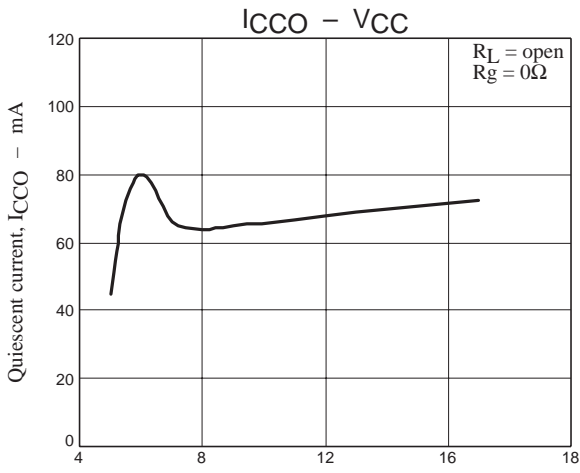

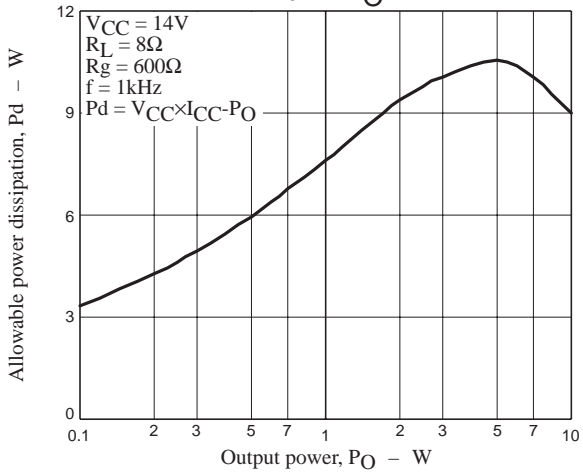
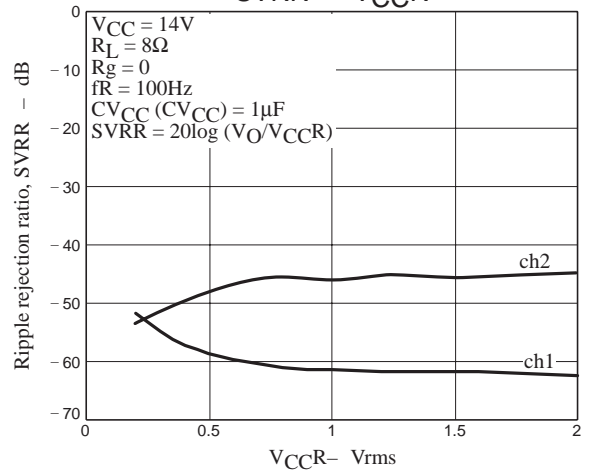
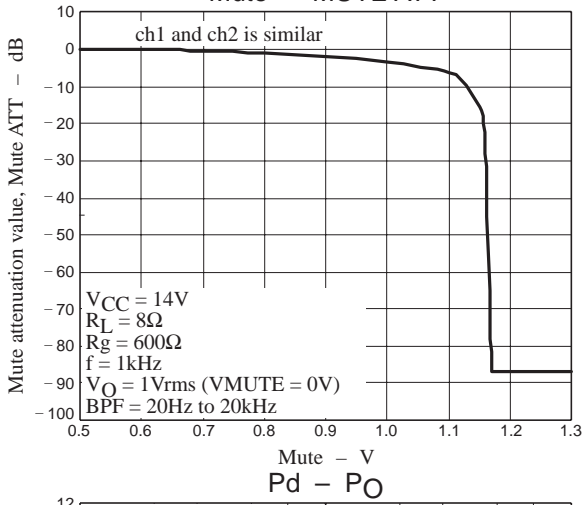
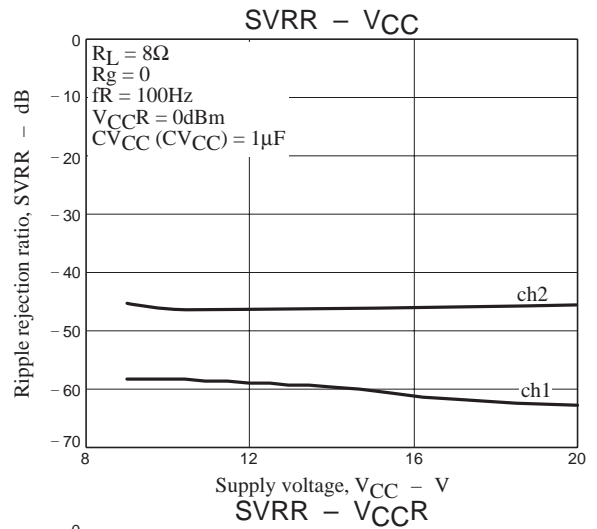
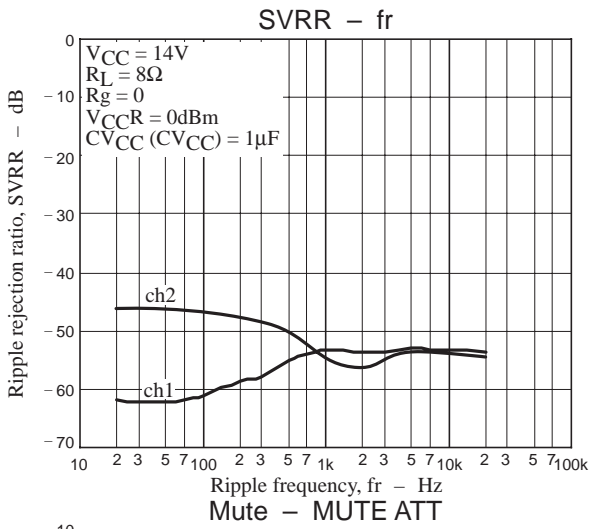

- SANYO Semiconductor Co.,Ltd. assumes no responsibility for equipment failures that result from using products at values that exceed, even momentarily, rated values (such as maximum ratings, operating condition ranges, or other parameters) listed in products specifications of any and all SANYO Semiconductor Co.,Ltd. products described or contained herein.
- SANYO Semiconductor Co.,Ltd. strives to supply high-quality high-reliability products, however, any and all semiconductor products fail or malfunction with some probability. It is possible that these probabilistic failures or malfunction could give rise to accidents or events that could endanger human lives, trouble that could give rise to smoke or fire, or accidents that could cause damage to other property. When designing equipment, adopt safety measures so that these kinds of accidents or events cannot occur. Such measures include but are not limited to protective circuits and error prevention circuits for safe design, redundant design, and structural design.
- In the event that any or all SANYO Semiconductor Co.,Ltd. products described or contained herein are controlled under any of applicable local export control laws and regulations, such products may require the export license from the authorities concerned in accordance with the above law.
- No part of this publication may be reproduced or transmitted in any form or by any means, electronic or mechanical, including photocopying and recording, or any information storage or retrieval system, or otherwise, without the prior written consent of SANYO Semiconductor Co.,Ltd.
- Any and all information described or contained herein are subject to change without notice due to product/technology improvement, etc. When designing equipment, refer to the "Delivery Specification" for the SANYO Semiconductor Co.,Ltd. product that you intend to use.
- Information (including circuit diagrams and circuit parameters) herein is for example only; it is not guaranteed for volume production.
- Upon using the technical information or products described herein, neither warranty nor license shall be granted with regard to intellectual property rights or any other rights of SANYO Semiconductor Co.,Ltd. or any third party. SANYO Semiconductor Co.,Ltd. shall not be liable for any claim or suits with regard to a third party's intellectual property rights which has resulted from the use of the technical information and products mentioned above.

This catalog provides information as of May, 2007. Specifications and information herein are subject to change without notice.