

阅读申明

- 1.本站收集的数据手册和产品资料都来自互联网，版权归原作者所有。如读者和版权方有任何异议请及时告之，我们将妥善解决。
- 2.本站提供的中文数据手册是英文数据手册的中文翻译，其目的是协助用户阅读，该译文无法自动跟随原稿更新，同时也可能存在翻译上的不当。建议读者以英文原稿为参考以便获得更精准的信息。
- 3.本站提供的产品资料，来自厂商的技术支持或者使用者的心得体会等，其内容可能存在描述上的差异，建议读者做出适当判断。
- 4.如需与我们联系，请发邮件到marketing@iczoom.com，主题请标有“数据手册”字样。

Read Statement

1. The datasheets and other product information on the site are all from network reference or other public materials, and the copyright belongs to the original author and original published source. If readers and copyright owners have any objections, please contact us and we will deal with it in a timely manner.
2. The Chinese datasheets provided on the website is a Chinese translation of the English datasheets. Its purpose is for reader's learning exchange only and do not involve commercial purposes. The translation cannot be automatically updated with the original manuscript, and there may also be improper translations. Readers are advised to use the English manuscript as a reference for more accurate information.
3. All product information provided on the website refer to solutions from manufacturers' technical support or users the contents may have differences in description, and readers are advised to take the original article as the standard.
4. If you have any questions, please contact us at marketing@iczoom.com and mark the subject with "Datasheets" .



SANYO Semiconductors

DATA SHEET

LA74309TT — Monolithic Linear IC Microphone Amplifier for Digital Still Camera

Overview

LA74309TT is a microphone amplifier for digital still cameras that have mono audio recording. The analog signal processing for the recording of the digital still camera or other equipment can be easily composed, because the MIC power supply and the ALC circuit are built-in. Moreover, the regulator is built-in, therefore external regulator IC is unnecessary.

Features

- Microphone (MIC) amplifier (+20dB)
- MIC power supply with built-in pull-up resistor
- Automatic level control (ALC) amplifier (output level=-1dBV \approx 2.5Vpp)
- 3rd order LPF (fc=11kHz)
- 3.3V regulator (internal supply voltage: V_{CCA} \approx 3.0V)
- Standby control (I_{CC} \leq 10 μ A)

Specifications

Maximum Ratings at Ta=25°C

Parameter	Symbol	Conditions	Ratings	Unit
Maximum power supply voltage	V _{CC} max		4.0	V
Allowable power dissipation	P _d max	Ta \leq 85°C	50	mW
Operating temperature	T _{opr}		-20 to +85	°C
Storage temperature	T _{stg}		-55 to +150	°C

■ Any and all SANYO Semiconductor Co.,Ltd. products described or contained herein are, with regard to "standard application", intended for the use as general electronics equipment (home appliances, AV equipment, communication device, office equipment, industrial equipment etc.). The products mentioned herein shall not be intended for use for any "special application" (medical equipment whose purpose is to sustain life, aerospace instrument, nuclear control device, burning appliances, transportation machine, traffic signal system, safety equipment etc.) that shall require extremely high level of reliability and can directly threaten human lives in case of failure or malfunction of the product or may cause harm to human bodies, nor shall they grant any guarantee thereof. If you should intend to use our products for applications outside the standard applications of our customer who is considering such use and/or outside the scope of our intended standard applications, please consult with us prior to the intended use. If there is no consultation or inquiry before the intended use, our customer shall be solely responsible for the use.

■ Specifications of any and all SANYO Semiconductor Co.,Ltd. products described or contained herein stipulate the performance, characteristics, and functions of the described products in the independent state, and are not guarantees of the performance, characteristics, and functions of the described products as mounted in the customer's products or equipment. To verify symptoms and states that cannot be evaluated in an independent device, the customer should always evaluate and test devices mounted in the customer's products or equipment.

SANYO Semiconductor Co., Ltd.

TOKYO OFFICE Tokyo Bldg., 1-10, 1 Chome, Ueno, Taito-ku, TOKYO, 110-8534 JAPAN

LA74309TT

Operating Conditions at Ta = 25°C

Parameter	Symbol	Conditions	Ratings	Unit
Recommended power supply voltage	V _{CC}		3.3	V
Operating voltage range of V _{CC}	V _{CC} op		3.1 to 3.6	V

Electrical Characteristics at Ta=25°C, V_{CC}=3.3V, f=1kHz

Parameter	Symbol	Conditions	Ratings			Unit
			min	typ	max	
Current Dissipation						
V _{CC} no signal current dissipation	I _{CC}	V _{CC} =3.3V, Active mode (Pin3=3V)	3.9	5.3	6.7	mA
V _{CC} standby current dissipation	I _{CC} S	V _{CC} =3.3V, Standby mode (Pin3=0V)			10	μA
REC output system						
Standard REC output level	VOR	V _{IN} =-49dBV at ALC IN pin (=Standard level)	-10	-9	-8	dBV
Standard REC output distortion	HDR	ALC IN, V _{IN} =-49dBV, THD from 2nd to 5th harmonic		0.1	0.2	%
ALC characteristics	ALM	ALC IN, V _{IN} =-17dBV (=Standard level +32dB)	-3	-1		dBV
ALC THD	ALMD	ALC IN, V _{IN} =-17dBV (=Standard level +32dB), THD from 2nd to 5th harmonic		0.25	1	%
ALC IN maximum input level	VINRMX	REC output THD≤3%			-10	dBV
REC output noise level	VNOR	No signal at MIC IN pin, with JIS-A Filter		-53	-47	dBV
REC output frequency characteristics 1	FEQR1	ALC IN, V _{IN} =-17dBV, The output level ratio at f=11kHz/1kHz	-5	-3	-1	dB
REC output frequency characteristics 2	FEQR2	ALC IN, V _{IN} =-17dBV, The output level ratio at f=22kHz/1kHz		-18	-12	dB
REC output frequency characteristics 3	FEQR3	ALC IN, V _{IN} =-17dBV, The output level ratio at f=100kHz/1kHz		-55	-45	dB
MIC output system						
MIC voltage gain	VGMIC	V _{IN} =-39dBV at MIC IN pin	19	20	21	dB
MIC output THD	HDMIC	MIC IN, V _{IN} =-39dBV, THD from 2nd to 5th harmonic		0.03	0.1	%
MIC IN maximum input level	VINMMX	MIC output THD=3%			-30	dBV
MIC V _{CC} output DC voltage	VMIC	With 6.2kΩ load	1.5	1.7	1.9	V

Package Dimensions

unit : mm (typ)

3297

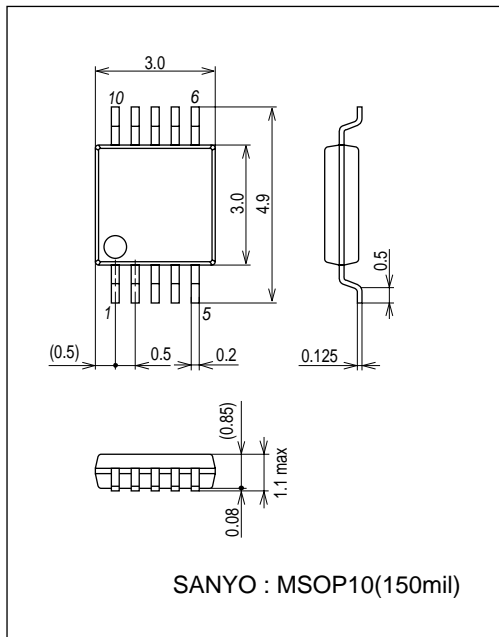

LA74309TT

Pin Description

Pin No.	Pin Description
1	GND
2	ALC input
3	STANDBY CTL
4	MIC output
5	MIC input
6	Ripple removal for VREF
7	Internal MIC power supply
8	ALC DET
9	REC output
10	V _{CC}

Equivalent Circuit Block Diagram & Application Circuit

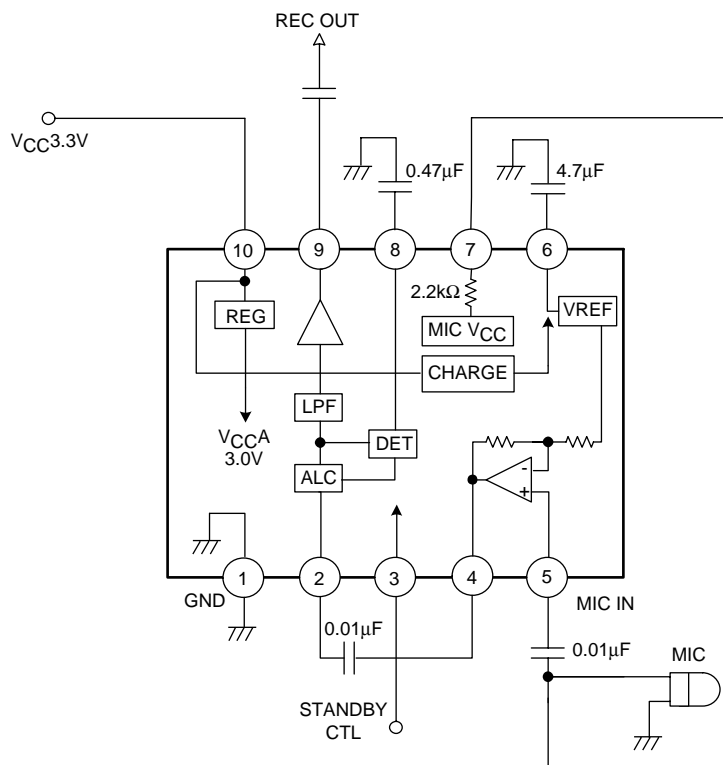

ILA07158

LA74309TT

Pin Functions

PIN No.	Pin Name	DC voltage	AC voltage	Functions	Equivalent Circuit
1	GND	0V		Ground	
2	ALC IN	1.60V	Output level=-49dBV (At MIC IN=-69dBV) Maximum input level =-10dBV	ALC input	
3	STANDBY CTL			Standby control Over 2V: Standby OFF	
4	MIC OUT	1.60V	Output level=-49dBV (At MIC IN=-69dBV)	MIC output	
5	MIC IN	1.60V	Standard input level =-69dBV Maximum input level =-30dBV	MIC input	
6	VREF	2.30V		MIC V _{CC} and ripple rejection pin for VREFL	
7	INT MIC V _{CC}	2.30V		MIC power supply	

Continued on next page.

LA74309TT

Continued from preceding page.

PIN No.	Pin Name	DC voltage	AC voltage	Functions	Equivalent Circuit
8	ALC DET			ALC detector	
9	REC OUT	1.60V	Output level=-9dBV (At MIC IN=-69dBV)	REC output	
10	V _{CC}	3.3V		Power supply	

- SANYO Semiconductor Co.,Ltd. assumes no responsibility for equipment failures that result from using products at values that exceed, even momentarily, rated values (such as maximum ratings, operating condition ranges, or other parameters) listed in products specifications of any and all SANYO Semiconductor Co.,Ltd. products described or contained herein.
- SANYO Semiconductor Co.,Ltd. strives to supply high-quality high-reliability products, however, any and all semiconductor products fail or malfunction with some probability. It is possible that these probabilistic failures or malfunction could give rise to accidents or events that could endanger human lives, trouble that could give rise to smoke or fire, or accidents that could cause damage to other property. When designing equipment, adopt safety measures so that these kinds of accidents or events cannot occur. Such measures include but are not limited to protective circuits and error prevention circuits for safe design, redundant design, and structural design.
- In the event that any or all SANYO Semiconductor Co.,Ltd. products described or contained herein are controlled under any of applicable local export control laws and regulations, such products may require the export license from the authorities concerned in accordance with the above law.
- No part of this publication may be reproduced or transmitted in any form or by any means, electronic or mechanical, including photocopying and recording, or any information storage or retrieval system, or otherwise, without the prior written consent of SANYO Semiconductor Co.,Ltd.
- Any and all information described or contained herein are subject to change without notice due to product/technology improvement, etc. When designing equipment, refer to the "Delivery Specification" for the SANYO Semiconductor Co.,Ltd. product that you intend to use.
- Information (including circuit diagrams and circuit parameters) herein is for example only; it is not guaranteed for volume production.
- Upon using the technical information or products described herein, neither warranty nor license shall be granted with regard to intellectual property rights or any other rights of SANYO Semiconductor Co.,Ltd. or any third party. SANYO Semiconductor Co.,Ltd. shall not be liable for any claim or suits with regard to a third party's intellectual property rights which has resulted from the use of the technical information and products mentioned above.

This catalog provides information as of August, 2007. Specifications and information herein are subject to change without notice.