

阅读申明

- 1.本站收集的数据手册和产品资料都来自互联网，版权归原作者所有。如读者和版权方有任何异议请及时告之，我们将妥善解决。
- 2.本站提供的中文数据手册是英文数据手册的中文翻译，其目的是协助用户阅读，该译文无法自动跟随原稿更新，同时也可能存在翻译上的不当。建议读者以英文原稿为参考以便获得更精准的信息。
- 3.本站提供的产品资料，来自厂商的技术支持或者使用者的心得体会等，其内容可能存在描述上的差异，建议读者做出适当判断。
- 4.如需与我们联系，请发邮件到marketing@iczoom.com，主题请标有“数据手册”字样。

Read Statement

1. The datasheets and other product information on the site are all from network reference or other public materials, and the copyright belongs to the original author and original published source. If readers and copyright owners have any objections, please contact us and we will deal with it in a timely manner.
2. The Chinese datasheets provided on the website is a Chinese translation of the English datasheets. Its purpose is for reader's learning exchange only and do not involve commercial purposes. The translation cannot be automatically updated with the original manuscript, and there may also be improper translations. Readers are advised to use the English manuscript as a reference for more accurate information.
3. All product information provided on the website refer to solutions from manufacturers' technical support or users the contents may have differences in description, and readers are advised to take the original article as the standard.
4. If you have any questions, please contact us at marketing@iczoom.com and mark the subject with "Datasheets" .

KA1458

Dual Operational Amplifier

Features

- Internal frequency compensation
- Short circuit protection
- Large common mode and differential voltage range
- No latch up
- Low power consumption

Description

The KA1458 series are dual general purpose operational amplifiers, having short circuits protected and require no external components for frequency compensation. High common mode voltage range and absence of "latch up" make the KA1458 ideal for use as voltage followers. The high gain and wide range of operating voltage provides superior performance in integrator, summing amplifier and general feedback applications.

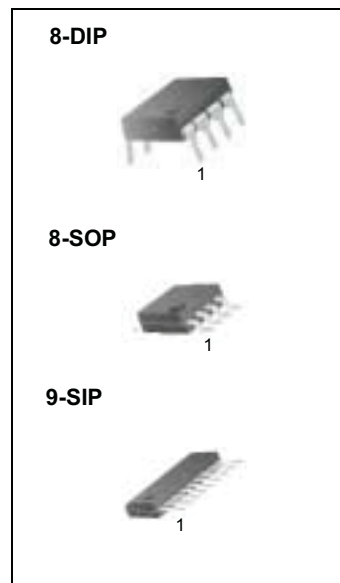

Internal Block Diagram

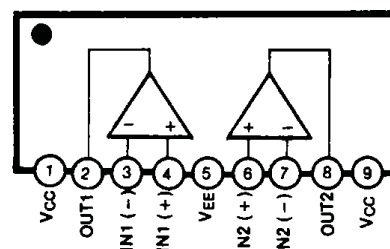
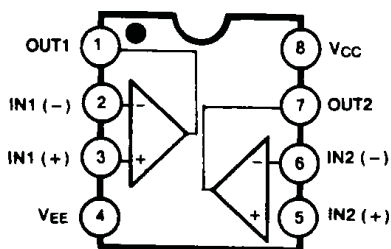

Schematic Diagram

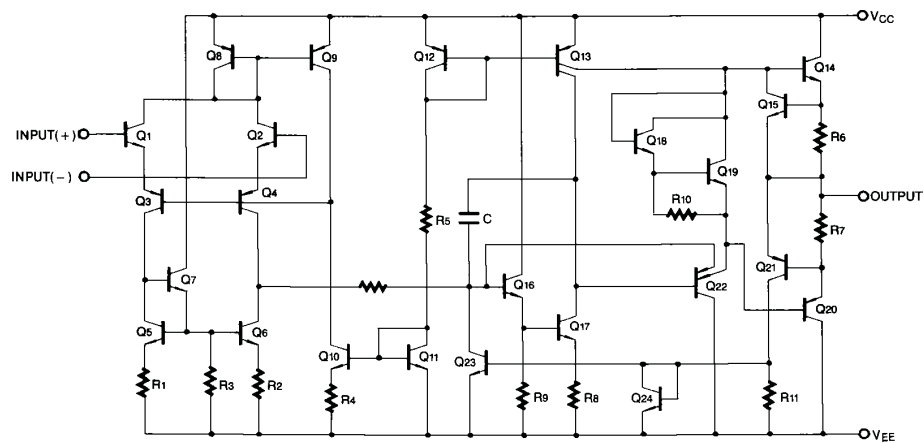

Absolute Maximum Ratings

Parameter	Symbol	Value	Unit
Power Supply Voltage	VCC	±18	V
Input Differential Voltage	V _{I(DIFF)}	30	V
Input Voltage	V _I	±15	V
Operating Temperature Range KA1458	T _{OPR}	0 ~ + 70	°C
Storage Temperature Range	T _{STG}	- 65 ~ + 150	°C

Electrical Characteristics

(VCC = + 15V, VEE = - 15V, TA = 25 °C unless otherwise specified)

Parameter	Symbol	Conditions	KA1458			Unit							
			Min.	Typ.	Max.								
Input Offset Voltage	V _{IO}	R _S ≤ 10KΩ	-	2.0	10	mV							
Input Offset Current	I _{IO}	-	-	20	300	nA							
Input Bias Current	I _{BIAS}	-	-	80	700	nA							
Large Signal Voltage Gain	G _V	V _{O(P-P)} = ± 10V, R _L ≥ 2.0KΩ	20	200	-	V/mV							
Input Voltage Range	V _{I(R)}	-	± 11	± 13	-	V							
Input Resistance	R _I	-	0.3	1.0	-	MΩ							
Common Mode Rejection Ratio	CMRR	-	60	90	-	dB							
Power Supply Rejection Ratio	PSRR	-	77	90	-	dB							
Supply Current (Both Amplifier)	I _{CC}	-	-	2.3	8.0	mA							
Output Voltage Swing	V _{O(PP)}	R _S ≤ 10KΩ	± 11	± 14	-	V							
		R _S ≤ 2KΩ	± 9	± 13	-								
Output Short Circuit Current	I _{SC}	-	-	20	-	mA							
Power Consumption	P _C	V _O = 0V	-	70	240	mW							
Transient Response (Unity Gain)													
							Rise Time	T _R	V _I = 20mV, R _L ≥ 2KΩ, C _L ≤ 100pF	-	0.3	-	μs
							Overshoot	OS	V _I = 20mV, R _L ≥ 2KΩ, C _L ≤ 100pF	-	15	-	%
							Slew Rate	SR	V _I = 10V, R _L ≥ 2KΩ, C _L ≤ 100pF	-	0.5	-	V/μs

Electrical Characteristics

(VCC = +15V, VEE = -15V, Note1 unless otherwise specified)

Parameter	Symbol	Conditions	KA1458			Unit
			Min.	Typ.	Max.	
Input Offset Voltage	V _{IO}	R _S ≤ 10KΩ	-	-	12	mV
Input Offset Current	I _{IO}	-	-	-	400	nA
Input Bias Current	I _{BIAS}	-	-	-	1000	nA
Large Signal Voltage Gain	G _V	V _{O(P-P)} = ± 10V, R _L ≤ 2.0KΩ	15	-	-	V/mV
Common Mode Rejection Ratio	CMRR	R _S ≥ 10KΩ	70	90	-	dB
Power Supply Rejection Ratio	PSRR	R _S ≥ 10KΩ	77	90	-	dB
Output Voltage Swing	V _{O(P.P)}	R _L = 10KΩ	± 11	± 14	-	V
		R _L = 2KΩ	± 9	± 13	-	
Input Voltage Range	V _{I(R)}	-	± 12	-	-	V

Note:

1. KA1458 : 0°C ≤ T_A ≤ 70°C

Typical Performance Characteristics

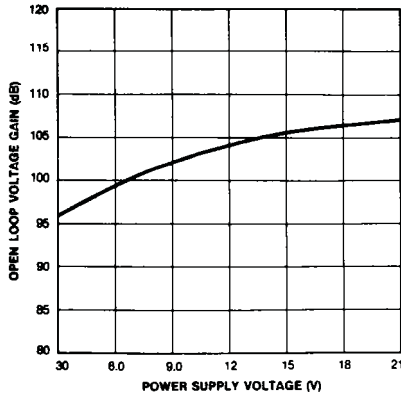

Figure 1. Open-Loop Voltage Gain vs Power Supply Voltages

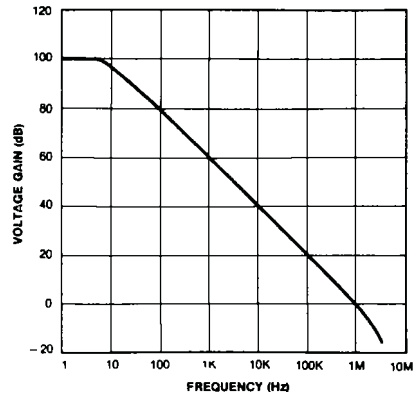

Figure 2. Open-Loop Frequency Response

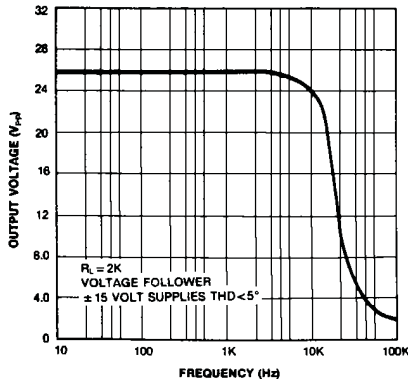

Figure 3. Power Bandwidth (Large Signal Output Swing vs Frequency)

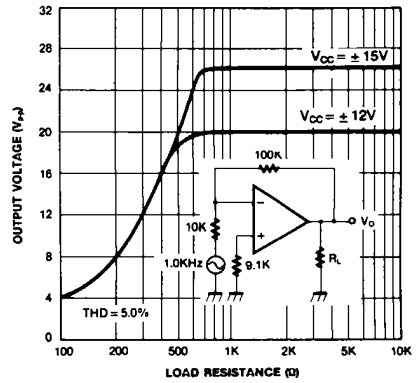
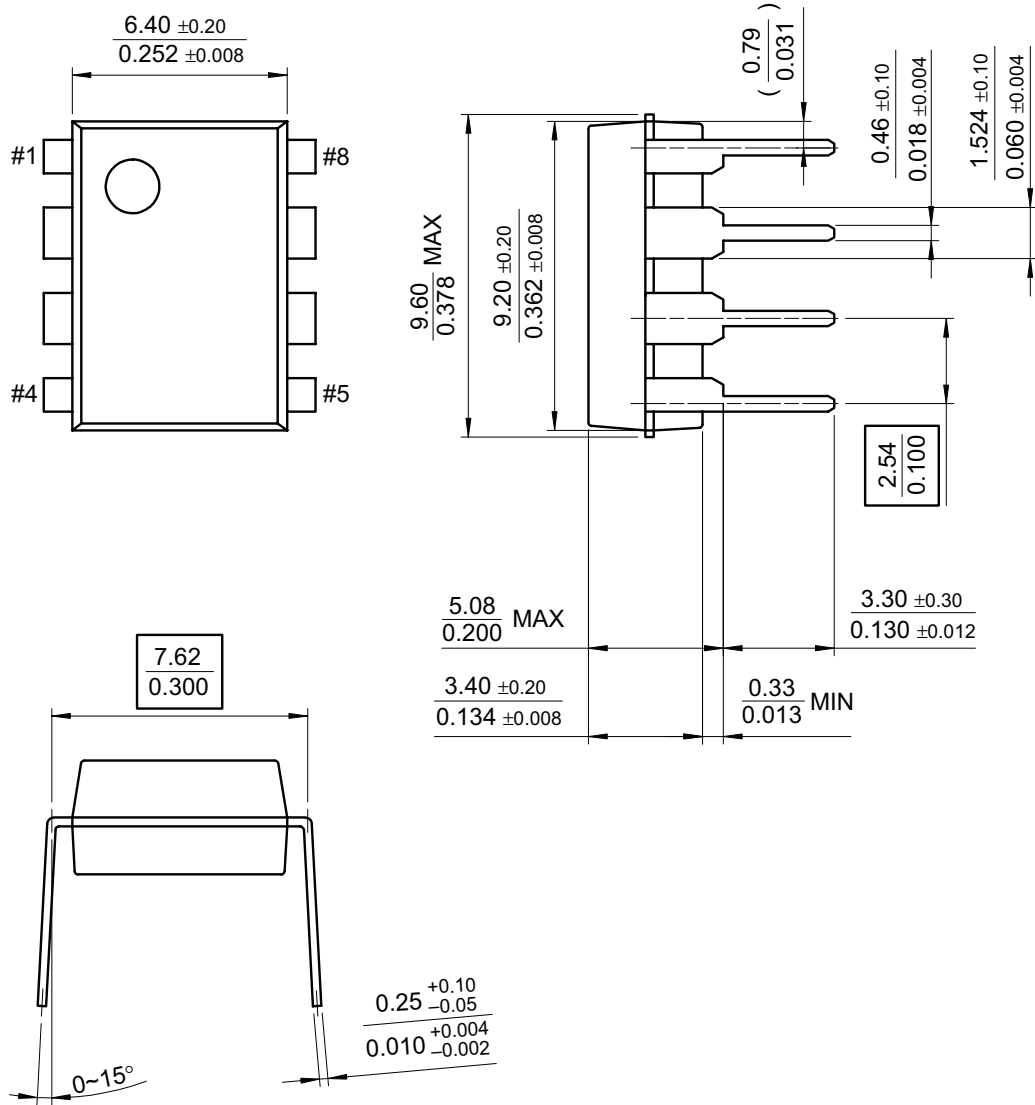

Figure 4. Output Voltage Swing vs Load Resistance

Mechanical Dimensions

Package

8-DIP



Mechanical Dimensions (Continued)

Package

8-SOP

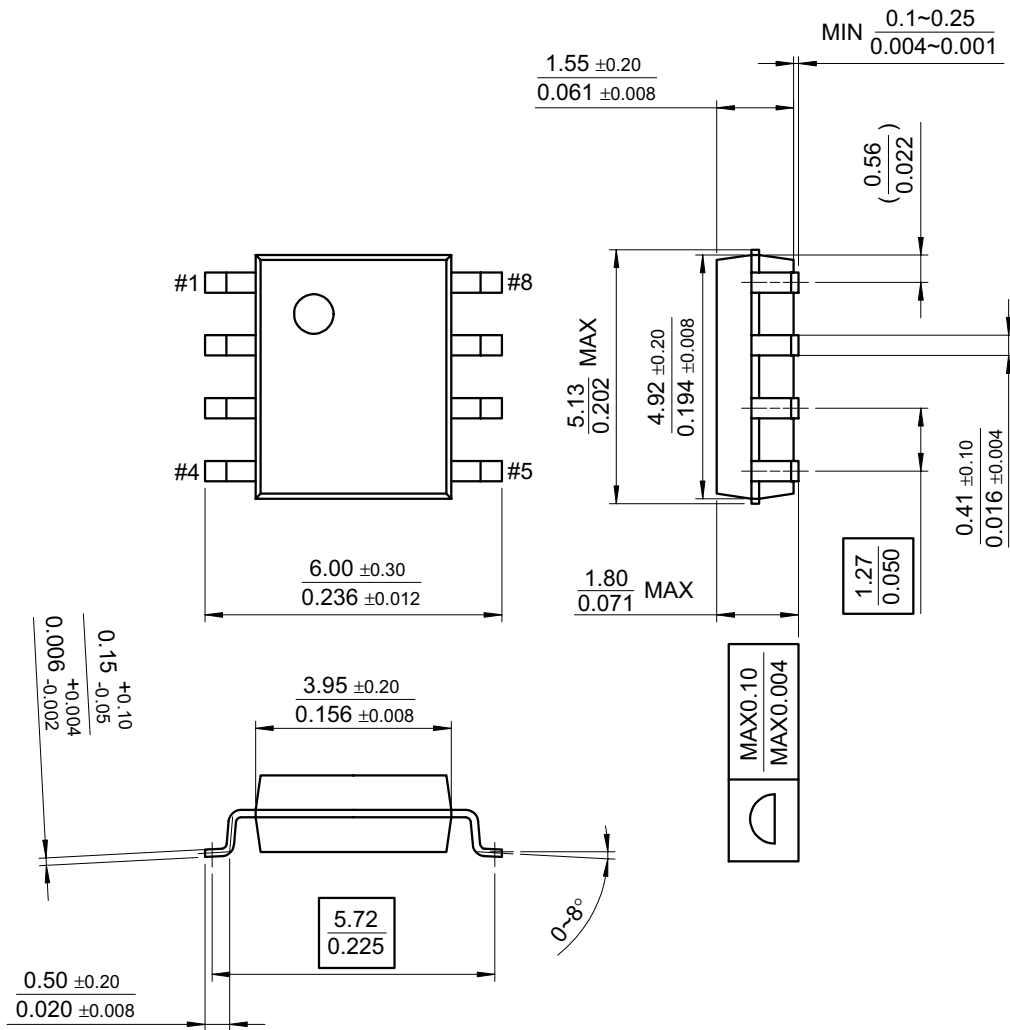

Mechanical Dimensions (Continued)

Package

9-SIP

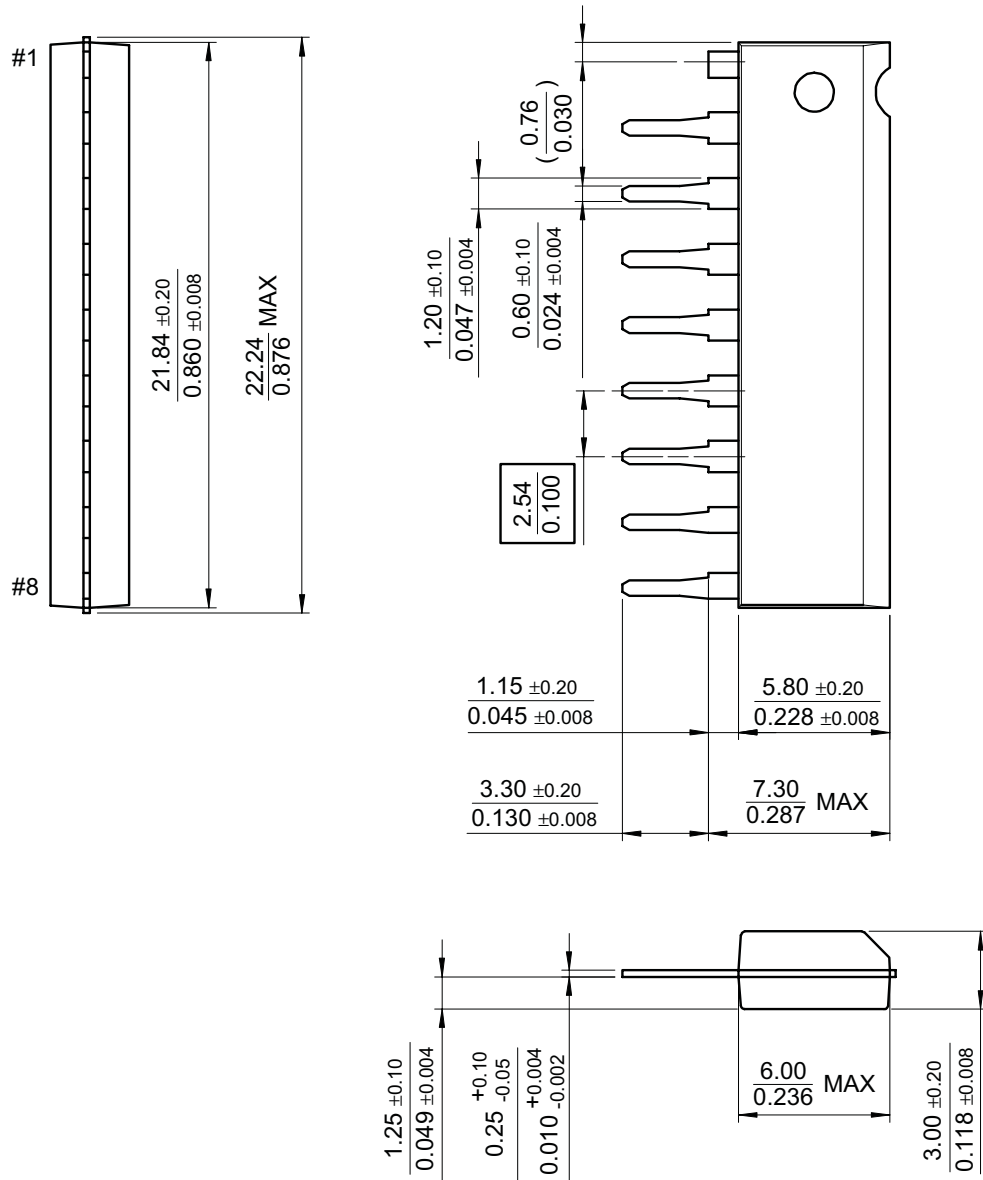

Ordering Information

Product Number	Package	Operating Temperature
KA1458	8-DIP	0 ~ + 70°C
KA1458D	8-SOP	
KA1458S	9-SIP	

DISCLAIMER

FAIRCHILD SEMICONDUCTOR RESERVES THE RIGHT TO MAKE CHANGES WITHOUT FURTHER NOTICE TO ANY PRODUCTS HEREIN TO IMPROVE RELIABILITY, FUNCTION OR DESIGN. FAIRCHILD DOES NOT ASSUME ANY LIABILITY ARISING OUT OF THE APPLICATION OR USE OF ANY PRODUCT OR CIRCUIT DESCRIBED HEREIN; NEITHER DOES IT CONVEY ANY LICENSE UNDER ITS PATENT RIGHTS, NOR THE RIGHTS OF OTHERS.

LIFE SUPPORT POLICY

FAIRCHILD'S PRODUCTS ARE NOT AUTHORIZED FOR USE AS CRITICAL COMPONENTS IN LIFE SUPPORT DEVICES OR SYSTEMS WITHOUT THE EXPRESS WRITTEN APPROVAL OF THE PRESIDENT OF FAIRCHILD SEMICONDUCTOR CORPORATION. As used herein:

1. Life support devices or systems are devices or systems which, (a) are intended for surgical implant into the body, or (b) support or sustain life, and (c) whose failure to perform when properly used in accordance with instructions for use provided in the labeling, can be reasonably expected to result in a significant injury of the user.
2. A critical component in any component of a life support device or system whose failure to perform can be reasonably expected to cause the failure of the life support device or system, or to affect its safety or effectiveness.