

阅读申明

- 1.本站收集的数据手册和产品资料都来自互联网，版权归原作者所有。如读者和版权方有任何异议请及时告之，我们将妥善解决。
- 2.本站提供的中文数据手册是英文数据手册的中文翻译，其目的是协助用户阅读，该译文无法自动跟随原稿更新，同时也可能存在翻译上的不当。建议读者以英文原稿为参考以便获得更精准的信息。
- 3.本站提供的产品资料，来自厂商的技术支持或者使用者的心得体会等，其内容可能存在描述上的差异，建议读者做出适当判断。
- 4.如需与我们联系，请发邮件到marketing@iczoom.com，主题请标有“数据手册”字样。

Read Statement

1. The datasheets and other product information on the site are all from network reference or other public materials, and the copyright belongs to the original author and original published source. If readers and copyright owners have any objections, please contact us and we will deal with it in a timely manner.
2. The Chinese datasheets provided on the website is a Chinese translation of the English datasheets. Its purpose is for reader's learning exchange only and do not involve commercial purposes. The translation cannot be automatically updated with the original manuscript, and there may also be improper translations. Readers are advised to use the English manuscript as a reference for more accurate information.
3. All product information provided on the website refer to solutions from manufacturers' technical support or users the contents may have differences in description, and readers are advised to take the original article as the standard.
4. If you have any questions, please contact us at marketing@iczoom.com and mark the subject with "Datasheets" .

features

- 10.7-Gbps Operation
- 116-mW Power Consumption
- Input Offset Cancellation
- High Input Dynamic Range
- Output Disable
- CML Data Outputs
- 2-mV_{p-p} Input Sensitivity
- Loss of Signal Detection
- Single 3.3-V Supply

- Surface Mount Small Footprint 4 mm × 4 mm, 20-Pin QFN Package

applications

- SONET/SDH Transmission Systems at OC-192
- 10-Gbps Fibre Channel Receivers
- 10-Gbps Ethernet Receivers

description

The ONET9901PA is a versatile high-speed limiting amplifier for multiple fiber optic applications with data rates up to 10.7 Gbps.

This device provides a typical gain of about 42 dB, which ensures a fully differential output swing for input signals as low as 2 mV_{p-p}.

The high input signal dynamic range ensures low jitter output signals, even when overdriven with input signal swings as high as 1200 mV_{p-p}.

The ONET9901PA comprises an adjustable loss of signals detection. The threshold voltage can be defined by means of an external resistor.

The ONET9901PA is available in a small footprint 4 mm × 4 mm, 20-pin QFN package.

The ONET9901PA is a power efficient limiting amplifier with power dissipation as low as 116 mW typical from a single 3.3-V supply. The part is characterized for operation from 0°C to 85°C.



Please be aware that an important notice concerning availability, standard warranty, and use in critical applications of Texas Instruments semiconductor products and disclaimers thereto appears at the end of this data sheet.

PRODUCTION DATA information is current as of publication date. Products conform to specifications per the terms of Texas Instruments standard warranty. Production processing does not necessarily include testing of all parameters.



POST OFFICE BOX 655303 • DALLAS, TEXAS 75265

Copyright © 2005, Texas Instruments Incorporated

ONET9901PA 10.7-Gbps LIMITING AMPLIFIER

SLLS601A – MAY 2004 – REVISED OCTOBER 2005

block diagram

A simplified block diagram of the ONET9901PA is shown in Figure 1.

This compact, low power 10.7-Gbps limiting amplifier consists of a high-speed data path with offset cancellation block, a loss of signal detection block, and a bandgap voltage reference and bias current generation block.

The limiting amplifier requires a single 3.3-V supply voltage. All circuit parts are described in detail below.

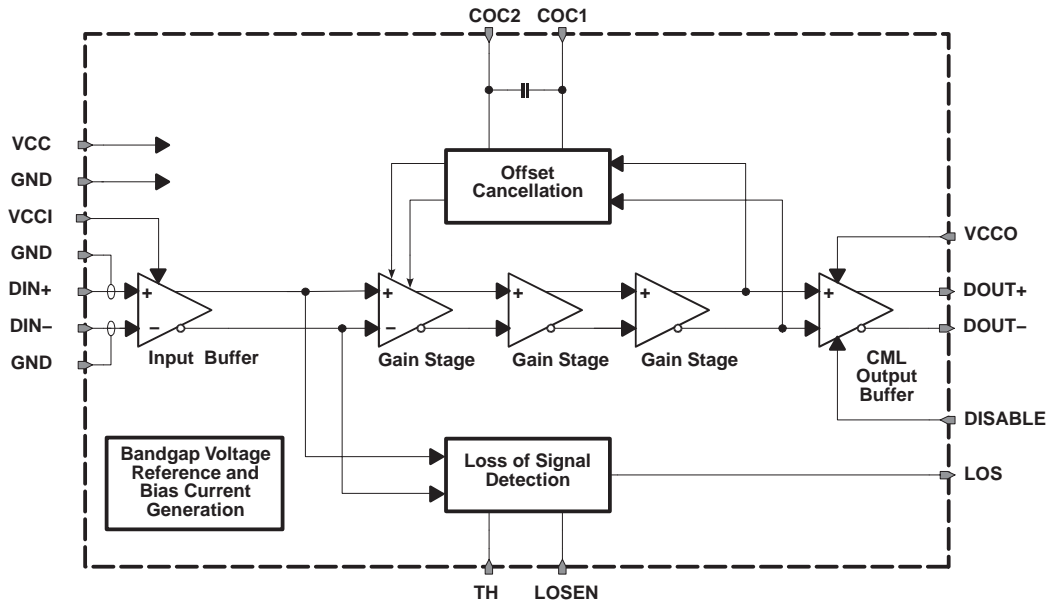

Figure 1. Block Diagram

high-speed data path

The high-speed data signal is applied to the data path by means of the input signal pins DIN+/DIN-. The data path consists of the input stage with $2 \times 50\text{-}\Omega$ on-chip line termination to VCCI, three gain stages, which provide the required typical gain of about 42 dB, and a CML output stage.

Next to the input signal pins shielding ground pins GND are provided. These pins must have a good external ground connection for best performance at low input signal amplitudes.

The amplified data output signal is available at the output pins DOUT+/DOUT-, which provide $2 \times 50\text{-}\Omega$ back-termination to VCCO. The output stage also includes a disable function, controlled by the signal applied to the DISABLE input pin.

An offset cancellation compensates inevitable internal offset voltages and thus ensures proper operation even for small input data signals.

The low frequency cutoff is as low as 42 kHz with the built-in filter capacitor.

For applications, which require even lower cutoff frequencies, an additional external filter capacitor may be connected to the COC1/COC2 pins.

loss of signal and RSSI detection

The output signal of the input buffer is monitored by the loss of signal detection circuitry. This circuit block compares the input signal to a threshold, which can be programmed by means of an external resistor connected to the TH pin. If the input signal falls below the specified threshold, a loss of signal is indicated at the LOS pin.

For use in applications, which do not require a loss of signal function, this circuit block can be shut down by connecting the LOSEN pin to GND.

bandgap voltage and bias generation

The ONET9901PA limiting amplifier is supplied by a single 3.3-V $\pm 10\%$ supply voltage connected to the VCC, VCCI, and VCCO pins. This voltage is referred to ground (GND).

An on-chip bandgap voltage circuitry generates a supply voltage independent reference from which all other internally required voltages and bias currents are derived.

package

For the ONET9901PA a small footprint 4 mm \times 4 mm, 20-pin QFN package is used with a lead pitch of 0,5 mm. The pinout is shown in Figure 2.

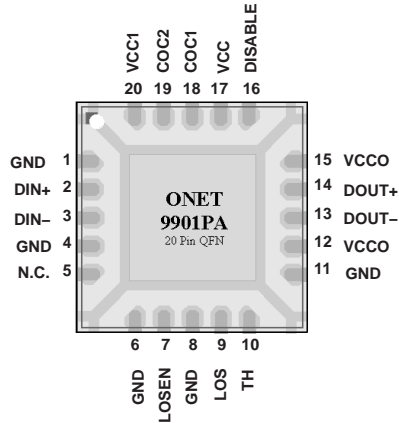

Figure 2. Pinout of ONET9901PA in a 4 mm \times 4 mm 20-Pin QFN Package

ONET9901PA

10.7-Gbps LIMITING AMPLIFIER

SLLS601A – MAY 2004 – REVISED OCTOBER 2005

terminal functions

The following table shows a pin description for the ONET9901PA in a 4 mm x 4 mm 20-pin QFN package.

TERMINAL		TYPE	DESCRIPTION
NAME	NO.		
GND	1, 4, 6, 8, 11, EP	Ground	Circuit ground. The exposed die pad (EP) must be grounded.
DIN+	2	Analog in	Noninverted data input. On-chip 50-Ω terminated to VCCI
DIN-	3	Analog in	Inverted data input. On-chip 50-Ω terminated to VCCI
NC	5		Not connected
LOSEN	7	CMOS in	Enables loss off signal circuitry when set to high level (VCC)
LOS	9	CMOS out	A high level indicates that the input signal amplitude is below the programmed threshold level.
TH	10	Analog in	LOS threshold adjustment with resistor to GND
VCCO	12, 15	Supply	3.3-V ±10% supply voltage for output stage
DOUT-	13	CML out	Inverted data output. On-chip 50-Ω back-terminated to VCCO
DOUT+	14	CML out	Noninverted data output. On-chip 50-Ω back-terminated to VCCO
DISABLE	16	CMOS in	Disables CML output stage when set to high level
VCC	17	Supply	3.3-V ±10% supply voltage
COC1	18	Analog	Offset cancellation filter capacitor terminal 1. Connect an additional filter capacitor between this pin and COC2 (pin 19). To disable the offset cancellation loop, connect COC1 and COC2 (pins 18 and 19).
COC2	19	Analog	Offset cancellation filter capacitor terminal 2. Connect an additional filter capacitor between this pin and COC1 (pin 18). To disable the offset cancellation loop, connect COC1 and COC2 (pins 18 and 19).
VCCI	20	Supply	3.3-V ±10% supply voltage for input stage.

absolute maximum ratings

over operating free-air temperature range unless otherwise noted†

		VALUE	UNIT
V _{CC} , V _{CCI} , V _{CCO}	Supply voltage, See Note 1	-0.3 to 4	V
V _{DIN+} , V _{DIN-}	Voltage at DIN+, DIN-, See Note 1	0.5 to 4	V
V _{TH} , V _{DISABLE} , V _{LOS} , V _{LOSEN} , V _{DOUT+} , V _{DOUT-} , V _{COC1} , V _{COC2}	Voltage at TH, DISABLE, LOS, LOSEN, DOUT+, DOUT-, COC1, COC2, See Note 1	-0.3 to 4	V
V _{COC,DIFF}	Differential voltage between COC1 and COC2	±1	V
V _{DIN,DIFF}	Differential voltage between DIN+ and DIN-	±2.5	V
I _{LOS}	Current into LOS	-1 to 9	mA
I _{DIN+} , I _{DIN-} , I _{DOUT+} , I _{DOUT-}	Continuous current at inputs and outputs	-25 to 25	mA
ESD	ESD rating at all pins except DIN+, DIN-, DOUT+, DOUT-	2	kV (HBM)
ESD	ESD rating at DIN+, DIN-, DOUT+, DOUT-	1	kV (HBM)
T _{J(max)}	Maximum junction temperature	125	°C
T _{stg}	Storage temperature range	-65 to 85	°C
T _A	Characterized free-air operating temperature range	0 to 85	°C
T _L	Lead temperature 1,6 mm (1/16 inch) from case for 10 seconds	260	°C

† Stresses beyond those listed under “absolute maximum ratings” may cause permanent damage to the device. These are stress ratings only, and functional operation of the device at these or any other conditions beyond those indicated under “recommended operating conditions” is not implied. Exposure to absolute-maximum-rated conditions for extended periods may affect device reliability.

NOTE 1: All voltage values are with respect to network ground terminal.



recommended operating conditions

	MIN	TYP	MAX	UNIT
Supply voltage, V_{CC} , V_{CCI} , V_{CCO}	3	3.3	3.6	V
Operating free-air temperature, T_A	0		85	°C

dc electrical characteristics

over recommended operating conditions (unless otherwise noted)

PARAMETER	TEST CONDITIONS	MIN	TYP	MAX	UNIT
V_{CC}, V_{CCI}, V_{CCO} Supply voltage		3	3.3	3.6	V
I_{CC} Supply current	LOSEN = high, DISABLE = low, $V_{TH} = 50 \text{ mV}_{p-p}$		35	55	mA
	LOSEN = low, DISABLE = low		25	35	
V_{OD} Differential data output voltage swing	DISABLE = high		0.25	10	mV_{p-p}
	DISABLE = low	190	240	400	
V_{OC} Common-mode output voltage		$V_{CC} - 0.075$			V
r_o Data output resistance	Single ended		50		Ω
$r_{(IND)}$ Data input resistance	Differential		100		Ω
$V_{(INMIN)}$ Data input sensitivity	$V_{OD(min)} \geq 0.95 \times V_{OD}$ (at $V_{IN} = 10 \text{ mV}$)		2		mV_{p-p}
	BER < 10^{-12} , 2 ²³⁻¹ PRBS, 10.7 Gbps		6		
$V_{(INMAX)}$ Data input overload		1200			mV_{p-p}
CMOS input high voltage	DISABLE, LOSEN	2.1			V
CMOS input low voltage	DISABLE, LOSEN			0.6	V
LOS high voltage		2.4			V
LOS low voltage				0.4	V
LOS hysteresis	$5 \text{ mV}_{p-p} < V_{TH} < 40 \text{ mV}_{p-p}$	2.5	4.5	6.2	dB
V_{TH} LOS assert threshold range			2-50		mV_{p-p}

ac electrical characteristics

over recommended operating conditions (unless otherwise noted) typical operating condition is at $V_{CC} = 3.3 \text{ V}$ and $T_A = 25^\circ\text{C}$

PARAMETER	TEST CONDITIONS	MIN	TYP	MAX	UNIT
BW Small-signal bandwidth			10		GHz
Low frequency -3-dB bandwidth	$C_{OC} = \text{open}$		42	75	kHz
			8		
Data rate		10.7			Gb/s
DJ Deterministic jitter	5 mV_{p-p} , 10-mV_{p-p} input, K28.5 pattern at 10.7 Gbps		5.2	16	ps_{p-p}
	800 mV_{p-p} , 1200-mV_{p-p} input, K28.5 pattern at 10.7 Gbps		1.8	11	
RJ Random jitter	20 mV_{p-p} up to 1200-mV_{p-p} input		0.6	1.1	ps_{RMS}
t_r Output rise time	20% to 80%		20		ps
t_f Output fall time	20% to 80%		20		ps
t_{DIS} Disable response time			20		ns
t_{LOS} LOS assert/deassert time			250		ns

ONET9901PA
10.7-Gbps LIMITING AMPLIFIER

SLLS601A – MAY 2004 – REVISED OCTOBER 2005

APPLICATION INFORMATION

Figure 3 shows the ONET9901PA in a 4 mm × 4 mm 20-pin package connected with an ac-coupled interface to the data signal source as well as to the output load.

Besides the ac-coupling capacitors C₁ through C₄ in the input and output data signal lines, the only required external component is the LOS threshold setting resistor R_{TH}. In addition, an optional external filter capacitor (C_{OC}) may be used if a lower cutoff frequency is desired.

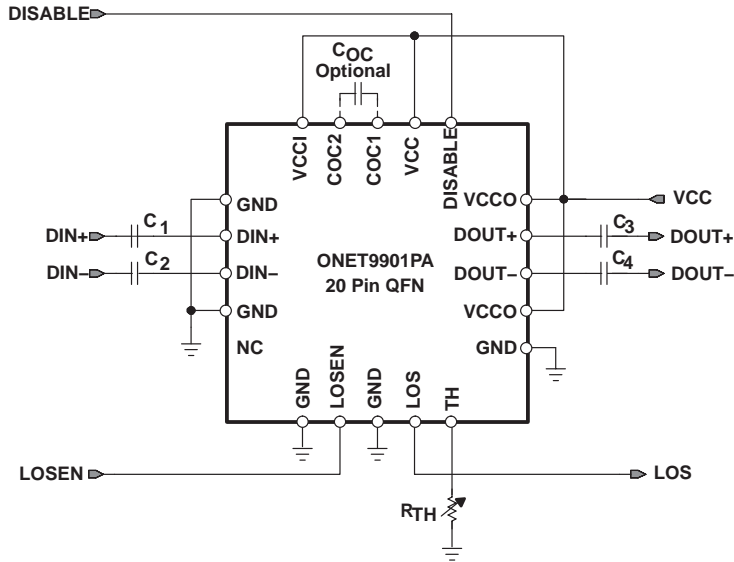

Figure 3. Basic Application Circuit for the ONET9901PA in a 4 mm × 4 mm, 20-Pin QFN Package With AC-Coupled I/Os

PACKAGING INFORMATION

Orderable Device	Status ⁽¹⁾	Package Type	Package Drawing	Pins	Package Qty	Eco Plan ⁽²⁾	Lead/Ball Finish	MSL Peak Temp ⁽³⁾
ONET9901PARGP	NRND	QFN	RGP	20	91	Green (RoHS & no Sb/Br)	CU NIPDAU	Level-2-260C-1 YEAR
ONET9901PARGPG4	NRND	QFN	RGP	20	91	Green (RoHS & no Sb/Br)	CU NIPDAU	Level-2-260C-1 YEAR

⁽¹⁾ The marketing status values are defined as follows:

ACTIVE: Product device recommended for new designs.

LIFEBUY: TI has announced that the device will be discontinued, and a lifetime-buy period is in effect.

NRND: Not recommended for new designs. Device is in production to support existing customers, but TI does not recommend using this part in a new design.

PREVIEW: Device has been announced but is not in production. Samples may or may not be available.

OBsolete: TI has discontinued the production of the device.

⁽²⁾ Eco Plan - The planned eco-friendly classification: Pb-Free (RoHS), Pb-Free (RoHS Exempt), or Green (RoHS & no Sb/Br) - please check <http://www.ti.com/productcontent> for the latest availability information and additional product content details.

TBD: The Pb-Free/Green conversion plan has not been defined.

Pb-Free (RoHS): TI's terms "Lead-Free" or "Pb-Free" mean semiconductor products that are compatible with the current RoHS requirements for all 6 substances, including the requirement that lead not exceed 0.1% by weight in homogeneous materials. Where designed to be soldered at high temperatures, TI Pb-Free products are suitable for use in specified lead-free processes.

Pb-Free (RoHS Exempt): This component has a RoHS exemption for either 1) lead-based flip-chip solder bumps used between the die and package, or 2) lead-based die adhesive used between the die and leadframe. The component is otherwise considered Pb-Free (RoHS compatible) as defined above.

Green (RoHS & no Sb/Br): TI defines "Green" to mean Pb-Free (RoHS compatible), and free of Bromine (Br) and Antimony (Sb) based flame retardants (Br or Sb do not exceed 0.1% by weight in homogeneous material)

⁽³⁾ MSL, Peak Temp. -- The Moisture Sensitivity Level rating according to the JEDEC industry standard classifications, and peak solder temperature.

Important Information and Disclaimer:The information provided on this page represents TI's knowledge and belief as of the date that it is provided. TI bases its knowledge and belief on information provided by third parties, and makes no representation or warranty as to the accuracy of such information. Efforts are underway to better integrate information from third parties. TI has taken and continues to take reasonable steps to provide representative and accurate information but may not have conducted destructive testing or chemical analysis on incoming materials and chemicals. TI and TI suppliers consider certain information to be proprietary, and thus CAS numbers and other limited information may not be available for release.

In no event shall TI's liability arising out of such information exceed the total purchase price of the TI part(s) at issue in this document sold by TI to Customer on an annual basis.

RGP (S-PVQFN-N20)

PLASTIC QUAD FLATPACK NO-LEAD

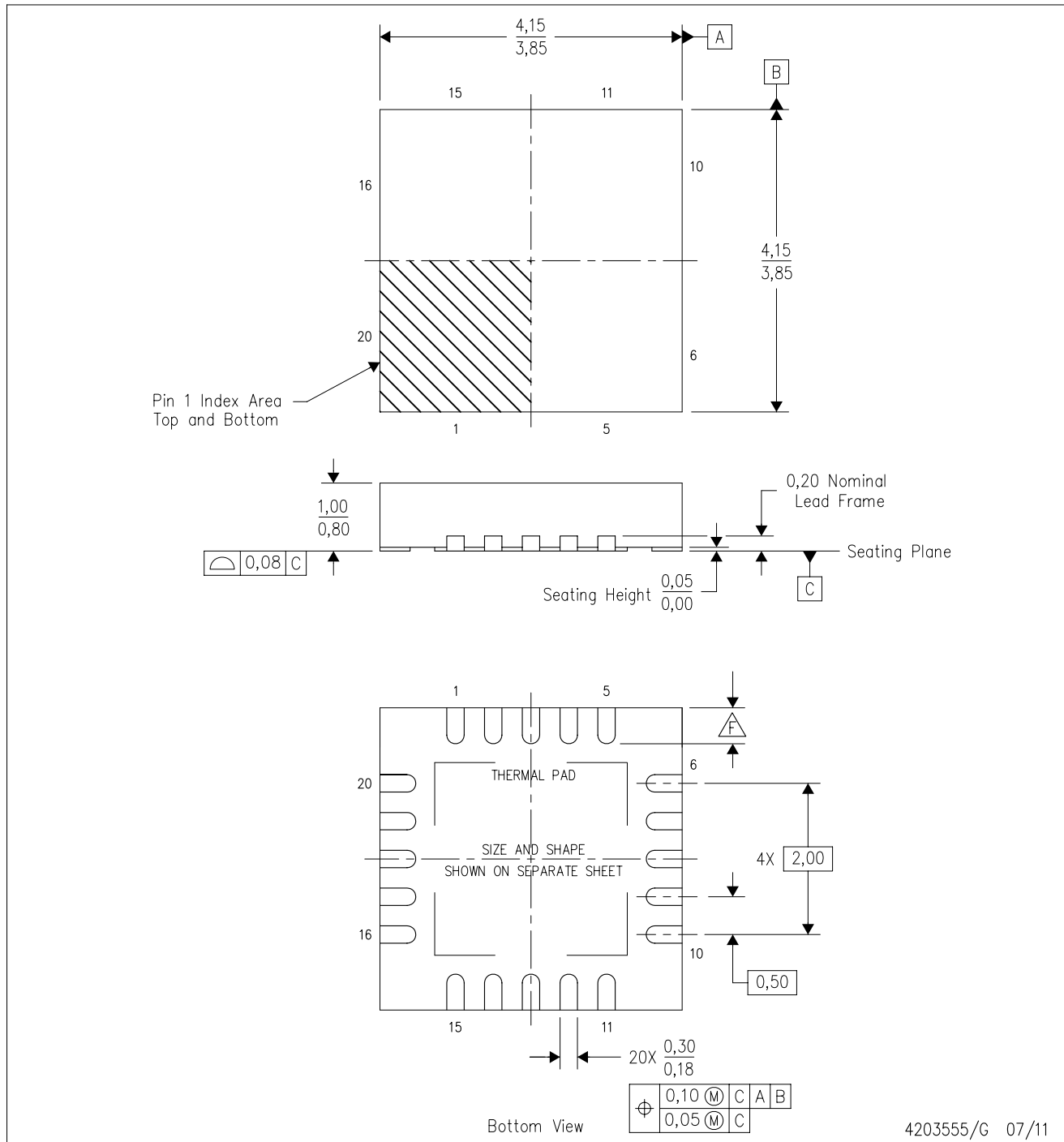

- NOTES:
- All linear dimensions are in millimeters. Dimensioning and tolerancing per ASME Y14.5M-1994.
 - This drawing is subject to change without notice.
 - QFN (Quad Flatpack No-Lead) package configuration.
 - The package thermal pad must be soldered to the board for thermal and mechanical performance.
 - See the additional figure in the Product Data Sheet for details regarding the exposed thermal pad features and dimensions.
- Check thermal pad mechanical drawing in the product datasheet for nominal lead length dimensions.

THERMAL PAD MECHANICAL DATA

RGP (S-PVQFN-N20)

PLASTIC QUAD FLATPACK NO-LEAD

THERMAL INFORMATION

This package incorporates an exposed thermal pad that is designed to be attached directly to an external heatsink. The thermal pad must be soldered directly to the printed circuit board (PCB). After soldering, the PCB can be used as a heatsink. In addition, through the use of thermal vias, the thermal pad can be attached directly to the appropriate copper plane shown in the electrical schematic for the device, or alternatively, can be attached to a special heatsink structure designed into the PCB. This design optimizes the heat transfer from the integrated circuit (IC).

For information on the Quad Flatpack No-Lead (QFN) package and its advantages, refer to Application Report, QFN/SON PCB Attachment, Texas Instruments Literature No. SLUA271. This document is available at www.ti.com.

The exposed thermal pad dimensions for this package are shown in the following illustration.

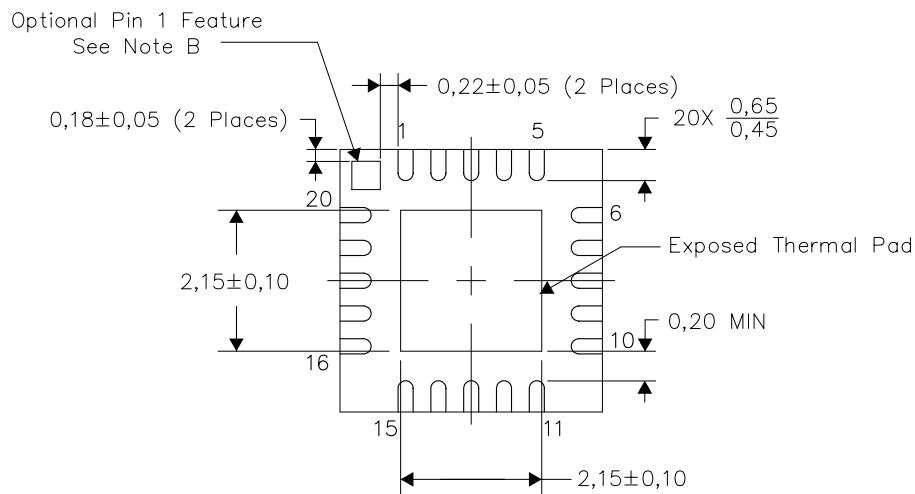

Bottom View

Exposed Thermal Pad Dimensions

4206346-2/W 07/11

NOTES: A. All linear dimensions are in millimeters

- B. The Pin 1 Identification mark is an optional feature that may be present on some devices. In addition, this Pin 1 feature if present is electrically connected to the center thermal pad and therefore should be considered when routing the board layout.

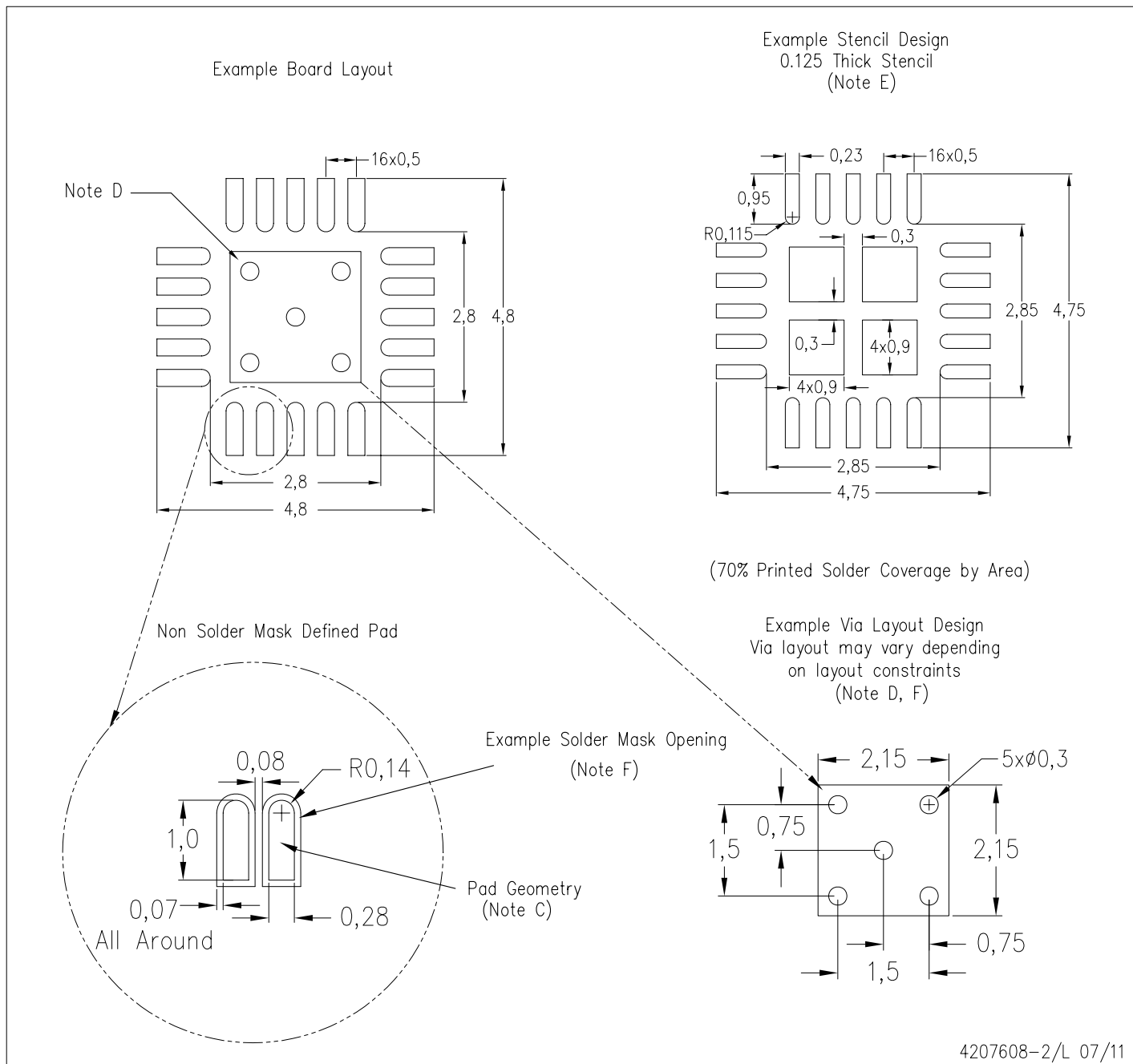

- NOTES:
- All linear dimensions are in millimeters.
 - This drawing is subject to change without notice.
 - Publication IPC-7351 is recommended for alternate designs.
 - This package is designed to be soldered to a thermal pad on the board. Refer to Application Note, Quad Flat-Pack Packages, Texas Instruments Literature No. SLUA271, and also the Product Data Sheets for specific thermal information, via requirements, and recommended board layout. These documents are available at www.ti.com <<http://www.ti.com>>.
 - Laser cutting apertures with trapezoidal walls and also rounding corners will offer better paste release. Customers should contact their board assembly site for stencil design recommendations. Refer to IPC 7525 for stencil design considerations.
 - Customers should contact their board fabrication site for recommended solder mask tolerances and via tenting recommendations for vias placed in the thermal pad.

IMPORTANT NOTICE

Texas Instruments Incorporated and its subsidiaries (TI) reserve the right to make corrections, modifications, enhancements, improvements, and other changes to its products and services at any time and to discontinue any product or service without notice. Customers should obtain the latest relevant information before placing orders and should verify that such information is current and complete. All products are sold subject to TI's terms and conditions of sale supplied at the time of order acknowledgment.

TI warrants performance of its hardware products to the specifications applicable at the time of sale in accordance with TI's standard warranty. Testing and other quality control techniques are used to the extent TI deems necessary to support this warranty. Except where mandated by government requirements, testing of all parameters of each product is not necessarily performed.

TI assumes no liability for applications assistance or customer product design. Customers are responsible for their products and applications using TI components. To minimize the risks associated with customer products and applications, customers should provide adequate design and operating safeguards.

TI does not warrant or represent that any license, either express or implied, is granted under any TI patent right, copyright, mask work right, or other TI intellectual property right relating to any combination, machine, or process in which TI products or services are used. Information published by TI regarding third-party products or services does not constitute a license from TI to use such products or services or a warranty or endorsement thereof. Use of such information may require a license from a third party under the patents or other intellectual property of the third party, or a license from TI under the patents or other intellectual property of TI.

Reproduction of TI information in TI data books or data sheets is permissible only if reproduction is without alteration and is accompanied by all associated warranties, conditions, limitations, and notices. Reproduction of this information with alteration is an unfair and deceptive business practice. TI is not responsible or liable for such altered documentation. Information of third parties may be subject to additional restrictions.

Resale of TI products or services with statements different from or beyond the parameters stated by TI for that product or service voids all express and any implied warranties for the associated TI product or service and is an unfair and deceptive business practice. TI is not responsible or liable for any such statements.

TI products are not authorized for use in safety-critical applications (such as life support) where a failure of the TI product would reasonably be expected to cause severe personal injury or death, unless officers of the parties have executed an agreement specifically governing such use. Buyers represent that they have all necessary expertise in the safety and regulatory ramifications of their applications, and acknowledge and agree that they are solely responsible for all legal, regulatory and safety-related requirements concerning their products and any use of TI products in such safety-critical applications, notwithstanding any applications-related information or support that may be provided by TI. Further, Buyers must fully indemnify TI and its representatives against any damages arising out of the use of TI products in such safety-critical applications.

TI products are neither designed nor intended for use in military/aerospace applications or environments unless the TI products are specifically designated by TI as military-grade or "enhanced plastic." Only products designated by TI as military-grade meet military specifications. Buyers acknowledge and agree that any such use of TI products which TI has not designated as military-grade is solely at the Buyer's risk, and that they are solely responsible for compliance with all legal and regulatory requirements in connection with such use.

TI products are neither designed nor intended for use in automotive applications or environments unless the specific TI products are designated by TI as compliant with ISO/TS 16949 requirements. Buyers acknowledge and agree that, if they use any non-designated products in automotive applications, TI will not be responsible for any failure to meet such requirements.

Following are URLs where you can obtain information on other Texas Instruments products and application solutions:

Products

Audio	www.ti.com/audio
Amplifiers	amplifier.ti.com
Data Converters	dataconverter.ti.com
DLP® Products	www.dlp.com
DSP	dsp.ti.com
Clocks and Timers	www.ti.com/clocks
Interface	interface.ti.com
Logic	logic.ti.com
Power Mgmt	power.ti.com
Microcontrollers	microcontroller.ti.com
RFID	www.ti-rfid.com
RF/IF and ZigBee® Solutions	www.ti.com/lprf

Applications

Communications and Telecom	www.ti.com/communications
Computers and Peripherals	www.ti.com/computers
Consumer Electronics	www.ti.com/consumer-apps
Energy and Lighting	www.ti.com/energy
Industrial	www.ti.com/industrial
Medical	www.ti.com/medical
Security	www.ti.com/security
Space, Avionics and Defense	www.ti.com/space-avionics-defense
Transportation and Automotive	www.ti.com/automotive
Video and Imaging	www.ti.com/video
Wireless	www.ti.com/wireless-apps

TI E2E Community Home Page

e2e.ti.com

Mailing Address: Texas Instruments, Post Office Box 655303, Dallas, Texas 75265
Copyright © 2011, Texas Instruments Incorporated