

阅读申明

- 1.本站收集的数据手册和产品资料都来自互联网，版权归原作者所有。如读者和版权方有任何异议请及时告之，我们将妥善解决。
- 2.本站提供的中文数据手册是英文数据手册的中文翻译，其目的是协助用户阅读，该译文无法自动跟随原稿更新，同时也可能存在翻译上的不当。建议读者以英文原稿为参考以便获得更精准的信息。
- 3.本站提供的产品资料，来自厂商的技术支持或者使用者的心得体会等，其内容可能存在描述上的差异，建议读者做出适当判断。
- 4.如需与我们联系，请发邮件到marketing@iczoom.com，主题请标有“数据手册”字样。

Read Statement

1. The datasheets and other product information on the site are all from network reference or other public materials, and the copyright belongs to the original author and original published source. If readers and copyright owners have any objections, please contact us and we will deal with it in a timely manner.
2. The Chinese datasheets provided on the website is a Chinese translation of the English datasheets. Its purpose is for reader's learning exchange only and do not involve commercial purposes. The translation cannot be automatically updated with the original manuscript, and there may also be improper translations. Readers are advised to use the English manuscript as a reference for more accurate information.
3. All product information provided on the website refer to solutions from manufacturers' technical support or users the contents may have differences in description, and readers are advised to take the original article as the standard.
4. If you have any questions, please contact us at marketing@iczoom.com and mark the subject with "Datasheets" .

S1D13A05 LCD/USB Companion Chip

February 2012

The S1D13A05 is an LCD/USB solution designed for seamless connection to a wide variety of microprocessors. The S1D13A05 integrates a USB slave controller and an LCD graphics controller with an embedded 256K byte SRAM display buffer. The LCD controller supports all standard panel types and multiple TFT types eliminating the need for an external timing control IC. The S1D13A05 includes a Hardware Acceleration Engine to greatly improve screen drawing functions and the built-in USB controller provides revision 1.1 compliance for applications requiring a USB client. This high level of integration provides a low cost, low power, single chip solution to meet the demands of embedded markets requiring USB client support, such as Mobile Communications devices and Palm-size PCs.

The S1D13A05 utilizes a guaranteed low-latency CPU architecture that provides support for microprocessors without READY/WAIT# handshaking signals. The 32-bit internal data path, write buffer and the Hardware Acceleration Engine provide high performance bandwidth into display memory allowing for fast display updates.

Additionally, products requiring a rotated display can take advantage of the SwivelView™ feature which provides hardware rotation of the display memory transparent to the software application. The S1D13A05 also provides support for “Picture-in-Picture Plus” (a variable size Overlay window).

The S1D13A05, with its integrated USB client, provides impressive support for Palm OS® handhelds. However, its impartiality to CPU type or operating system makes it an ideal display solution for a wide variety of applications.

n FEATURES

- Embedded 256KB Display Buffer.
- Low Operating Voltage.
- Low-latency CPU interface.
- Direct support for multiple CPU types.
- Programmable resolutions and color depths.
- Passive LCD support.
- Active Matrix LCD support.
- Extended TFT interfaces (Type 2, 3, 4).
- ‘Direct’ Sharp HR-TFT support (including Mode 2).
- ‘Direct’ Casio TFT support.
- USB Client, Revision 1.1 compliant.
- SwivelView™ (90°, 180°, 270° hardware rotation of displayed image).
 - (Patent # 5,734,875 - Patent # 5,956,049 - Patent #6,262,751)
- “Picture-in-Picture Plus”.
- Pixel Doubling.
- Hardware Acceleration Engine.
- Software Initiated Power Save Mode.
- 48MHz crystal for USBCLK.
- Software Video Invert.
- 121-pin PFBGA package.



n SYSTEM BLOCK DIAGRAM

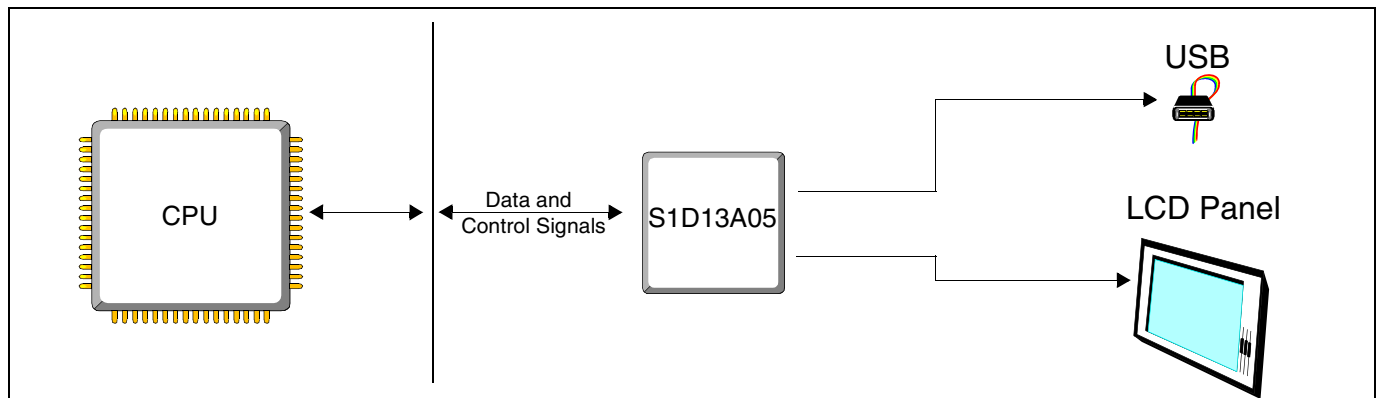

S1D13A05

DESCRIPTION

Memory Interface

- Embedded 256K byte SRAM display buffer.

CPU Interface

- 'Fixed' low-latency CPU access times.
- Direct support for:
 - Hitachi SH-4 / SH-3.
 - Motorola M68xxx (REDCAP2, DragonBall, ColdFire).
 - Motorola Dragonball SZ support (66MHz)
 - MPU bus interface with programmable READY.

Integrated USB Features

- USB Client, Revision 1.1 Compliant.

Power Down Modes

- Software Initiated Power Save Mode.

Operating Voltage

- $CORE_{VDD}$ 2.0 ± 10% volts or 2.5 ± 10% volts.
- IO_{VDD} 3.3 ± 10% volts.

Clock Source

- Three independent clock inputs including dedicated USB clock (single clock possible if USB not required).
- 48MHz crystal oscillator for USBCLK.

Package

- 121-pin PFBGA

Integrated LCD Controller Features

- 1/2/4/8/16 bit-per-pixel (bpp) support.
- Up to 64 gray shades on monochrome passive panels.
- Up to 64K colors on passive/active matrix panels.
- Single-panel, single-drive passive displays.
- 4/8-bit monochrome and 4/8/16-bit color interfaces.
- 9/12/18-bit Active matrix TFT interface.
- 'Direct support for multiple TFT interfaces (Epson, Sharp, Type 2, 3, 4, external timing IC not required).
- SwivelView: hardware rotation by 90°, 180°, 270°.
- "Picture-in-Picture Plus": displays a variable size window overlaid over background image.
- Pixel Doubling: horizontal and vertical resolutions can be doubled without any additional memory.
- Software video invert.
- Typical resolutions supported:
 - 320x320 @ 16bpp
 - 160x160 @ 16bpp (2 pages)
 - 160x240 @ 16bpp
- 2D BitBLT Engine.

Write BLT	Transparent Write BLT
Move BLT	Transparent Move BLT
Solid Fill BLT	Read BLT
Pattern Fill	Color Expansion BLT
Move BLT with Color Expansion	

CONTACT YOUR SALES REPRESENTATIVE FOR THESE COMPREHENSIVE DESIGN TOOLS

- S1D13A05 Technical Manual
- S5U13A05 Evaluation Boards
- CPU Independent Software Utilities
- Palm OS® Hardware Abstraction Layer
- Windows® CE Display Driver
- VXWorks® Tornado™ Display Driver

Japan

Seiko Epson Corporation
 IC International Sales Group
 421-8, Hino, Hino-shi
 Tokyo 191-8501, Japan
 Tel: 042-587-5812
 Fax: 042-587-5564
<http://www.epson.co.jp/>

Hong Kong

Epson Hong Kong Ltd.
 20/F., Harbour Centre
 25 Harbour Road
 Wanchai, Hong Kong
 Tel: 2585-4600
 Fax: 2827-4346
<http://www.epson.com.hk/>

North America

Epson Electronics America, Inc.
 214 Devon Drive
 San Jose, CA 95112, USA
 Tel: (800) 228-3964
 Fax: (408) 922-0238
<http://www.eea.epson.com/>

Europe

Epson Europe Electronics GmbH
 Riesstrasse 15
 80992 Munich, Germany
 Tel: 089-14005-0
 Fax: 089-14005-110
<http://www.epson-electronics.de/>

Taiwan

Epson Taiwan Technology & Trading Ltd.
 14F, No. 7
 Song Ren Road
 Taipei 110
 Tel: 02-8786-6688
 Fax: 02-8786-6677
<http://www.epson.com.tw/>

Singapore

Epson Singapore Pte Ltd
 1 HarbourFront Place #03-02
 HarbourFront Tower One
 Singapore, 098633
 Tel: (65) 6586-5500
 Fax: (65) 6271-3182
<http://www.epson.com.sg/>

© SEIKO EPSON CORPORATION 2001-2012. All rights reserved.
 Information in this document is subject to change without notice. You may download and use this document, but only for your own use in evaluating Seiko Epson/EPSON products. You may not modify the document. Epson Research and Development, Inc. disclaims any representation that the contents of this document are accurate or current. The Programs/Technologies described in this document may contain material protected under U.S. and/or International Patent laws. EPSON is a registered trademark of Seiko Epson Corporation. Palm Computing is a registered trademark and the Palm OS platform Platinum logo is a trademark of Palm Computing, Inc., 3Com or its subsidiaries. Microsoft, Windows, and the Windows Embedded Partner Logo are registered trademarks of Microsoft Corporation. All other trademarks are the property of their respective owners.