

阅读申明

- 1.本站收集的数据手册和产品资料都来自互联网，版权归原作者所有。如读者和版权方有任何异议请及时告之，我们将妥善解决。
- 2.本站提供的中文数据手册是英文数据手册的中文翻译，其目的是协助用户阅读，该译文无法自动跟随原稿更新，同时也可能存在翻译上的不当。建议读者以英文原稿为参考以便获得更精准的信息。
- 3.本站提供的产品资料，来自厂商的技术支持或者使用者的心得体会等，其内容可能存在描述上的差异，建议读者做出适当判断。
- 4.如需与我们联系，请发邮件到marketing@iczoom.com，主题请标有“数据手册”字样。

Read Statement

1. The datasheets and other product information on the site are all from network reference or other public materials, and the copyright belongs to the original author and original published source. If readers and copyright owners have any objections, please contact us and we will deal with it in a timely manner.
2. The Chinese datasheets provided on the website is a Chinese translation of the English datasheets. Its purpose is for reader's learning exchange only and do not involve commercial purposes. The translation cannot be automatically updated with the original manuscript, and there may also be improper translations. Readers are advised to use the English manuscript as a reference for more accurate information.
3. All product information provided on the website refer to solutions from manufacturers' technical support or users the contents may have differences in description, and readers are advised to take the original article as the standard.
4. If you have any questions, please contact us at marketing@iczoom.com and mark the subject with "Datasheets" .

Structure : Silicon Monolithic Integrated Circuit

Product name : Dual Video Amplifier

Type : **BD7628F**

Package : SOP8

Features : 1) Wide operating voltage range
2) 75Ω video line driven
3) Low supply current

○Absolute Maximum Ratings (Ta=25°C)

Parameter	Symbol	Rating	Unit
Positive supply voltage	VCC	+10.0	V
Negative supply voltage	VEE	-10.0	V
Power dissipation	Pd	690*1	mW
Input voltage range	V _{IN}	VEE-0.2V ~ VCC+0.2V	V
Operating temperature	Topr	-40°C~+85°C	°C
Storage temperature	Tstg	-55°C~+150°C	°C

*1 For operation above 25°C free-air temperature, power dissipation is decreasing 4.0mW/°C in case mounting the ROHM standard application board (70mm × 70mm × 1.6mm)

○Operating Condition (Ta=25°C)

Parameter	Symbol	Min	Typ	Max	Unit
Positive supply voltage	VCC	+2.0	+5.0	+6.0	V
Negative supply voltage	VEE	-6.0	-5.0	-2.0	V

* This product is not designed for protection against radioactive rays.

○ External dimensions and label codes

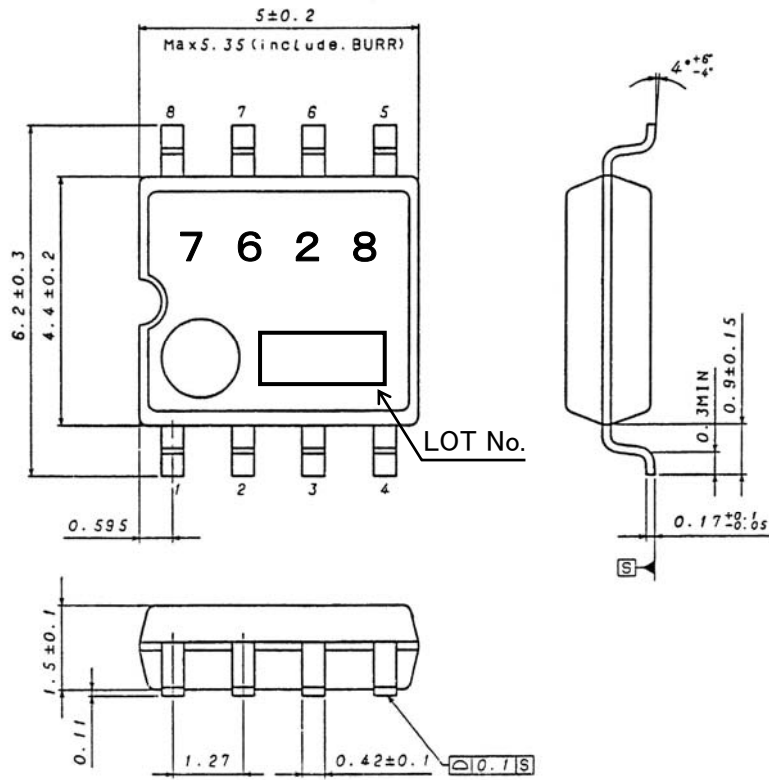

SOP8 (UNIT:mm)

○ Block diagram

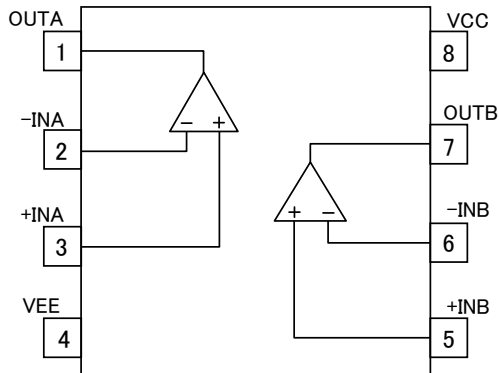

○ Pin number and Pin name

Pin NO.	Pin name	Pin NO.	Pin name
1	OUTA	5	VCC
2	-INA	6	OUTB
3	+INA	7	-INB
4	VEE	8	+INB

○ Electrical characteristics (Unless otherwise specified, $T_a = 25^\circ\text{C}$, $V_{CC} = 5.0\text{V}$, $V_{EE} = -5.0\text{V}$)

Parameter	Symbol	Min.	Typ.	Max.	Unit	Conditions
Circuit current	I_{CC}	-	16.7	23.0	mA	No Signal
Input bias current	I_{IB}	-	-	6	μA	$V_{in} = 0.0\text{V}$
Maximum output voltage	V_{OM}	5.0	5.7	-	V_{pp}	DC Voltage
Voltage gain	G_V	5.6	5.9	6.2	dB	$V_{in} = 1.0\text{V}_{pp}$, $f = 1\text{MHz}$
Frequency characteristics	G_F	-2.0	-0.1	1.0	dB	$V_{in} = 1.0\text{V}_{pp}$, $f = 1\text{MHz}/10\text{MHz}$
Cross talk	C_T	-	-63	-50	dB	$V_{in} = 1.0\text{V}_{pp}$, $f = 4.43\text{MHz}$

○ Test Circuit Diagrams

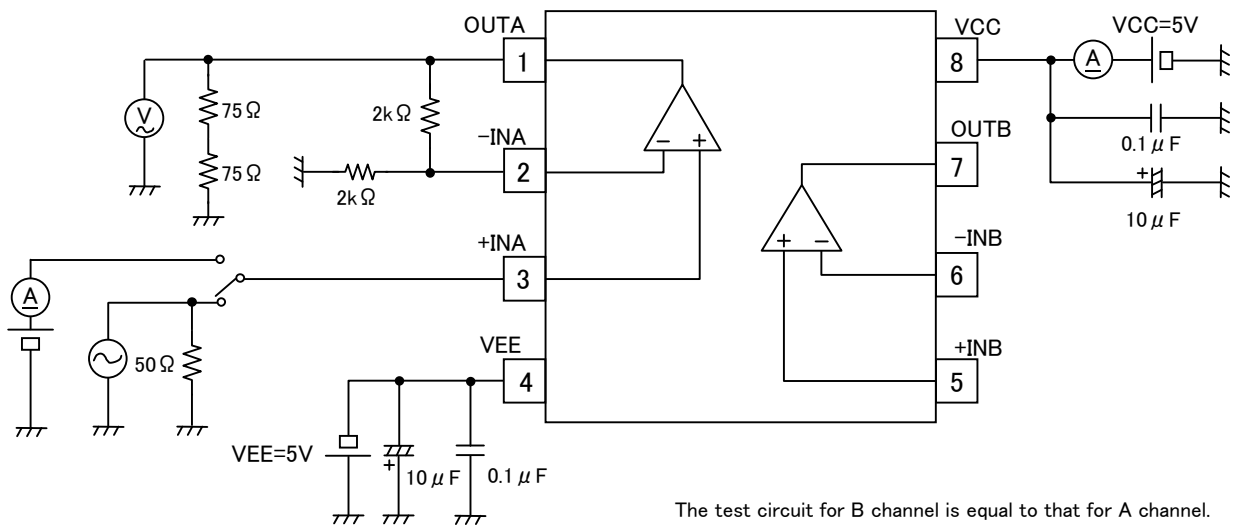

● Cautions for use

(1) Absolute maximum ratings

If the absolute maximum ratings for applied voltage and/or operation temperature are exceeded, LSI damage may result. Therefore, do not apply voltage or use in a temperature that exceeds these absolute maximum ratings. If it is possible that absolute maximum ratings will be exceeded, use a physical safety device such as a fuse and make sure that no conditions that might exceed the absolute maximum ratings will be applied to the LSI IC.

(2) Thermal design

The thermal design should be done using an ample margin that takes into consideration the allowable dissipation under actual use conditions.

(3) Shorts between pins and mounting errors

When mounting LSI ICs onto the circuit board, make sure each LSI's orientation and position is correct. The ICs may become damaged if they are not mounted correctly when the power is turned on. Similarly, damage may also result if a short occurs, such as when a foreign object is positioned between pins in an IC, or between a pin and a power supply or GND connection.

(4) Operation in strong electromagnetic field

When used within a strong electromagnetic field, evaluate carefully to avoid the risk of operation faults.

Notes

No copying or reproduction of this document, in part or in whole, is permitted without the consent of ROHM Co.,Ltd.

The content specified herein is subject to change for improvement without notice.

The content specified herein is for the purpose of introducing ROHM's products (hereinafter "Products"). If you wish to use any such Product, please be sure to refer to the specifications, which can be obtained from ROHM upon request.

Examples of application circuits, circuit constants and any other information contained herein illustrate the standard usage and operations of the Products. The peripheral conditions must be taken into account when designing circuits for mass production.

Great care was taken in ensuring the accuracy of the information specified in this document. However, should you incur any damage arising from any inaccuracy or misprint of such information, ROHM shall bear no responsibility for such damage.

The technical information specified herein is intended only to show the typical functions of and examples of application circuits for the Products. ROHM does not grant you, explicitly or implicitly, any license to use or exercise intellectual property or other rights held by ROHM and other parties. ROHM shall bear no responsibility whatsoever for any dispute arising from the use of such technical information.

The Products specified in this document are intended to be used with general-use electronic equipment or devices (such as audio visual equipment, office-automation equipment, communication devices, electronic appliances and amusement devices).

The Products specified in this document are not designed to be radiation tolerant.

While ROHM always makes efforts to enhance the quality and reliability of its Products, a Product may fail or malfunction for a variety of reasons.

Please be sure to implement in your equipment using the Products safety measures to guard against the possibility of physical injury, fire or any other damage caused in the event of the failure of any Product, such as derating, redundancy, fire control and fail-safe designs. ROHM shall bear no responsibility whatsoever for your use of any Product outside of the prescribed scope or not in accordance with the instruction manual.

The Products are not designed or manufactured to be used with any equipment, device or system which requires an extremely high level of reliability the failure or malfunction of which may result in a direct threat to human life or create a risk of human injury (such as a medical instrument, transportation equipment, aerospace machinery, nuclear-reactor controller, fuel-controller or other safety device). ROHM shall bear no responsibility in any way for use of any of the Products for the above special purposes. If a Product is intended to be used for any such special purpose, please contact a ROHM sales representative before purchasing.

If you intend to export or ship overseas any Product or technology specified herein that may be controlled under the Foreign Exchange and the Foreign Trade Law, you will be required to obtain a license or permit under the Law.



Thank you for your accessing to ROHM product informations.
More detail product informations and catalogs are available, please contact us.

ROHM Customer Support System

<http://www.rohm.com/contact/>