

阅读申明

- 1.本站收集的数据手册和产品资料都来自互联网，版权归原作者所有。如读者和版权方有任何异议请及时告之，我们将妥善解决。
- 2.本站提供的中文数据手册是英文数据手册的中文翻译，其目的是协助用户阅读，该译文无法自动跟随原稿更新，同时也可能存在翻译上的不当。建议读者以英文原稿为参考以便获得更精准的信息。
- 3.本站提供的产品资料，来自厂商的技术支持或者使用者的心得体会等，其内容可能存在描述上的差异，建议读者做出适当判断。
- 4.如需与我们联系，请发邮件到marketing@iczoom.com，主题请标有“数据手册”字样。

Read Statement

1. The datasheets and other product information on the site are all from network reference or other public materials, and the copyright belongs to the original author and original published source. If readers and copyright owners have any objections, please contact us and we will deal with it in a timely manner.
2. The Chinese datasheets provided on the website is a Chinese translation of the English datasheets. Its purpose is for reader's learning exchange only and do not involve commercial purposes. The translation cannot be automatically updated with the original manuscript, and there may also be improper translations. Readers are advised to use the English manuscript as a reference for more accurate information.
3. All product information provided on the website refer to solutions from manufacturers' technical support or users the contents may have differences in description, and readers are advised to take the original article as the standard.
4. If you have any questions, please contact us at marketing@iczoom.com and mark the subject with "Datasheets" .



ON Semiconductor®

<http://onsemi.com>

LA78041

Monolithic Linear IC

TV and CRT Display Vertical Output IC with Bus Control Support

Overview

The LA78041 is a vertical deflection output IC for high image quality TV and CRT displays that supports the use of a bus control system signal-processing IC. The sawtooth waveform from the bus control system signal-processing IC can directly drive the deflection yoke (including the DC component). Color TV vertical deflection system adjustment functions can be controlled over a bus system by connecting the LA78041 to a our company LA768X series or LA769XX series bus control system signal-processing IC.

Since the LA78041 provides a maximum deflection current of 2.2Ap-p, it is optimal for large size CRTs.

Functions

- Low power operation achieved by using integrated charge pump circuit.
- Vertical output circuit.
- Thermal protection circuit.
- Excellent crossover characteristics.
- Supports DC coupling.

Specifications

Maximum Ratings at Ta = 25°C

Parameter	Symbol	Conditions	Ratings	Unit
Pump-up block supply voltage	+B2 max		34	V
Output block supply voltage	+B6 max		70	V
Allowable power dissipation	Pd max	Mounted on an arbitrarily large heat sink.	9	W
Deflection output current	I5 max		-1.5 to +1.5	Ap-o
Thermal resistance	θj-c		3	°C/W
Operating temperature	Topr		-20 to +85	°C
Storage temperature	Tstg		-40 to +150	°C

Stresses exceeding Maximum Ratings may damage the device. Maximum Ratings are stress ratings only. Functional operation above the Recommended Operating Conditions is not implied. Extended exposure to stresses above the Recommended Operating Conditions may affect device reliability.

LA78041

Operating Conditions at $T_a = 25^\circ\text{C}$

Parameter	Symbol	Conditions	Ratings	Unit
Recommended supply voltage	+B2		24	V
Operating supply voltage range	+B2op		16 to 33	V
Deflection output current	I _{5p-p}		To 2.2	Ap-p

Operating Characteristics at $T_a = 25^\circ\text{C}$, +B2 = 24V

Parameter	Symbol	Conditions	Ratings			Unit
			min	typ	max	
Deflection output saturation voltage (lower)	V _{sat5-4}	I ₅ = 1.1A			1.3	V
Deflection output saturation voltage (upper)	V _{sat6-5}	I ₅ = -1.1A			3.2	V
Pump-up charge saturation voltage	V _{sat3-4}	I ₃ = 20mA			1.8	V
Pump-up discharge saturation voltage	V _{sat2-3}	I ₃ = -1.1A			3.0	V
Idling current	I _{dl}		20		50	mA
Midpoint voltage	V _{mid}		11.0	12.0	13.0	V

Note: Current flowing into the IC is positive (+) and current flowing out is negative (-).

Package Dimensions

unit : mm

3286

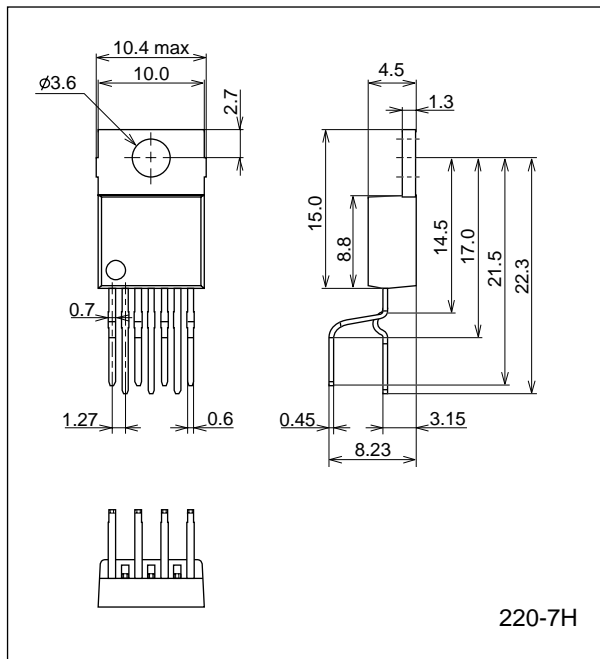

LA78041

Block Diagram

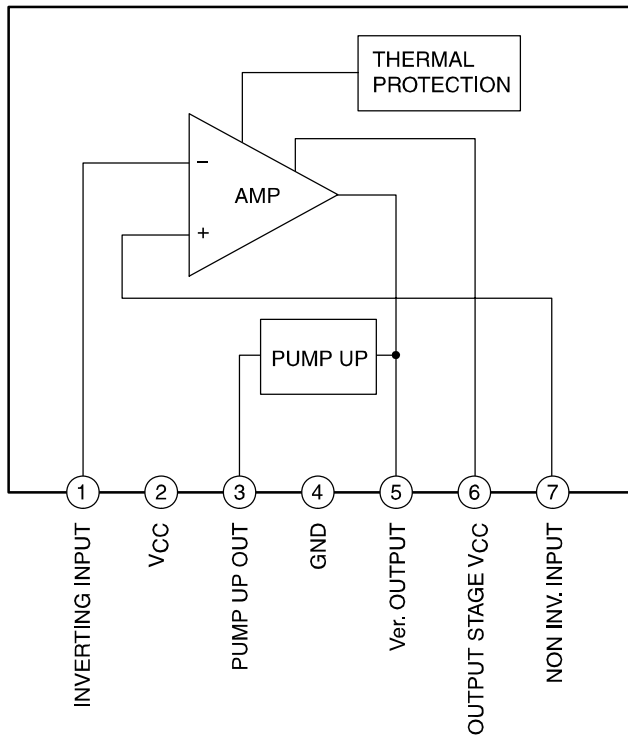

ILA07076

Application Circuit Example 1 (Single power supply)

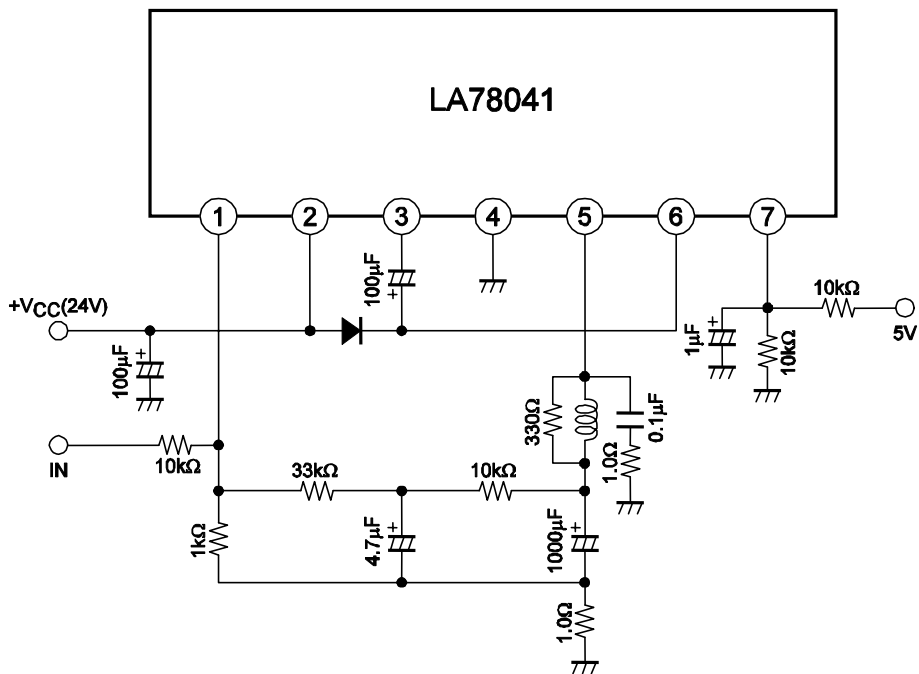

LA78041

Application Circuit Example 2 (Dual power supply)

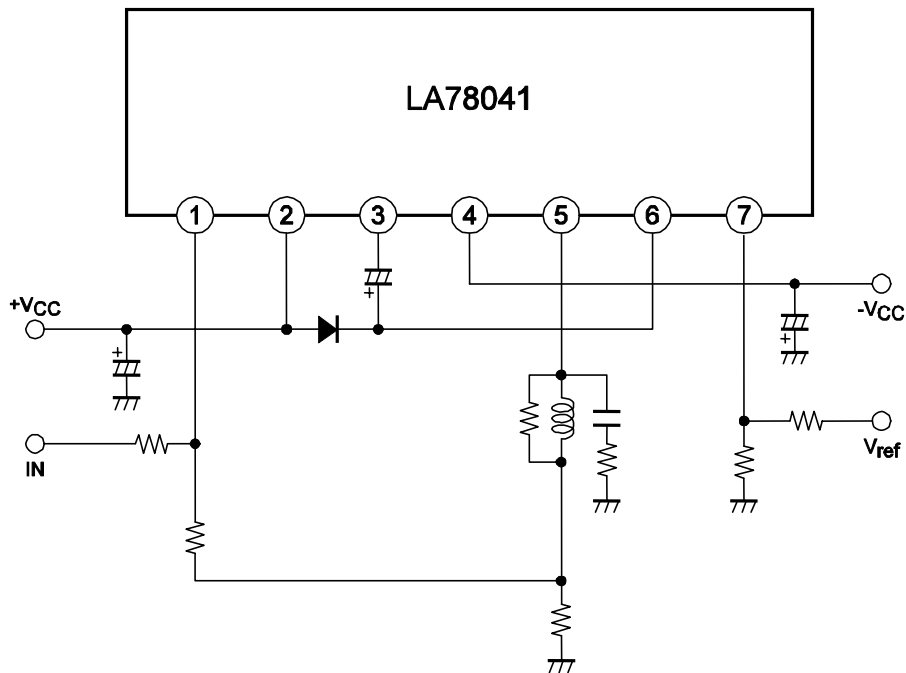

ON Semiconductor and the ON logo are registered trademarks of Semiconductor Components Industries, LLC (SCILLC). SCILLC owns the rights to a number of patents, trademarks, copyrights, trade secrets, and other intellectual property. A listing of SCILLC's product/patent coverage may be accessed at www.onsemi.com/site/pdf/Patent-Marking.pdf. SCILLC reserves the right to make changes without further notice to any products herein. SCILLC makes no warranty, representation or guarantee regarding the suitability of its products for any particular purpose, nor does SCILLC assume any liability arising out of the application or use of any product or circuit, and specifically disclaims any and all liability, including without limitation special, consequential or incidental damages. "Typical" parameters which may be provided in SCILLC data sheets and/or specifications can and do vary in different applications and actual performance may vary over time. All operating parameters, including "Typicals" must be validated for each customer application by customer's technical experts. SCILLC does not convey any license under its patent rights nor the rights of others. SCILLC products are not designed, intended, or authorized for use as components in systems intended for surgical implant into the body, or other applications intended to support or sustain life, or for any other application in which the failure of the SCILLC product could create a situation where personal injury or death may occur. Should Buyer purchase or use SCILLC products for any such unintended or unauthorized application, Buyer shall indemnify and hold SCILLC and its officers, employees, subsidiaries, affiliates, and distributors harmless against all claims, costs, damages, and expenses, and reasonable attorney fees arising out of, directly or indirectly, any claim of personal injury or death associated with such unintended or unauthorized use, even if such claim alleges that SCILLC was negligent regarding the design or manufacture of the part. SCILLC is an Equal Opportunity/Affirmative Action Employer. This literature is subject to all applicable copyright laws and is not for resale in any manner.