

阅读申明

- 1.本站收集的数据手册和产品资料都来自互联网，版权归原作者所有。如读者和版权方有任何异议请及时告之，我们将妥善解决。
- 2.本站提供的中文数据手册是英文数据手册的中文翻译，其目的是协助用户阅读，该译文无法自动跟随原稿更新，同时也可能存在翻译上的不当。建议读者以英文原稿为参考以便获得更精准的信息。
- 3.本站提供的产品资料，来自厂商的技术支持或者使用者的心得体会等，其内容可能存在描述上的差异，建议读者做出适当判断。
- 4.如需与我们联系，请发邮件到marketing@iczoom.com，主题请标有“数据手册”字样。

Read Statement

1. The datasheets and other product information on the site are all from network reference or other public materials, and the copyright belongs to the original author and original published source. If readers and copyright owners have any objections, please contact us and we will deal with it in a timely manner.
2. The Chinese datasheets provided on the website is a Chinese translation of the English datasheets. Its purpose is for reader's learning exchange only and do not involve commercial purposes. The translation cannot be automatically updated with the original manuscript, and there may also be improper translations. Readers are advised to use the English manuscript as a reference for more accurate information.
3. All product information provided on the website refer to solutions from manufacturers' technical support or users the contents may have differences in description, and readers are advised to take the original article as the standard.
4. If you have any questions, please contact us at marketing@iczoom.com and mark the subject with "Datasheets" .

HEX BUFFER/CONVERTER (NON INVERTING)

- PROPAGATION DELAY TIME:
 $t_{PD} = 50\text{ns}$ (Typ.) at $V_{DD} = 10\text{V}$ $C_L = 50\text{pF}$
- HIGH TO LOW LEVEL LOGIC CONVERSION
- MULTIPLEXER: 1 TO 6 OR 6 TO 1
- HIGH "SINK" AND "SOURCE" CURRENT CAPABILITY
- QUIESCENT CURRENT SPECIFIED UP TO 20V
- 5V, 10V AND 15V PARAMETRIC RATINGS
- INPUT LEAKAGE CURRENT
 $I_l = 100\text{nA}$ (MAX) AT $V_{DD} = 18\text{V}$ $T_A = 25^\circ\text{C}$
- 100% TESTED FOR QUIESCENT CURRENT
- MEETS ALL REQUIREMENTS OF JEDEC JESD13B "STANDARD SPECIFICATIONS FOR DESCRIPTION OF B SERIES CMOS DEVICES"

DESCRIPTION

The HCF4010B is a monolithic integrated circuit fabricated in Metal Oxide Semiconductor technology available in DIP and SOP packages.

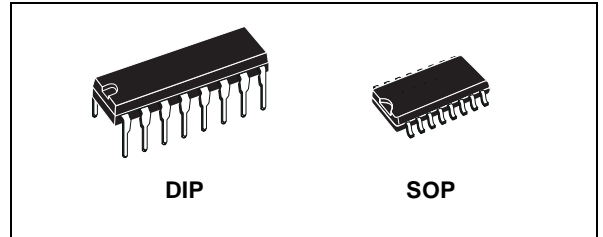

Table 1: Order Codes

PACKAGE	TUBE	T & R
DIP	HCF4010BEY	
SOP	HCF4010BM1	HCF4010M013TR

It is a non inverting Hex Buffer/Converter and can be used as CMOS to TTL logic level converter as current "sink" or "source" driver or as multiplexer (1 to 6). It is a preferred replacement of HCF4050B in buffer applications.

Figure 1: Pin Connection

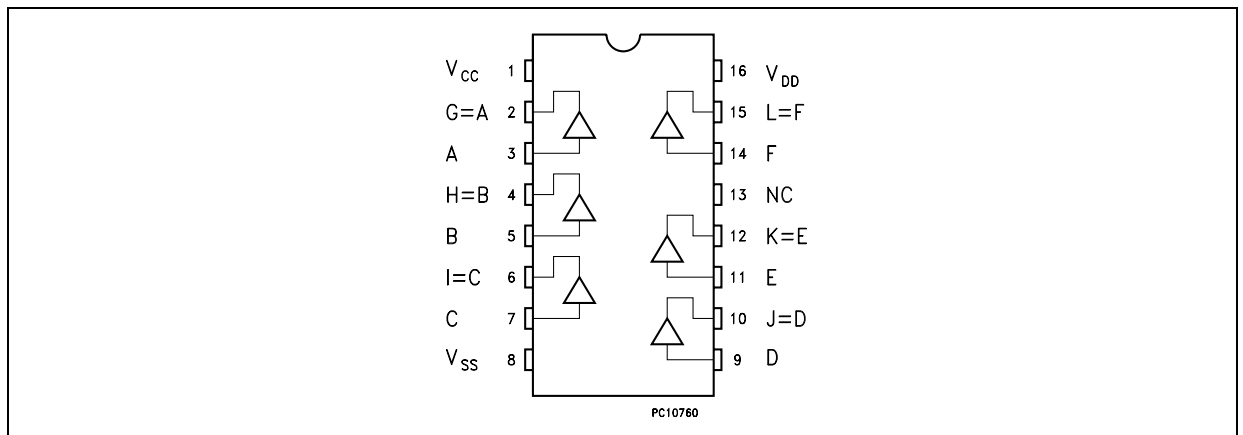

Figure 2: Input Equivalent Circuit

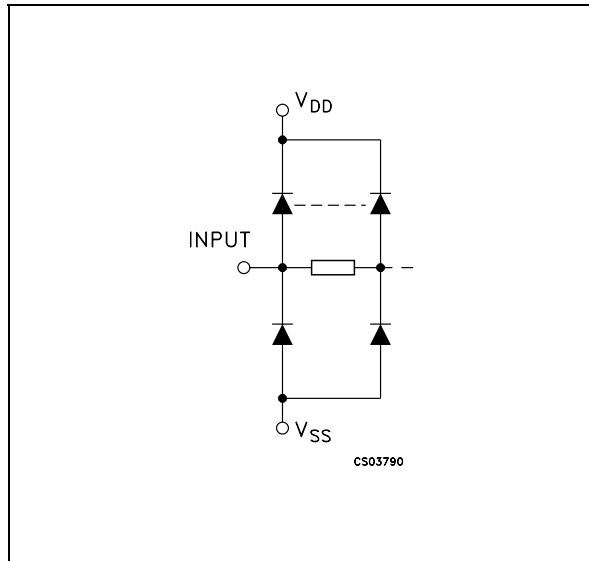

Table 2: Pin Description

PIN N°	SYMBOL	NAME AND FUNCTION
3, 5, 7, 9, 11, 14	A, B, C, D, E, F	Data Inputs
2, 4, 6, 10, 12, 15	G, H, I, J, K, L	Data Outputs
13	NC	Not Connected
1	V _{CC}	Positive Supply Voltage
8	V _{SS}	Negative Supply Voltage
16	V _{DD}	Positive Supply Voltage

Table 3: Truth Table

INPUTS	OUTPUTS
A, B, C, D, E, F	G, H, I, J, K, L
L	L
H	H

Table 4: Absolute Maximum Ratings

Symbol	Parameter	Value	Unit
V _{DD}	Supply Voltage	-0.5 to +22	V
V _I	DC Input Voltage	-0.5 to V _{DD} + 0.5	V
I _I	DC Input Current	± 10	mA
P _D	Power Dissipation per Package	200	mW
	Power Dissipation per Output Transistor	100	mW
T _{op}	Operating Temperature	-55 to +125	°C
T _{stg}	Storage Temperature	-65 to +150	°C

Absolute Maximum Ratings are those values beyond which damage to the device may occur. Functional operation under these conditions is not implied. All voltage values are referred to V_{SS} pin voltage.

Table 5: Recommended Operating Conditions

Symbol	Parameter	Value	Unit
V _{DD}	Supply Voltage	3 to 20	V
V _I	Input Voltage	0 to V _{DD}	V
T _{op}	Operating Temperature	-55 to 125	°C

Table 6: DC Specifications

Symbol	Parameter	Test Condition				Value						Unit	
		V _I (V)	V _O (V)	I _o (μ A)	V _{DD} = V _{CC} (V)	T _A = 25°C			-40 to 85°C		-55 to 125°C		
						Min.	Typ.	Max.	Min.	Max.	Min.		Max.
I _L	Quiescent Current	0/5			5		0.02	1		30		30	μ A
		0/10			10		0.02	2		60		60	
		0/15			15		0.02	4		120		120	
		0/20			20		0.04	20		600		600	
V _{OH}	High Level Output Voltage	0/5		<1	5	4.95			4.95		4.95		V
		0/10		<1	10	9.95			9.95		9.95		
		0/15		<1	15	14.95			14.95		14.95		
V _{OL}	Low Level Output Voltage	5/0		<1	5		0.05			0.05		0.05	V
		10/0		<1	10		0.05			0.05		0.05	
		15/0		<1	15		0.05			0.05		0.05	
V _{IH}	High Level Input Voltage		0.5/4.5	<1	5	3.5			3.5		3.5		V
			1/9	<1	10	7			7		7		
			1.5/13.5	<1	15	11			11		11		
V _{IL}	Low Level Input Voltage		4.5/0.5	<1	5			1.5		1.5		1.5	V
			9/1	<1	10			3		3		3	
			13.5/1.5	<1	15			4		4		4	
I _{OH}	Output Drive Current	0/5	2.5	<1	5	-0.8	-1.6		-0.65		-0.65		mA
		0/5	4.6	<1	5	-0.2	-0.4		-0.18		-0.18		
		0/10	9.5	<1	10	-0.45	-0.9		-0.38		-0.38		
		0/15	13.5	<1	15	-1.5	-3		-1.25		-1.25		
I _{OL}	Output Sink Current	0/5	0.4	<1	5	3	4		2.4		2.4		mA
		0/10	0.5	<1	10	8	10		6.4		6.4		
		0/15	1.5	<1	15	24	36		19		19		
I _I	Input Leakage Current	0/18	Any Input		18		$\pm 10^{-5}$	± 0.1		± 1		± 1	μ A
C _I	Input Capacitance		Any Input				5	7.5					pF

The Noise Margin for both "1" and "0" level is: 1V min. with V_{DD}=5V, 2V min. with V_{DD}=10V, 2.5V min. with V_{DD}=15V

Table 7: Dynamic Electrical Characteristics ($T_{amb} = 25^{\circ}C$, $C_L = 50pF$, $R_L = 200K\Omega$, $t_r = t_f = 20 ns$)

Symbol	Parameter	Test Condition			Value (*)			Unit
		V _{DD} (V)	V _I (V)	V _{CC} (V)	Min.	Typ.	Max.	
t _{TLH}	Output Transition Time	5	5	5		150	350	ns
		10	10	10		75	15	
		15	15	15		55	110	
t _{THL}	Output Transition Time	5	5	5		35	70	ns
		10	10	10		20	40	
		15	15	15		15	30	
t _{PLH}	Propagation Delay Time	5	5	5		100	200	ns
		10	10	10		50	100	
		10	10	5		50	100	
		15	15	15		35	70	
		15	15	5		35	70	
t _{PHL}	Propagation Delay Time	5	5	5		65	130	ns
		10	10	10		35	70	
		10	10	5		30	70	
		15	15	15		25	50	
		15	15	5		20	40	

(*) Typical temperature coefficient for all V_{DD} value is 0.3%/°C.

Figure 3: Test Circuit

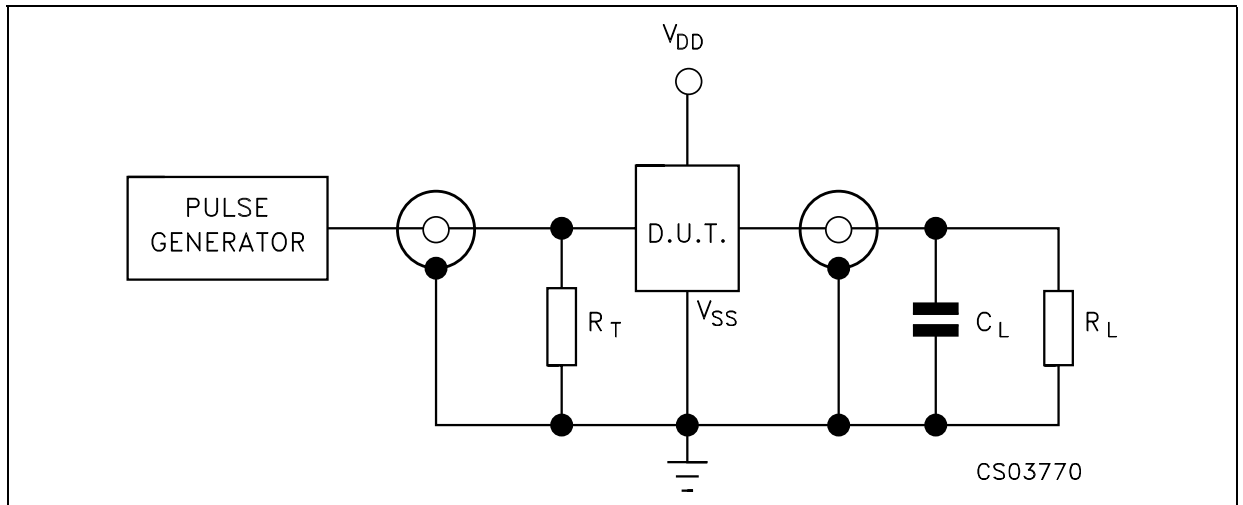

C_L = 50pF or equivalent (includes jig and probe capacitance)
 R_L = 200KΩ
 R_T = Z_{OUT} of pulse generator (typically 50Ω)

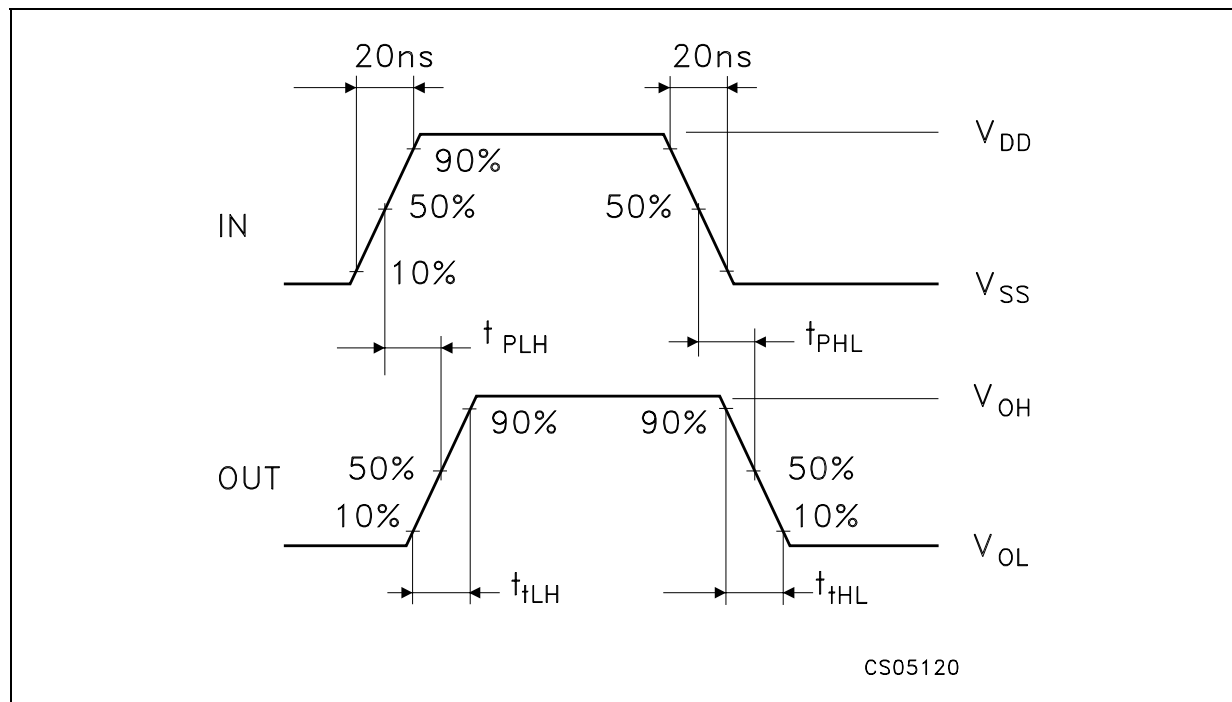
Figure 4: Waveform - Propagation Delay Times ($f=1\text{MHz}$; 50% duty cycle)

Plastic DIP-16 (0.25) MECHANICAL DATA

DIM.	mm.			inch		
	MIN.	TYP	MAX.	MIN.	TYP.	MAX.
a1	0.51			0.020		
B	0.77		1.65	0.030		0.065
b		0.5			0.020	
b1		0.25			0.010	
D			20			0.787
E		8.5			0.335	
e		2.54			0.100	
e3		17.78			0.700	
F			7.1			0.280
l			5.1			0.201
L		3.3			0.130	
Z			1.27			0.050

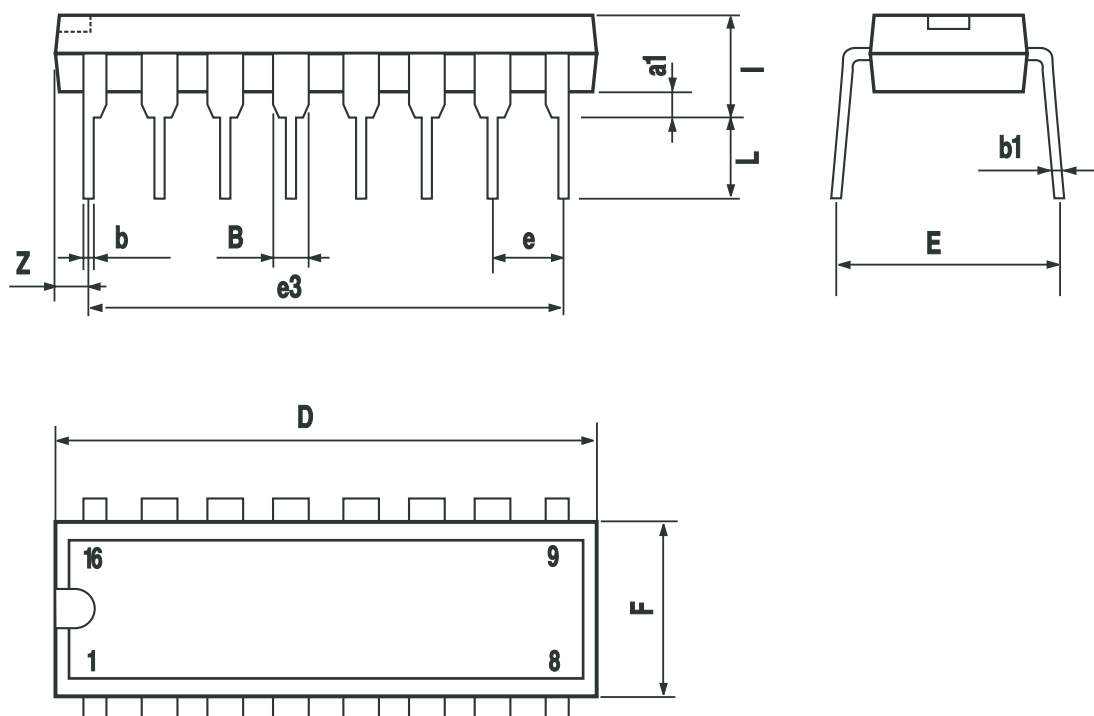

P001C

SO-16 MECHANICAL DATA

DIM.	mm.			inch		
	MIN.	TYP.	MAX.	MIN.	TYP.	MAX.
A			1.75			0.068
a1	0.1		0.25	0.004		0.010
a2			1.64			0.063
b	0.35		0.46	0.013		0.018
b1	0.19		0.25	0.007		0.010
C		0.5			0.019	
c1	45° (typ.)					
D	9.8		10	0.385		0.393
E	5.8		6.2	0.228		0.244
e		1.27			0.050	
e3		8.89			0.350	
F	3.8		4.0	0.149		0.157
G	4.6		5.3	0.181		0.208
L	0.5		1.27	0.019		0.050
M			0.62			0.024
S	8° (max.)					

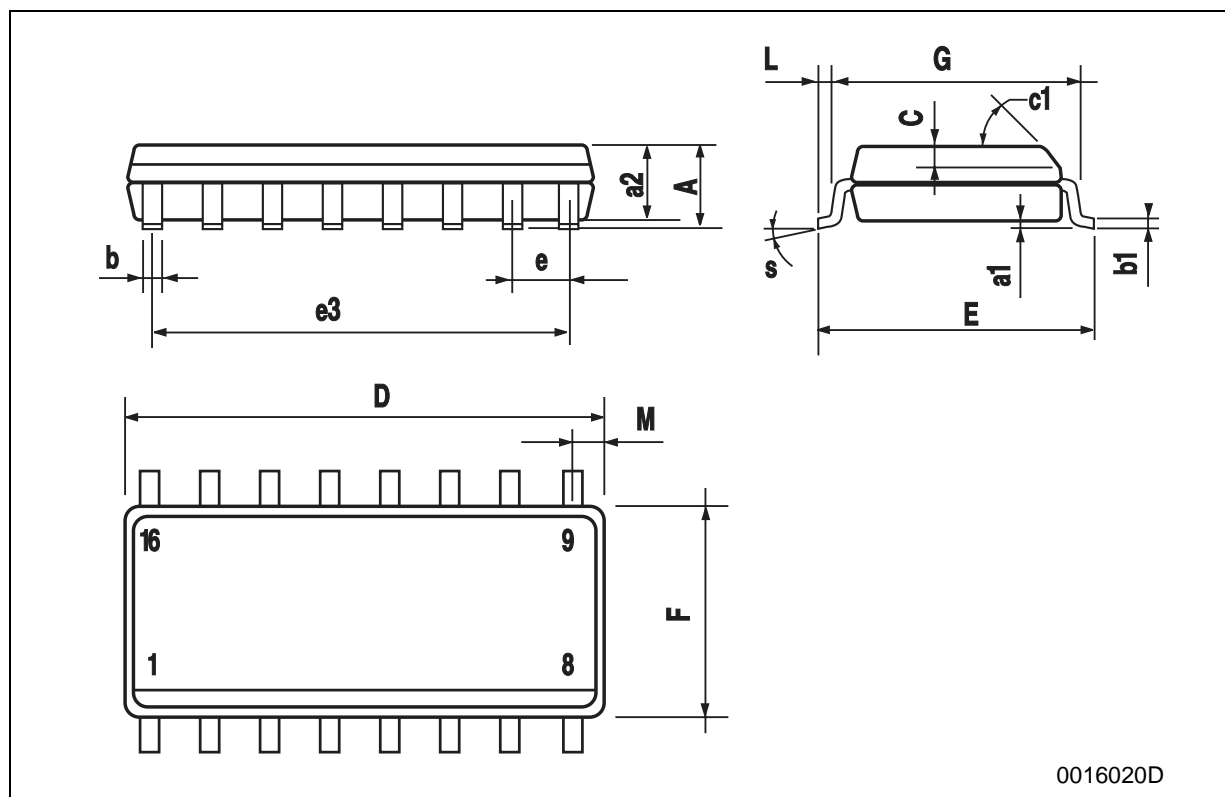

0016020D

Tape & Reel SO-16 MECHANICAL DATA

DIM.	mm.			inch		
	MIN.	TYP	MAX.	MIN.	TYP.	MAX.
A			330			12.992
C	12.8		13.2	0.504		0.519
D	20.2			0.795		
N	60			2.362		
T			22.4			0.882
Ao	6.45		6.65	0.254		0.262
Bo	10.3		10.5	0.406		0.414
Ko	2.1		2.3	0.082		0.090
Po	3.9		4.1	0.153		0.161
P	7.9		8.1	0.311		0.319

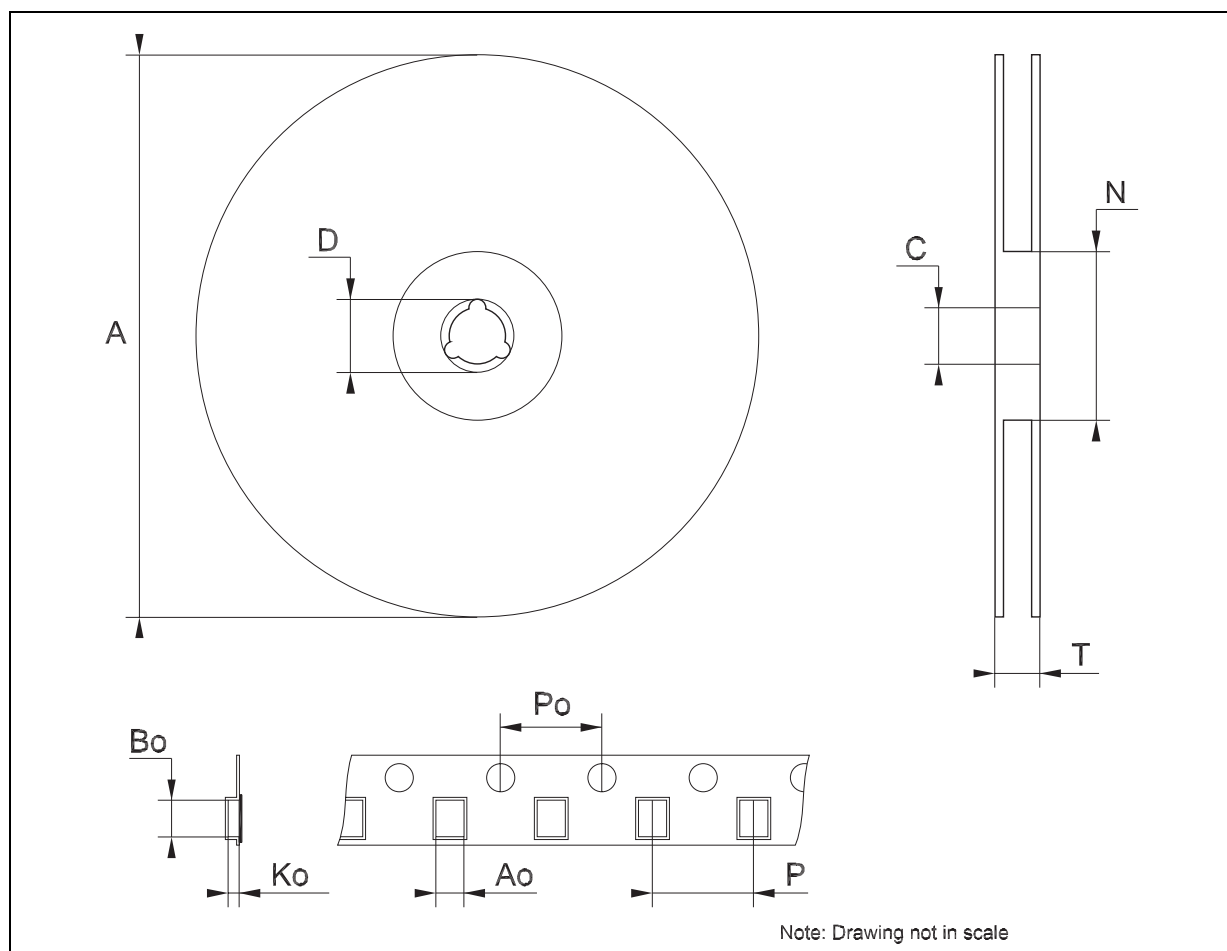

Table 8: Revision History

Date	Revision	Description of Changes
16-Mar-2005	3	Add V_{CC} on Table 6.

Information furnished is believed to be accurate and reliable. However, STMicroelectronics assumes no responsibility for the consequences of use of such information nor for any infringement of patents or other rights of third parties which may result from its use. No license is granted by implication or otherwise under any patent or patent rights of STMicroelectronics. Specifications mentioned in this publication are subject to change without notice. This publication supersedes and replaces all information previously supplied. STMicroelectronics products are not authorized for use as critical components in life support devices or systems without express written approval of STMicroelectronics.

The ST logo is a registered trademark of STMicroelectronics

All other names are the property of their respective owners

© 2005 STMicroelectronics - All Rights Reserved

STMicroelectronics group of companies

Australia - Belgium - Brazil - Canada - China - Czech Republic - Finland - France - Germany - Hong Kong - India - Israel - Italy - Japan - Malaysia - Malta - Morocco - Singapore - Spain - Sweden - Switzerland - United Kingdom - United States of America

www.st.com