

## 阅读申明

- 1.本站收集的数据手册和产品资料都来自互联网，版权归原作者所有。如读者和版权方有任何异议请及时告之，我们将妥善解决。
- 2.本站提供的中文数据手册是英文数据手册的中文翻译，其目的是协助用户阅读，该译文无法自动跟随原稿更新，同时也可能存在翻译上的不当。建议读者以英文原稿为参考以便获得更精准的信息。
- 3.本站提供的产品资料，来自厂商的技术支持或者使用者的心得体会等，其内容可能存在描述上的差异，建议读者做出适当判断。
- 4.如需与我们联系，请发邮件到marketing@iczoom.com，主题请标有“数据手册”字样。

## Read Statement

1. The datasheets and other product information on the site are all from network reference or other public materials, and the copyright belongs to the original author and original published source. If readers and copyright owners have any objections, please contact us and we will deal with it in a timely manner.
2. The Chinese datasheets provided on the website is a Chinese translation of the English datasheets. Its purpose is for reader's learning exchange only and do not involve commercial purposes. The translation cannot be automatically updated with the original manuscript, and there may also be improper translations. Readers are advised to use the English manuscript as a reference for more accurate information.
3. All product information provided on the website refer to solutions from manufacturers' technical support or users the contents may have differences in description, and readers are advised to take the original article as the standard.
4. If you have any questions, please contact us at marketing@iczoom.com and mark the subject with "Datasheets" .

**Product Features:**

**Common Features:**

- PI74FCT16374T, PI74FCT162374T, and PI74FCT162H374T are high-speed, low power devices with high current drive.
- $V_{CC} = 5V \pm 10\%$
- Hysteresis on all inputs
- Packages available:
  - 48-pin 240 mil wide plastic TSSOP (A)
  - 48-pin 300 mil wide plastic SSOP (V)

**PI74FCT16374T Features:**

- High output drive:  $I_{OH} = -32\text{ mA}$ ;  $I_{OL} = 64\text{ mA}$
- Power off disable outputs permit "live insertion"
- Typical  $V_{OLP}$  (Output Ground Bounce)  $< 1.0V$  at  $V_{CC} = 5V, T_A = 25^\circ C$

**PI74FCT162374T Features:**

- Balanced output drivers:  $\pm 24\text{ mA}$
- Reduced system switching noise
- Typical  $V_{OLP}$  (Output Ground Bounce)  $< 0.6V$  at  $V_{CC} = 5V, T_A = 25^\circ C$

**PI74FCT162H374T Features:**

- Bus Hold retains last active bus state during 3-state
- Eliminates the need for external pull-up resistors

**Product Description:**

Pericom Semiconductor's PI74FCT series of logic circuits are produced in the Company's advanced 0.6 micron CMOS technology, achieving industry leading speed grades.

The PI74FCT16374T, PI74FCT162374T, and PI74FCT162H374T are 16-bit octal registers designed with 16 D-type flip-flops with a buffered common clock and 3-state outputs. The Output Enable ( $\overline{xOE}$ ) and clock ( $\overline{xCLK}$ ) controls are organized to operate as two 8-bit registers or one 16-bit register. When OE is HIGH, the outputs are in the high impedance state. Input data meeting the setup and hold time requirements of the D inputs is transferred to the O outputs on the LOW-to-HIGH transition of the clock input.

The PI74FCT16374T output buffers are designed with a Power-Off Disable allowing "live insertion" of boards when used as backplane drivers.

The PI74FCT162374T has  $\pm 24\text{ mA}$  balanced output drivers. It is designed with current limiting resistors at its outputs to control the output edge rate resulting in lower ground bounce and undershoot. This eliminates the need for external terminating resistors for most interface applications.

The PI74FCT162H374T has "Bus Hold" which retains the input's last state whenever the input goes to high-impedance preventing "floating" inputs and eliminating the need for pull-up/down resistors.

**Logic Block Diagram**

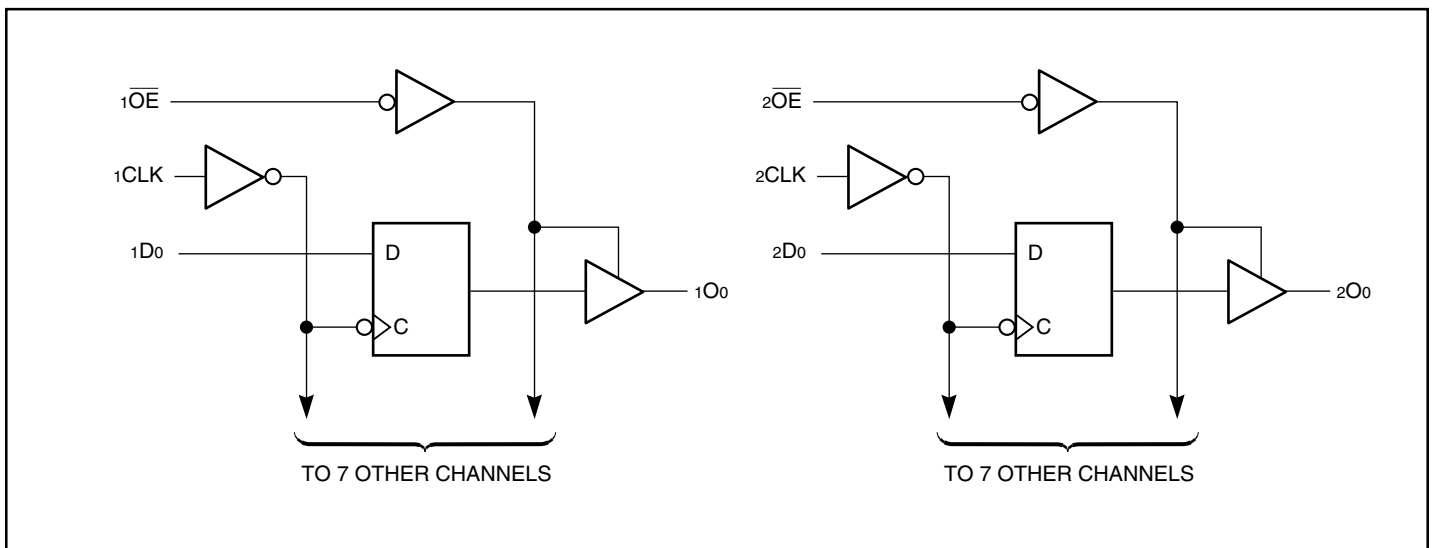

### Product Pin Description

Pin Name	Description
$\overline{xOE}$	3-State Output Enable Inputs (Active LOW)
xCLK	Clock Inputs
$xDx$	Inputs <sup>(1)</sup>
$xOx$	3-State Outputs
GND	Ground
Vcc	Power

**Note:** 1. For the PI74FCT162H374T, these pins have “Bus Hold.” All other pins are standard, outputs, or I/Os.

### Truth Table<sup>(1)</sup>

Function	Inputs			Outputs
	$xDx$	$xCLK$	$\overline{xOE}$	$xOx$
High-Z	X	L	H	Z
	X	H	H	Z
Load Register	L	↑	L	L
	H	↑	L	H
	L	↑	H	Z
	H	↑	H	Z

**Note:**

- H = High Voltage Level  
L = Low Voltage Level  
X = Don't Care  
Z = High Impedance  
↑ = LOW-to-HIGH transition

### Product Pin Configuration

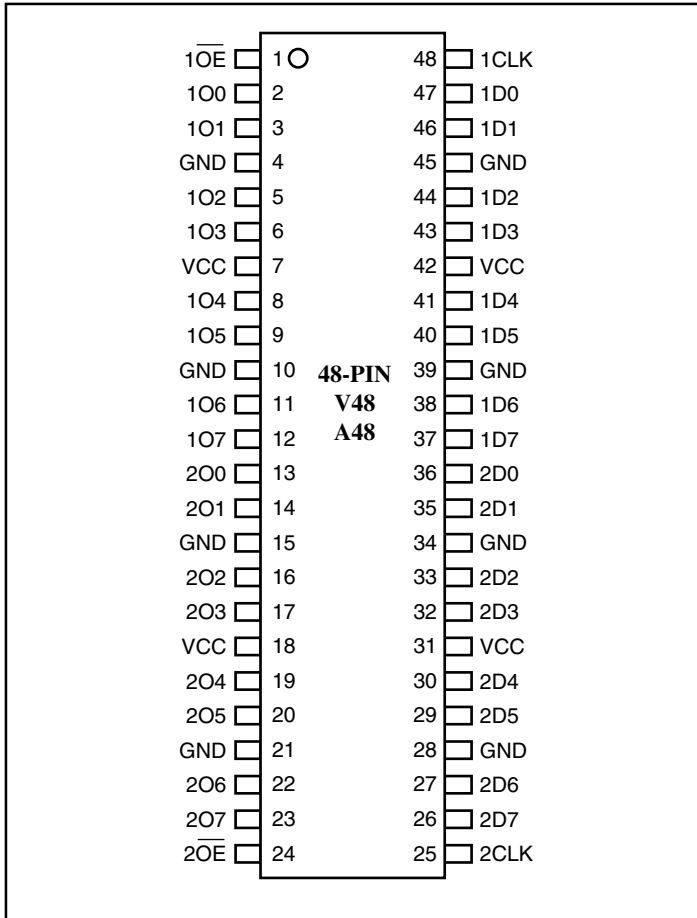

### Maximum Ratings

(Above which the useful life may be impaired. For user guidelines, not tested.)

Storage Temperature .....	-65°C to +150°C
Ambient Temperature with Power Applied .....	-40°C to +85°C
Supply Voltage to Ground Potential (Inputs & Vcc Only) .....	-0.5V to +7.0V
Supply Voltage to Ground Potential (Outputs & D/O Only) .....	-0.5V to +7.0V
DC Input Voltage .....	-0.5V to +7.0V
DC Output Current .....	120mA
Power Dissipation .....	1.0W

**Note:**

Stresses greater than those listed under MAXIMUM RATINGS may cause permanent damage to the device. This is a stress rating only and functional operation of the device at these or any other conditions above those indicated in the operational sections of this specification is not implied. Exposure to absolute maximum rating conditions for extended periods may affect reliability.

### DC Electrical Characteristics (Over the Operating Range, TA = -40°C to +85°C, VCC = 5.0V ± 10%)

Parameters	Description	Test Conditions <sup>(1)</sup>		Min.	Typ <sup>(2)</sup>	Max.	Units
V <sub>IH</sub>	Input HIGH Voltage	Guaranteed Logic HIGH Level		2.0			V
V <sub>IL</sub>	Input LOW Voltage	Guaranteed Logic LOW Level				0.8	V
I <sub>IH</sub>	Input HIGH Current	Standard Input, V <sub>CC</sub> = Max.	V <sub>IN</sub> = V <sub>CC</sub>			1	μA
I <sub>IH</sub>	Input HIGH Current	Standard I/O, V <sub>CC</sub> = Max.	V <sub>IN</sub> = V <sub>CC</sub>			1	μA
I <sub>IH</sub>	Input HIGH Current	Bus Hold Input <sup>(4)</sup> , V <sub>CC</sub> = Max.	V <sub>IN</sub> = V <sub>CC</sub>			±100	μA
I <sub>IH</sub>	Input HIGH Current	Bus Hold I/O <sup>(4)</sup> , V <sub>CC</sub> = Max.	V <sub>IN</sub> = V <sub>CC</sub>			±100	μA
I <sub>IL</sub>	Input LOW Current	Standard Input, V <sub>CC</sub> = Min.	V <sub>IN</sub> = GND			-1	μA
I <sub>IL</sub>	Input LOW Current	Standard I/O, V <sub>CC</sub> = Min.	V <sub>IN</sub> = GND			-1	μA
I <sub>IL</sub>	Input LOW Current	Bus Hold Input <sup>(4)</sup> , V <sub>CC</sub> = Min.	V <sub>IN</sub> = GND			±100	μA
I <sub>IL</sub>	Input LOW Current	Bus Hold I/O <sup>(4)</sup> , V <sub>CC</sub> = Min.	V <sub>IN</sub> = GND			±100	μA
I <sub>BHH</sub>	Bus Hold Sustain Current	Bus Hold Input <sup>(4)</sup> , V <sub>CC</sub> = Min.	V <sub>IN</sub> = 2.0V	-50			μA
I <sub>BHL</sub>			V <sub>IN</sub> = 0.8V	+50			
I <sub>OZH</sub> <sup>(5)</sup>	High Impedance	V <sub>CC</sub> = Max.	V <sub>OUT</sub> = 2.7V			1	μA
I <sub>OZL</sub> <sup>(5)</sup>	Output Current	V <sub>CC</sub> = Max.	V <sub>OUT</sub> = 0.5V			-1	μA
V <sub>IK</sub>	Clamp Diode Voltage	V <sub>CC</sub> = Min., I <sub>IN</sub> = -18 mA			-0.7	-1.2	V
I <sub>OS</sub>	Short Circuit Current	V <sub>CC</sub> = Max. <sup>(3)</sup> , V <sub>OUT</sub> = GND		-80	-140	-200	mA
I <sub>O</sub>	Output Drive Current	V <sub>CC</sub> = Max. <sup>(3)</sup> , V <sub>OUT</sub> = 2.5V		-50		-180	mA
V <sub>H</sub>	Input Hysteresis				100		mV

**Notes:**

1. For Max. or Min. conditions, use appropriate value specified under Electrical Characteristics for the applicable device type.
2. Typical values are at V<sub>CC</sub> = 5.0V, +25°C ambient and maximum loading.
3. Not more than one output should be shorted at one time. Duration of the test should not exceed one second.
4. Pins with Bus Hold are identified in the pin description.
5. This specification does not apply to bi-directional functionalities with Bus Hold.

**PI74FCT16374T Output Drive Characteristics** (Over the Operating Range)

Parameters	Description	Test Conditions <sup>(1)</sup>		Min.	Typ <sup>(2)</sup>	Max.	Units
VOH	Output HIGH Voltage	VCC = Min., VIN = VIH or VIL	IOH = -3.0 mA	2.5	3.5		V
			IOH = -15.0 mA	2.4	3.5		
			IOH = -32.0 mA	2.0	3.0		
VOL	Output LOW Voltage	VCC = Min., VIN = VIH or VIL	IOL = 64 mA		0.2	0.55	V
IOFF	Power Down Disable	VCC = 0V, VIN or VOUT $\leq$ 5V		—	—	±100	µA

**PI74FCT162374T/162H374T Output Drive Characteristics** (Over the Operating Range)

Parameters	Description	Test Conditions <sup>(1)</sup>		Min.	Typ <sup>(2)</sup>	Max.	Units
VOH	Output HIGH Voltage	VCC = Min., VIN = VIH or VIL	IOH = -24.0 mA	2.4	3.3		V
VOL	Output LOW Voltage	VCC = Min., VIN = VIH or VIL	IOL = 24 mA		0.3	0.55	V
IODL	Output LOW Current	VCC = 5V, VIN = VIH OR VIL, VOUT = 1.5V <sup>(3)</sup>		60	115	150	mA
IODH	Output HIGH Current	VCC = 5V, VIN = VIH OR VIL, VOUT = 1.5V <sup>(3)</sup>		-60	-115	-150	mA

**Capacitance** (TA = 25°C, f = 1 MHz)

Parameters <sup>(4)</sup>	Description	Test Conditions	Typ	Max.	Units
CIN	Input Capacitance	VIN = 0V	4.5	6	pF
COUT	Output Capacitance	VOUT = 0V	5.5	8	pF

**Notes:**

1. For Max. or Min. conditions, use appropriate value specified under Electrical Characteristics for the applicable device type.
2. Typical values are at VCC = 5.0V, +25°C ambient and maximum loading.
3. Not more than one output should be shorted at one time. Duration of the test should not exceed one second.
4. This parameter is determined by device characterization but is not production tested.

**Power Supply Characteristics**

Parameters	Description	Test Conditions <sup>(1)</sup>		Min.	Typ <sup>(2)</sup>	Max.	Units
I <sub>CC</sub>	Quiescent Power Supply Current	V <sub>CC</sub> = Max.	V <sub>IN</sub> = GND or V <sub>CC</sub>		0.1	500	μA
ΔI <sub>CC</sub>	Supply Current per Input @ TTL HIGH	V <sub>CC</sub> = Max.	V <sub>IN</sub> = 3.4V <sup>(3)</sup>		0.5	1.5	mA
I <sub>CCD</sub>	Supply Current per Input per MHz <sup>(4)</sup>	V <sub>CC</sub> = Max., Outputs Open x $\overline{OE}$ = GND One Bit Toggling 50% Duty Cycle	V <sub>IN</sub> = V <sub>CC</sub> V <sub>IN</sub> = GND		60	100	μA/ MHz
I <sub>C</sub>	Total Power Supply Current <sup>(6)</sup>	V <sub>CC</sub> = Max., Outputs Open f <sub>CP</sub> = 10 MHz 50% Duty Cycle x $\overline{OE}$ = GND f <sub>I</sub> = 5 MHz 50% Duty Cycle One Bit Toggling	V <sub>IN</sub> = V <sub>CC</sub> V <sub>IN</sub> = GND		0.6	1.5 <sup>(5)</sup>	mA
			V <sub>IN</sub> = 3.4V V <sub>IN</sub> = GND		1.1	3.0 <sup>(5)</sup>	
		V <sub>CC</sub> = Max., Outputs Open f <sub>CP</sub> = 10 MHz 50% Duty Cycle x $\overline{OE}$ = GND 16 Bits Toggling f <sub>I</sub> = 2.5 MHz 50% Duty Cycle	V <sub>IN</sub> = V <sub>CC</sub> V <sub>IN</sub> = GND		3.0	5.5 <sup>(5)</sup>	
			V <sub>IN</sub> = 3.4V V <sub>IN</sub> = GND		7.5	19.0 <sup>(5)</sup>	

**Notes:**

- For Max. or Min. conditions, use appropriate value specified under Electrical Characteristics for the applicable device.
- Typical values are at V<sub>CC</sub> = 5.0V, +25°C ambient.
- Per TTL driven input (V<sub>IN</sub> = 3.4V); all other inputs at V<sub>CC</sub> or GND.
- This parameter is not directly testable, but is derived for use in Total Power Supply Calculations.
- Values for these conditions are examples of the I<sub>CC</sub> formula. These limits are guaranteed but not tested.
- I<sub>C</sub> = I<sub>QUIESCENT</sub> + I<sub>INPUTS</sub> + I<sub>DYNAMIC</sub>  
 $I_C = I_{CC} + \Delta I_{CC} D_H N_T + I_{CCD} (f_{CP}/2 + f_I N_I)$   
 I<sub>CC</sub> = Quiescent Current  
 ΔI<sub>CC</sub> = Power Supply Current for a TTL High Input (V<sub>IN</sub> = 3.4V)  
 D<sub>H</sub> = Duty Cycle for TTL Inputs High  
 N<sub>T</sub> = Number of TTL Inputs at D<sub>H</sub>  
 I<sub>CCD</sub> = Dynamic Current Caused by an Input Transition Pair (HLH or LHL)  
 f<sub>CP</sub> = Clock Frequency for Register Devices (Zero for Non-Register Devices)  
 f<sub>I</sub> = Input Frequency  
 N<sub>I</sub> = Number of Inputs at f<sub>I</sub>  
 All currents are in milliamps and all frequencies are in megahertz.

**PI74FCT16374T Switching Characteristics over Operating Range**

Parameters	Description	Conditions <sup>(1)</sup>	16374T		16374AT		16374CT		16374DT		16374ET		Unit
			Com.		Com.		Com.		Com.		Com.		
			Min	Max	Min	Max	Min	Max	Min	Max	Min	Max	
tPLH tPHL	Propagation Delay xCLKx to xOx	CL = 50 pF RL = 500Ω	20	100	20	65	20	52	20	42	15	37	ns
tpZH tpZL	Output Enable Time xOE to xOx		1.5	12.5	1.5	6.5	1.5	5.5	1.5	4.8	1.5	4.4	ns
tpHZ tPLZ	Output Disable Time <sup>(3)</sup> xOE to xOx		1.5	80	1.5	55	1.5	50	1.5	40	1.5	40	ns
tsu	Setup Time HIGH or LOW, xDx to xCLK		2.0	—	2.0	—	2.0	—	2.0	—	1.5	—	ns
th	Hold Time HIGH or LOW, xDx to xCLK		1.5	—	1.5	—	1.5	—	1.0	—	0.0	—	ns
tw	xCLK Pulse Width HIGH or LOW <sup>(3)</sup>		7.0	—	5.0	—	5.0	—	3.0	—	3.0	—	ns
tsk(o)	Output Skew <sup>(4)</sup>		—	0.5	—	0.5	—	0.5	—	0.5	—	0.5	ns

**PI74FCT162374T Switching Characteristics over Operating Range**

Parameters	Description	Conditions <sup>(1)</sup>	162374T		162374AT		162374CT		162374DT		162374ET		Unit
			Com.		Com.		Com.		Com.		Com.		
			Min	Max	Min	Max	Min	Max	Min	Max	Min	Max	
tPLH tPHL	Propagation Delay xCLKx to xOx	CL = 50 pF RL = 500Ω	20	100	20	65	20	52	20	42	15	37	ns
tpZH tpZL	Output Enable Time xOE to xOx		1.5	12.5	1.5	6.5	1.5	5.5	1.5	4.8	1.5	4.4	ns
tpHZ tPLZ	Output Disable Time <sup>(3)</sup> xOE to xOx		1.5	80	1.5	55	1.5	50	1.5	40	1.5	40	ns
tsu	Setup Time HIGH or LOW, xDx to xCLK		2.0	—	2.0	—	2.0	—	2.0	—	1.5	—	ns
th	Hold Time HIGH or LOW, xDx to xCLK		1.5	—	1.5	—	1.5	—	1.0	—	0.0	—	ns
tw	xCLK Pulse Width HIGH or LOW <sup>(3)</sup>		7.0	—	5.0	—	5.0	—	3.0	—	3.0	—	ns
tsk(o)	Output Skew <sup>(4)</sup>		—	0.5	—	0.5	—	0.5	—	0.5	—	0.5	ns

**Notes:**

1. See test circuit and wave forms.
2. Minimum limits are guaranteed but not tested on Propagation Delays.
3. This parameter is guaranteed but not production tested.
4. Skew between any two outputs, of the same package, switching in the same direction. This parameter is guaranteed by design.

**PI74FCT162H374T Switching Characteristics over Operating Range**

Parameters	Description	Conditions <sup>(1)</sup>	162H374T		162H374AT		162H374CT		162H374DT		162H374ET		Unit
			Com.		Com.		Com.		Com.		Com.		
			Min	Max	Min	Max	Min	Max	Min	Max	Min	Max	
tPLH tPHL	Propagation Delay xCLKx to xOx	CL = 50 pF RL = 500Ω	2.0	10.0	2.0	6.5	2.0	5.2	2.0	4.2	1.5	3.7	ns
tpZH tpZL	Output Enable Time xOE to xOx		1.5	12.5	1.5	6.5	1.5	5.5	1.5	4.8	1.5	4.4	ns
tpHZ tPLZ	Output Disable Time <sup>(3)</sup> xOE to xOx		1.5	8.0	1.5	5.5	1.5	5.0	1.5	4.0	1.5	4.0	ns
tsU	Setup Time HIGH or LOW, xDx to xCLK		2.0	—	2.0	—	2.0	—	2.0	—	1.5	—	ns
tH	Hold Time HIGH or LOW, xDx to xCLK		1.5	—	1.5	—	1.5	—	1.0	—	0.0	—	ns
tw	xCLK Pulse Width HIGH or LOW <sup>(3)</sup>		7.0	—	5.0	—	5.0	—	3.0	—	3.0	—	ns
tsk(o)	Output Skew <sup>(4)</sup>		—	0.5	—	0.5	—	0.5	—	0.5	—	0.5	ns

**Notes:**

1. See test circuit and wave forms.
2. Minimum limits are guaranteed but not tested on Propagation Delays.
3. This parameter is guaranteed but not production tested.
4. Skew between any two outputs, of the same package, switching in the same direction. This parameter is guaranteed by design.