

## 阅读申明

- 1.本站收集的数据手册和产品资料都来自互联网，版权归原作者所有。如读者和版权方有任何异议请及时告之，我们将妥善解决。
- 2.本站提供的中文数据手册是英文数据手册的中文翻译，其目的是协助用户阅读，该译文无法自动跟随原稿更新，同时也可能存在翻译上的不当。建议读者以英文原稿为参考以便获得更精准的信息。
- 3.本站提供的产品资料，来自厂商的技术支持或者使用者的心得体会等，其内容可能存在描述上的差异，建议读者做出适当判断。
- 4.如需与我们联系，请发邮件到marketing@iczoom.com，主题请标有“数据手册”字样。

## Read Statement

1. The datasheets and other product information on the site are all from network reference or other public materials, and the copyright belongs to the original author and original published source. If readers and copyright owners have any objections, please contact us and we will deal with it in a timely manner.
2. The Chinese datasheets provided on the website is a Chinese translation of the English datasheets. Its purpose is for reader's learning exchange only and do not involve commercial purposes. The translation cannot be automatically updated with the original manuscript, and there may also be improper translations. Readers are advised to use the English manuscript as a reference for more accurate information.
3. All product information provided on the website refer to solutions from manufacturers' technical support or users the contents may have differences in description, and readers are advised to take the original article as the standard.
4. If you have any questions, please contact us at marketing@iczoom.com and mark the subject with "Datasheets" .

# SN54AS825A, SN74AS825A 8-BIT BUS-INTERFACE FLIP-FLOPS WITH 3-STATE OUTPUTS

SDAS020B – JUNE 1984 – REVISED AUGUST 1995

- Functionally Equivalent to AMD's AM29825
- Improved  $I_{OH}$  Specifications
- Multiple Output Enables Allow Multiuser Control of the Interface
- Outputs Have Undershoot-Protection Circuitry
- Power-Up High-Impedance State
- Buffered Control Inputs Reduce dc Loading Effects
- Package Options Include Plastic Small-Outline (DW) Packages, Ceramic Chip Carriers (FK), and Standard Plastic (NT) and Ceramic (JT) 300-mil DIPs

## description

These 8-bit flip-flops feature 3-state outputs designed specifically for driving highly capacitive or relatively low-impedance loads. These devices are particularly suitable for implementing multiuser registers, I/O ports, bidirectional bus drivers, and working registers.

With the clock-enable ( $\overline{CLKEN}$ ) input low, the eight D-type edge-triggered flip-flops enter data on the low-to-high transitions of the clock (CLK) input. Taking  $\overline{CLKEN}$  high disables the clock buffer, latching the outputs. These devices have noninverting data (D) inputs. Taking the clear ( $\overline{CLR}$ ) input low causes the eight Q outputs to go low independently of the clock.

Multiuser buffered output-enable ( $\overline{OE1}$ ,  $\overline{OE2}$ , and  $\overline{OE3}$ ) inputs can be used to place the eight outputs in either a normal logic state (high or low logic level) or a high-impedance state. In the high-impedance state, the outputs neither load nor drive the bus lines significantly. The high-impedance state and increased drive provide the capability to drive bus lines without interface or pullup components.

The output enables do not affect the internal operation of the flip-flops. Old data can be retained or new data can be entered while the outputs are in the high-impedance state.

The SN54AS825A is characterized for operation over the full military temperature range of  $-55^{\circ}\text{C}$  to  $125^{\circ}\text{C}$ . The SN74AS825A is characterized for operation from  $0^{\circ}\text{C}$  to  $70^{\circ}\text{C}$ .

SN54AS825A . . . JT PACKAGE  
SN74AS825A . . . DW OR NT PACKAGE  
(TOP VIEW)

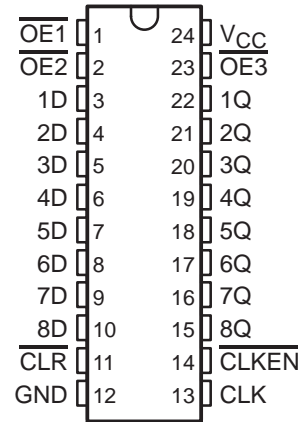

SN54AS825A . . . FK PACKAGE  
(TOP VIEW)

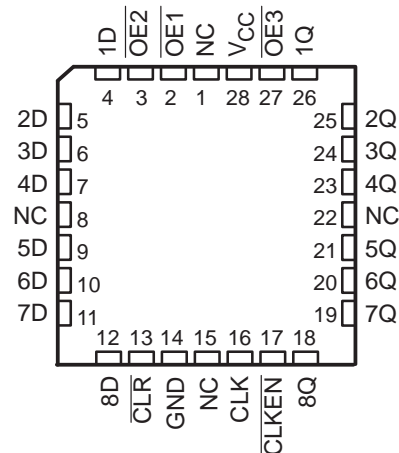

NC – No internal connection

# SN54AS825A, SN74AS825A 8-BIT BUS-INTERFACE FLIP-FLOPS WITH 3-STATE OUTPUTS

SDAS020B – JUNE 1984 – REVISED AUGUST 1995

FUNCTION TABLE  
(each flip-flop)

| INPUTS                 |                  |                    |     |   | OUTPUT |
|------------------------|------------------|--------------------|-----|---|--------|
| $\overline{OE}\dagger$ | $\overline{CLR}$ | $\overline{CLKEN}$ | CLK | D | Q      |
| L                      | L                | X                  | X   | X | L      |
| L                      | H                | L                  | ↑   | H | H      |
| L                      | H                | L                  | ↑   | L | L      |
| L                      | H                | H                  | X   | X | $Q_0$  |
| H                      | X                | X                  | X   | X | Z      |

$\dagger \overline{OE} = H$  if any of  $\overline{OE1}$ ,  $\overline{OE2}$ , or  $\overline{OE3}$  are high.  
 $\overline{OE} = L$  if all of  $\overline{OE1}$ ,  $\overline{OE2}$ , or  $\overline{OE3}$  are low.

## logic symbol‡

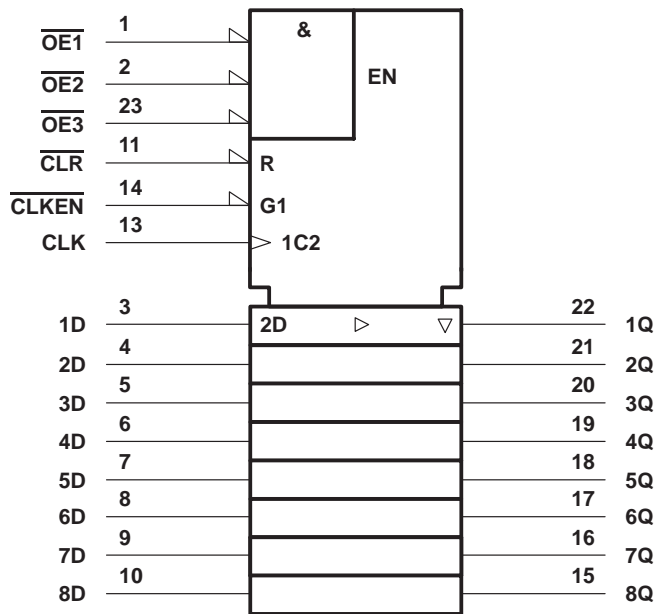

‡ This symbol is in accordance with ANSI/IEEE Std 91-1984 and IEC Publication 617-12.  
 Pin numbers shown are for the DW, JT, and NT packages.

**SN54AS825A, SN74AS825A**  
**8-BIT BUS-INTERFACE FLIP-FLOPS**  
**WITH 3-STATE OUTPUTS**

SDAS020B – JUNE 1984 – REVISED AUGUST 1995

**logic diagram (positive logic)**

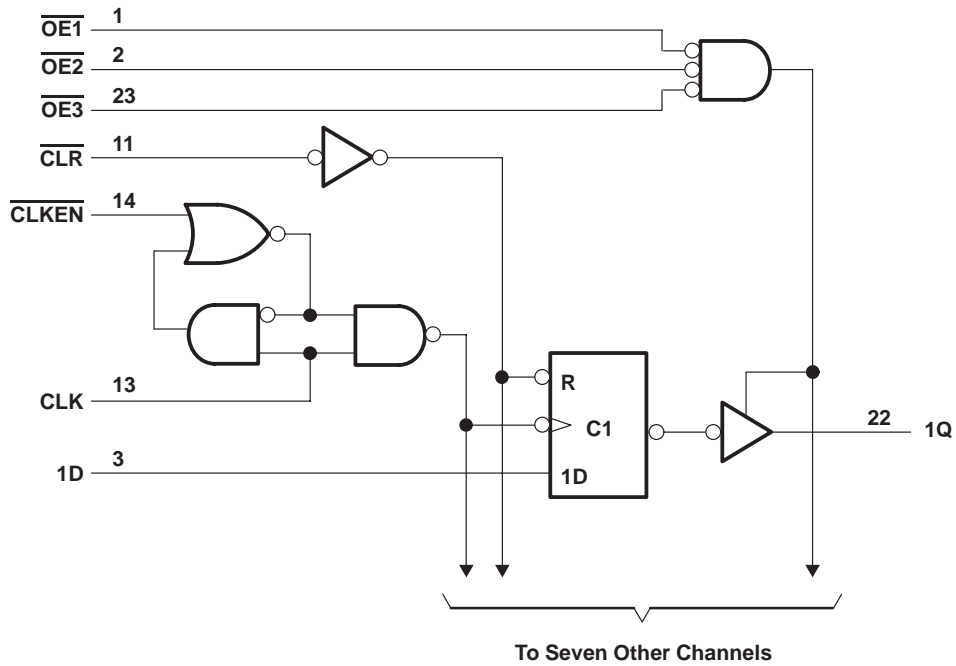

Pin numbers shown are for the DW, JT, and NT packages.

**absolute maximum ratings over operating free-air temperature range (unless otherwise noted)†**

|  |                |
|--|----------------|
| Supply voltage, $V_{CC}$                                 | 7 V            |
| Input voltage, $V_I$                                     | 7 V            |
| Voltage applied to a disabled 3-state output             | 5.5 V          |
| Operating free-air temperature range, $T_A$ : SN54AS825A | -55°C to 125°C |
| SN74AS825A   | 0°C to 70°C    |
| Storage temperature range                                | -65°C to 150°C |

† Stresses beyond those listed under "absolute maximum ratings" may cause permanent damage to the device. These are stress ratings only, and functional operation of the device at these or any other conditions beyond those indicated under "recommended operating conditions" is not implied. Exposure to absolute-maximum-rated conditions for extended periods may affect device reliability.

# SN54AS825A, SN74AS825A 8-BIT BUS-INTERFACE FLIP-FLOPS WITH 3-STATE OUTPUTS

SDAS020B – JUNE 1984 – REVISED AUGUST 1995

## recommended operating conditions

|            |                                  | SN54AS825A                     |     |     | SN74AS825A |     |     | UNIT |
|------------|----------------------------------|--------------------------------|-----|-----|------------|-----|-----|------|
|            |                                  | MIN                            | NOM | MAX | MIN        | NOM | MAX |      |
| $V_{CC}$   | Supply voltage                   | 4.5                            | 5   | 5.5 | 4.5        | 5   | 5.5 | V    |
| $V_{IH}$   | High-level input voltage         | 2                              |     |     | 2          |     |     | V    |
| $V_{IL}$   | Low-level input voltage          |                                |     | 0.7 |            |     | 0.8 | V    |
| $I_{OH}$   | High-level output current        |                                |     | -24 |            |     | -24 | mA   |
| $I_{OL}$   | Low-level output current         |                                |     | 32  |            |     | 48  | mA   |
| $t_w^*$    | Pulse duration                   | $\overline{CLR}$ low           |     | 7   |            | 4   |     | ns   |
|            |                                  | CLK high or low                |     | 9.5 |            | 8   |     |      |
| $t_{su}^*$ | Setup time before CLK $\uparrow$ | $\overline{CLR}$ inactive      |     | 8   |            | 8   |     | ns   |
|            |                                  | Data                           |     | 7   |            | 6   |     |      |
|            |                                  | CLKEN high or low              |     | 10  |            | 6   |     |      |
| $t_h^*$    | Hold time after CLK $\uparrow$   | $\overline{CLKEN}$ low or data |     | 0   |            | 0   |     | ns   |
| $T_A$      | Operating free-air temperature   | -55                            |     | 125 | 0          |     | 70  | °C   |

\* On products compliant to MIL-STD-883, Class B, this parameter is based on characterization data but is not production tested.

## electrical characteristics over recommended operating free-air temperature range (unless otherwise noted)

| PARAMETER       | TEST CONDITIONS                           |                          | SN54AS825A   |      |      | SN74AS825A   |      |      | UNIT          |
|-----------------|---|--------------------------|--------------|------|------|--------------|------|------|---------------|
|                 |   |                          | MIN          | TYP† | MAX  | MIN          | TYP† | MAX  |               |
| $V_{IK}$        | $V_{CC} = 4.5\text{ V}$ ,                 | $I_I = -18\text{ mA}$    |              |      | -1.2 |              |      | -1.2 | V             |
| $V_{OH}$        | $V_{CC} = 4.5\text{ V to }5.5\text{ V}$ , | $I_{OH} = -2\text{ mA}$  | $V_{CC} - 2$ |      |      | $V_{CC} - 2$ |      |      | V             |
|                 | $V_{CC} = 4.5\text{ V}$                   | $I_{OH} = -15\text{ mA}$ | 2.4          | 3.2  |      | 2.4          | 3.2  |      |               |
|                 |   | $I_{OH} = -24\text{ mA}$ | 2            |      |      | 2            |      |      |               |
| $V_{OL}$        | $V_{CC} = 4.5\text{ V}$                   | $I_{OL} = 32\text{ mA}$  |              | 0.3  | 0.5  |              |      |      | V             |
|                 |   | $I_{OL} = 48\text{ mA}$  |              |      |      | 0.35         | 0.5  |      |               |
| $I_{OZH}$       | $V_{CC} = 5.5\text{ V}$ ,                 | $V_O = 2.7\text{ V}$     |              |      | 50   |              |      | 50   | $\mu\text{A}$ |
| $I_{OZL}$       | $V_{CC} = 5.5\text{ V}$ ,                 | $V_I = 0.4\text{ V}$     |              |      | -50  |              |      | -50  | $\mu\text{A}$ |
| $I_I$           | $V_{CC} = 5.5\text{ V}$ ,                 | $V_I = 7\text{ V}$       |              |      | 0.1  |              |      | 0.1  | mA            |
| $I_{IH}$        | $V_{CC} = 5.5\text{ V}$ ,                 | $V_I = 2.7\text{ V}$     |              |      | 20   |              |      | 20   | $\mu\text{A}$ |
| $I_{IL}$        | $V_{CC} = 5.5\text{ V}$ ,                 | $V_I = 0.4\text{ V}$     |              |      | -0.5 |              |      | -0.5 | mA            |
| $I_{O\ddagger}$ | $V_{CC} = 5.5\text{ V}$ ,                 | $V_O = 2.25\text{ V}$    | -30          |      | -112 | -30          |      | -112 | mA            |
| $I_{CC}$        | $V_{CC} = 5.5\text{ V}$                   | Outputs high             | 45           | 73   |      | 45           | 73   |      | mA            |
|                 |   | Outputs low              | 56           | 90   |      | 56           | 90   |      |               |
|                 |   | Outputs disabled         | 59           | 95   |      | 59           | 95   |      |               |

† All typical values are at  $V_{CC} = 5\text{ V}$ ,  $T_A = 25^\circ\text{C}$ .

‡ The output conditions have been chosen to produce a current that closely approximates one half of the true short-circuit output current,  $I_{OS}$ .

**SN54AS825A, SN74AS825A**  
**8-BIT BUS-INTERFACE FLIP-FLOPS**  
**WITH 3-STATE OUTPUTS**

SDAS020B – JUNE 1984 – REVISED AUGUST 1995

**switching characteristics (see Figure 1)**

| PARAMETER | FROM<br>(INPUT)         | TO<br>(OUTPUT) | $V_{CC} = 4.5\text{ V to }5.5\text{ V}$ ,<br>$C_L = 50\text{ pF}$ ,<br>$R_1 = 500\ \Omega$ ,<br>$R_2 = 500\ \Omega$ ,<br>$T_A = \text{MIN to MAX}^\dagger$ |      |            |      | UNIT |
|-----------|-------------------------|----------------|--|------|------------|------|------|
|           |                         |                | SN54AS825A   |      | SN74AS825A |      |      |
|           |                         |                | MIN  | MAX  | MIN        | MAX  |      |
| $t_{PLH}$ | CLK                     | Any Q          | 3.5  | 9    | 3.5        | 7.5  | ns   |
| $t_{PHL}$ |                         |                | 3.5  | 13.5 | 3.5        | 13   |      |
| $t_{PHL}$ | $\overline{\text{CLR}}$ | Any Q          | 3.5  | 16.5 | 3.5        | 15.5 | ns   |
| $t_{PZH}$ | $\overline{\text{OE}}$  | Any Q          | 4  | 12   | 4          | 11   | ns   |
| $t_{PZL}$ |                         |                | 4  | 13   | 4          | 12   |      |
| $t_{PHZ}$ | $\overline{\text{OE}}$  | Any Q          | 1  | 10   | 1.5        | 8    | ns   |
| $t_{PLZ}$ |                         |                | 1  | 10   | 1.5        | 8    |      |

<sup>†</sup> For conditions shown as MIN or MAX, use the appropriate value specified under recommended operating conditions.

# SN54AS825A, SN74AS825A 8-BIT BUS-INTERFACE FLIP-FLOPS WITH 3-STATE OUTPUTS

SDAS020B – JUNE 1984 – REVISED AUGUST 1995

## PARAMETER MEASUREMENT INFORMATION SERIES 54ALS/74ALS AND 54AS/74AS DEVICES

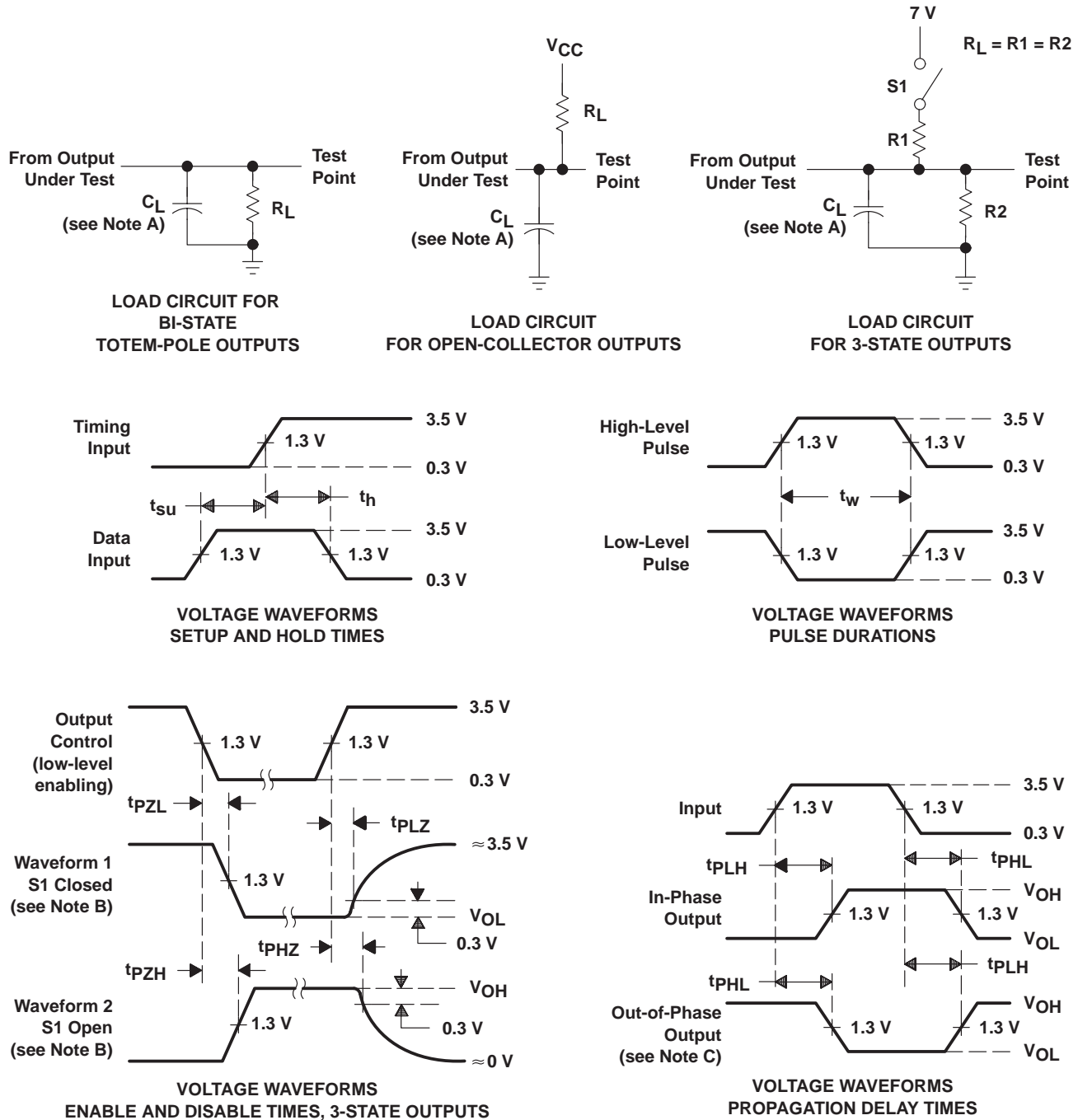

- NOTES: A.  $C_L$  includes probe and jig capacitance.  
 B. Waveform 1 is for an output with internal conditions such that the output is low except when disabled by the output control. Waveform 2 is for an output with internal conditions such that the output is high except when disabled by the output control.  
 C. When measuring propagation delay items of 3-state outputs, switch S1 is open.  
 D. All input pulses have the following characteristics:  $PRR \leq 1$  MHz,  $t_r = t_f = 2$  ns, duty cycle = 50%.  
 E. The outputs are measured one at a time with one transition per measurement.

Figure 1. Load Circuits and Voltage Waveforms

## IMPORTANT NOTICE

Texas Instruments and its subsidiaries (TI) reserve the right to make changes to their products or to discontinue any product or service without notice, and advise customers to obtain the latest version of relevant information to verify, before placing orders, that information being relied on is current and complete. All products are sold subject to the terms and conditions of sale supplied at the time of order acknowledgement, including those pertaining to warranty, patent infringement, and limitation of liability.

TI warrants performance of its semiconductor products to the specifications applicable at the time of sale in accordance with TI's standard warranty. Testing and other quality control techniques are utilized to the extent TI deems necessary to support this warranty. Specific testing of all parameters of each device is not necessarily performed, except those mandated by government requirements.

CERTAIN APPLICATIONS USING SEMICONDUCTOR PRODUCTS MAY INVOLVE POTENTIAL RISKS OF DEATH, PERSONAL INJURY, OR SEVERE PROPERTY OR ENVIRONMENTAL DAMAGE ("CRITICAL APPLICATIONS"). TI SEMICONDUCTOR PRODUCTS ARE NOT DESIGNED, AUTHORIZED, OR WARRANTED TO BE SUITABLE FOR USE IN LIFE-SUPPORT DEVICES OR SYSTEMS OR OTHER CRITICAL APPLICATIONS. INCLUSION OF TI PRODUCTS IN SUCH APPLICATIONS IS UNDERSTOOD TO BE FULLY AT THE CUSTOMER'S RISK.

In order to minimize risks associated with the customer's applications, adequate design and operating safeguards must be provided by the customer to minimize inherent or procedural hazards.

TI assumes no liability for applications assistance or customer product design. TI does not warrant or represent that any license, either express or implied, is granted under any patent right, copyright, mask work right, or other intellectual property right of TI covering or relating to any combination, machine, or process in which such semiconductor products or services might be or are used. TI's publication of information regarding any third party's products or services does not constitute TI's approval, warranty or endorsement thereof.