

阅读申明

- 1.本站收集的数据手册和产品资料都来自互联网，版权归原作者所有。如读者和版权方有任何异议请及时告之，我们将妥善解决。
- 2.本站提供的中文数据手册是英文数据手册的中文翻译，其目的是协助用户阅读，该译文无法自动跟随原稿更新，同时也可能存在翻译上的不当。建议读者以英文原稿为参考以便获得更精准的信息。
- 3.本站提供的产品资料，来自厂商的技术支持或者使用者的心得体会等，其内容可能存在描述上的差异，建议读者做出适当判断。
- 4.如需与我们联系，请发邮件到marketing@iczoom.com，主题请标有“数据手册”字样。

Read Statement

1. The datasheets and other product information on the site are all from network reference or other public materials, and the copyright belongs to the original author and original published source. If readers and copyright owners have any objections, please contact us and we will deal with it in a timely manner.
2. The Chinese datasheets provided on the website is a Chinese translation of the English datasheets. Its purpose is for reader's learning exchange only and do not involve commercial purposes. The translation cannot be automatically updated with the original manuscript, and there may also be improper translations. Readers are advised to use the English manuscript as a reference for more accurate information.
3. All product information provided on the website refer to solutions from manufacturers' technical support or users the contents may have differences in description, and readers are advised to take the original article as the standard.
4. If you have any questions, please contact us at marketing@iczoom.com and mark the subject with "Datasheets" .

TOSHIBA CMOS Digital Integrated Circuit Silicon Monolithic

TC74ACT573P, TC74ACT573F, TC74ACT573FW, TC74ACT573FT

Octal D-Type Latch with 3-State Output

The TC74ACT573 is an advanced high speed CMOS OCTAL LATCH fabricated with silicon gate and double-layer metal wiring C²MOS technology.

It achieves the high speed operation similar to equivalent Bipolar Schottky TTL while maintaining the CMOS low power dissipation.

This device may be used as a level converter for interfacing TTL or NMOS to High Speed CMOS. The inputs are compatible with TTL, NMOS and CMOS output voltage levels.

These 8-bit D-type latches are controlled by a latch enable (LE) and a output enable input (OE).

When the OE input is high, the eight outputs are in a high impedance state.

All inputs are equipped with protection circuits against static discharge or transient excess voltage.

Features

- High speed: $t_{pd} = 5.5 \text{ ns (typ.)}$ at $V_{CC} = 5 \text{ V}$
- Low power dissipation: $I_{CC} = 8 \mu\text{A (max)}$ at $T_a = 25^\circ\text{C}$
- Compatible with TTL outputs: $V_{IL} = 0.8 \text{ V (max)}$
 $V_{IH} = 2.0 \text{ V (min)}$
- Symmetrical output impedance: $|I_{OH}| = I_{OL} = 24 \text{ mA (min)}$
Capability of driving 50Ω transmission lines.
- Balanced propagation delays: $t_{pLH} \approx t_{pHL}$
- Pin and function compatible with 74F573

Note: xxxFW (JEDEC SOP) is not available in Japan.

TC74ACT573P

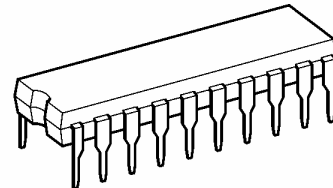

DIP20-P-300-2.54A

TC74ACT573F

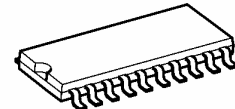

SOP20-P-300-1.27A

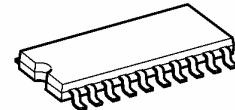

SOP20-P-300-1.27

TC74ACT573FW

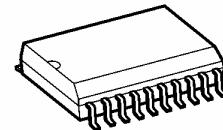

SOL20-P-300-1.27

TC74ACT573FT

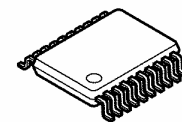

TSSOP20-P-0044-0.65A

Weight	
DIP20-P-300-2.54A	: 1.30 g (typ.)
SOP20-P-300-1.27A	: 0.22 g (typ.)
SOP20-P-300-1.27	: 0.22 g (typ.)
SOL20-P-300-1.27	: 0.46 g (typ.)
TSSOP20-P-0044-0.65A	: 0.08 g (typ.)

Pin Assignment

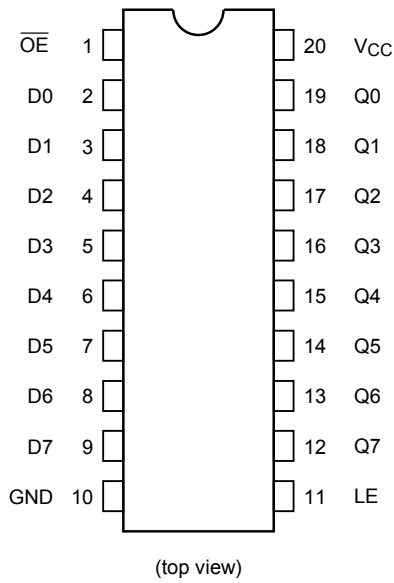

IEC Logic Symbol

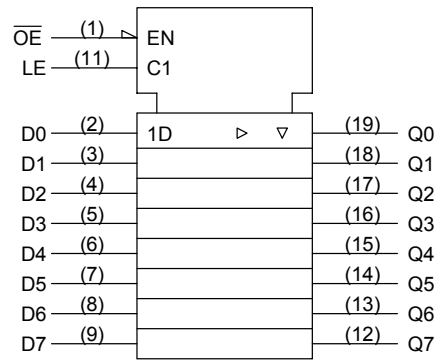

Truth Table

Inputs			Output
\overline{OE}	LE	D	Q
H	X	X	Z
L	L	X	Q_n
L	H	L	L
L	H	H	H

X: Don't care

Z: High impedance

Q_n : Q outputs are latched at the time when the LE input is taken to a low logic level.

System Diagram

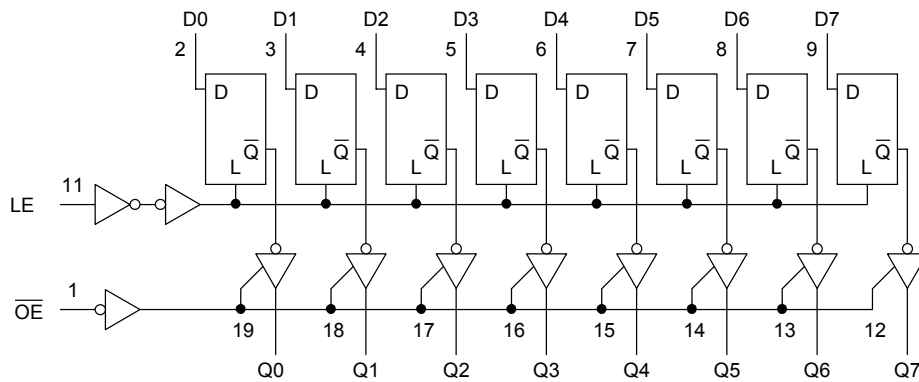

Absolute Maximum Ratings (Note 1)

Characteristics	Symbol	Rating	Unit
Supply voltage range	V_{CC}	-0.5 to 7.0	V
DC input voltage	V_{IN}	-0.5 to $V_{CC} + 0.5$	V
DC output voltage	V_{OUT}	-0.5 to $V_{CC} + 0.5$	V
Input diode current	I_{IK}	± 20	mA
Output diode current	I_{OK}	± 50	mA
DC output current	I_{OUT}	± 50	mA
DC V_{CC} /ground current	I_{CC}	± 200	mA
Power dissipation	P_D	500 (DIP) (Note 2)/180 (SOP/TSSOP)	mW
Storage temperature	T_{stg}	-65 to 150	$^{\circ}C$

Note1: Exceeding any of the absolute maximum ratings, even briefly, lead to deterioration in IC performance or even destruction.

Note2: 500 mW in the range of $T_a = -40$ to $65^{\circ}C$. From $T_a = 65$ to $85^{\circ}C$ a derating factor of -10 mW/ $^{\circ}C$ should be applied up to 300 mW.

Recommended Operating Conditions (Note)

Characteristics	Symbol	Rating	Unit
Supply voltage	V_{CC}	4.5 to 5.5	V
Input voltage	V_{IN}	0 to V_{CC}	V
Output voltage	V_{OUT}	0 to V_{CC}	V
Operating temperature	T_{opr}	-40 to 85	$^{\circ}C$
Input rise and fall time	dt/dV	0 to 10	ns/V

Note: The recommended operating conditions are required to ensure the normal operation of the device. Unused inputs must be tied to either VCC or GND.

Electrical Characteristics

DC Characteristics

Characteristics	Symbol	Test Condition		Ta = 25°C			Ta = -40 to 85°C		Unit	
				V _{CC} (V)	Min	Typ.	Max	Min		Max
High-level input voltage	V _{IH}	—		4.5 to 5.5	2.0	—	—	2.0	—	V
Low-level input voltage	V _{IL}	—		4.5 to 5.5	—	—	0.8	—	0.8	V
High-level output voltage	V _{OH}	V _{IN} = V _{IH} or V _{IL}	I _{OH} = -50 μA	4.5	4.4	4.5	—	4.4	—	V
			I _{OH} = -24 mA	4.5	3.94	—	—	3.80	—	
			I _{OH} = -75 mA (Note)	5.5	—	—	—	3.85	—	
Low-level output voltage	V _{OL}	V _{IN} = V _{IH} or V _{IL}	I _{OL} = 50 μA	4.5	—	0.0	0.1	—	0.1	V
			I _{OL} = 24 mA	4.5	—	—	0.36	—	0.44	
			I _{OL} = 75 mA (Note)	5.5	—	—	—	—	1.65	
3-state output off-state current	I _{OZ}	V _{IN} = V _{IH} or V _{IL} V _{OUT} = V _{CC} or GND		5.5	—	—	±0.5	—	±5.0	μA
Input leakage current	I _{IN}	V _{IN} = V _{CC} or GND		5.5	—	—	±0.1	—	±1.0	μA
Quiescent supply current	I _{CC}	V _{IN} = V _{CC} or GND		5.5	—	—	8.0	—	80.0	μA
	I _C	Per input: V _{IN} = 3.4 V Other input: V _{CC} or GND		5.5	—	—	1.35	—	1.5	mA

Note: This spec indicates the capability of driving 50 Ω transmission lines.

One output should be tested at a time for a 10 ms maximum duration.

Timing Requirements (input: t_r = t_f = 3 ns)

Characteristics	Symbol	Test Condition	V _{CC} (V)	Ta = 25°C	Ta = -40 to 85°C	Unit
			Limit	Limit		
Minimum pulse width (LE)	t _w (H)	—	5.0 ± 0.5	5.0	5.0	ns
Minimum set-up time	t _s	—	5.0 ± 0.5	3.0	3.0	ns
Minimum hold time	t _h	—	5.0 ± 0.5	2.0	2.0	ns

AC Characteristics ($C_L = 50 \text{ pF}$, $R_L = 500 \text{ } \Omega$, input: $t_r = t_f = 3 \text{ ns}$)

Characteristics	Symbol	Test Condition	Ta = 25°C			Ta = -40 to 85°C		Unit	
			V _{CC} (V)	Min	Typ.	Max	Min		Max
Propagation delay time (LE-Q)	t _{pLH} t _{pHL}	—	5.0 ± 0.5	—	6.3	10.5	1.0	12.0	ns
Propagation delay time (Dn-Q)	t _{pLH} t _{pHL}	—	5.0 ± 0.5	—	6.2	9.6	1.0	11.0	ns
Output enable time	t _{pZL} t _{pZH}	—	5.0 ± 0.5	—	6.5	10.0	1.0	11.5	ns
Output disable time	t _{pLZ} t _{pHZ}	—	5.0 ± 0.5	—	6.5	8.8	1.0	10.0	ns
Input capacitance	C _{IN}	—	—	5	10	—	10	pF	
Output capacitance	C _{OUT}	—	—	10	—	—	—	pF	
Power dissipation capacitance	C _{PD}	(Note)	—	22	—	—	—	pF	

Note: C_{PD} is defined as the value of the internal equivalent capacitance which is calculated from the operating current consumption without load.

Average operating current can be obtained by the equation:

$$I_{CC (opr)} = C_{PD} \cdot V_{CC} \cdot f_{IN} + I_{CC}/8 \text{ (per latch)}$$

And the total C_{PD} when n pcs. of latch operate can be gained by the following equation:

$$C_{PD (total)} = 6 + 16 \cdot n$$

Package Dimensions

DIP20-P-300-2.54A

Unit : mm

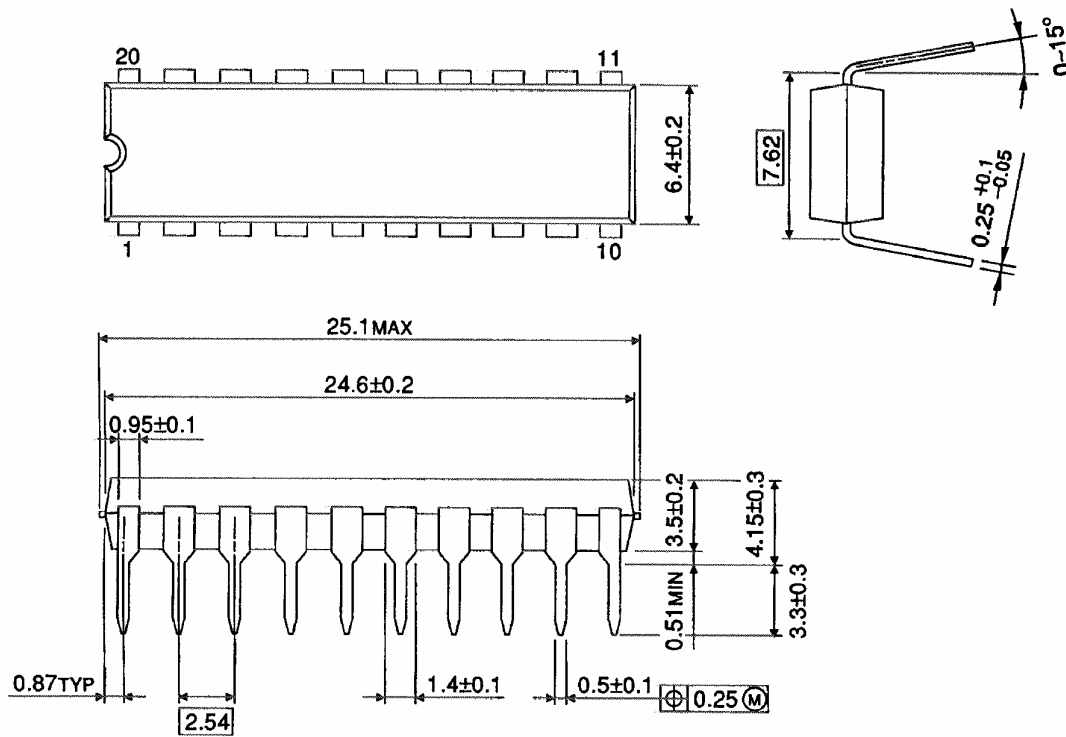

Weight: 1.30 g (typ.)

Package Dimensions

SOP20-P-300-1.27A

Unit: mm

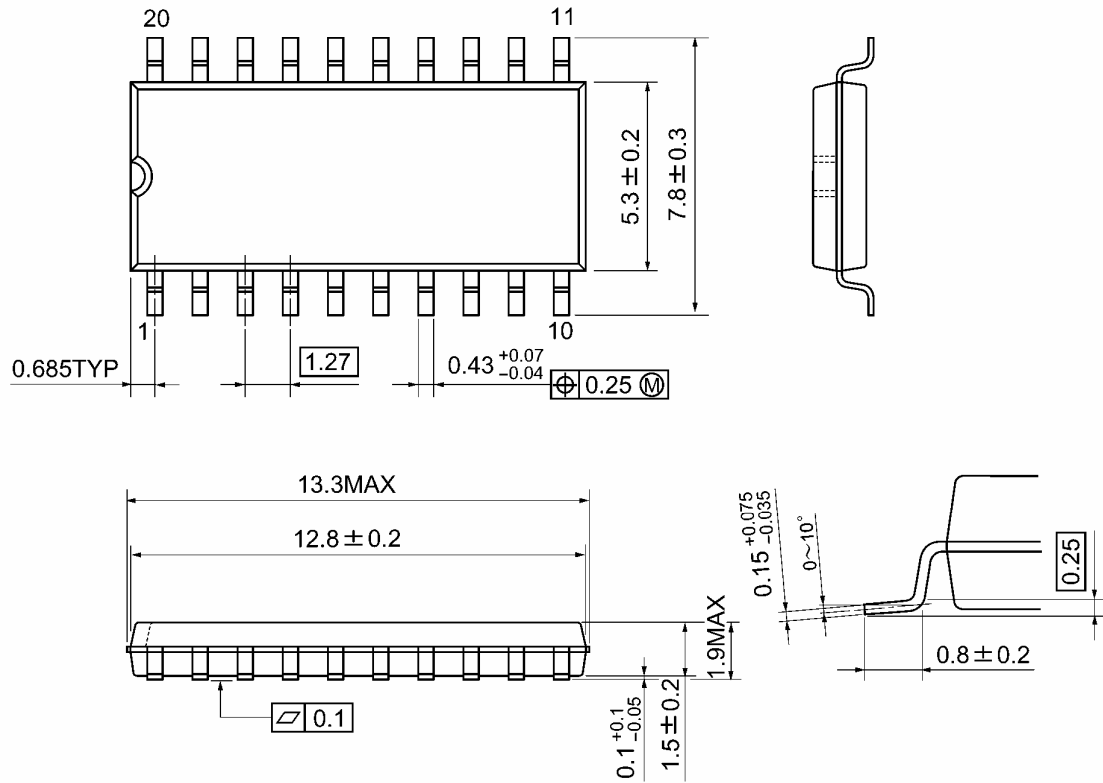

Weight: 0.22 g (typ.)

Package Dimensions

SOP20-P-300-1.27

Unit : mm

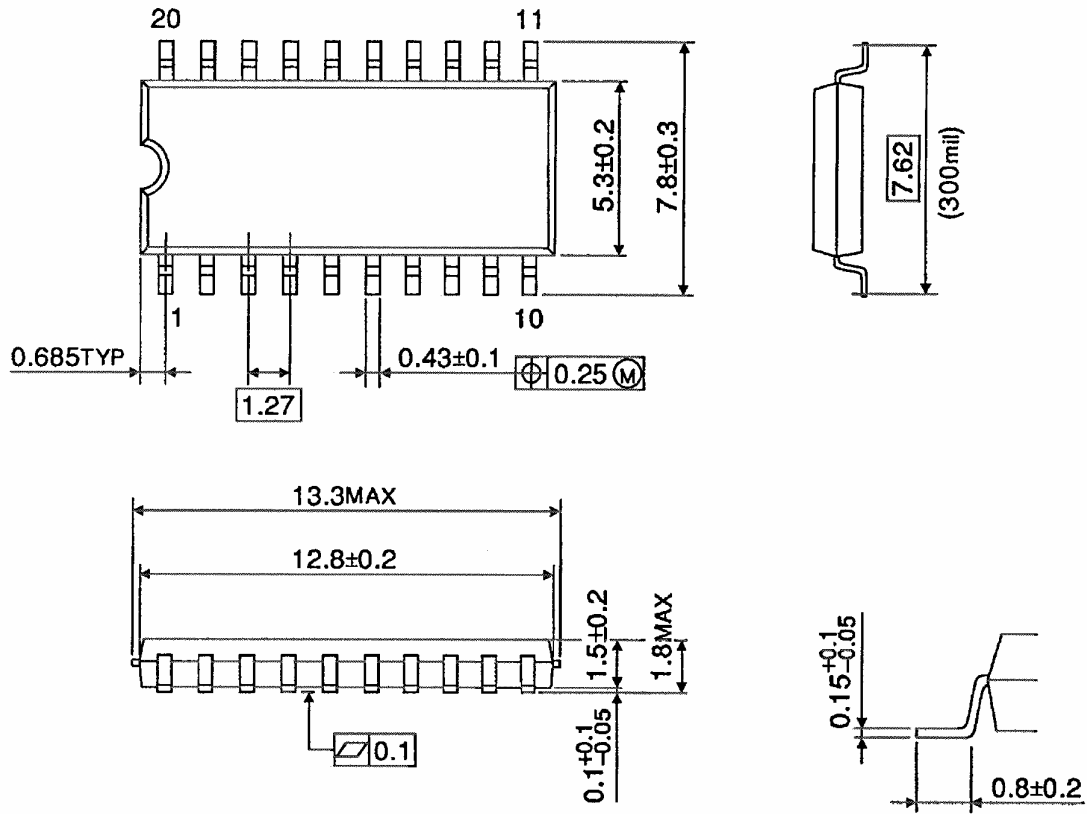

Weight: 0.22 g (typ.)

Package Dimensions (Note)

SOL20-P-300-1.27

Unit : mm

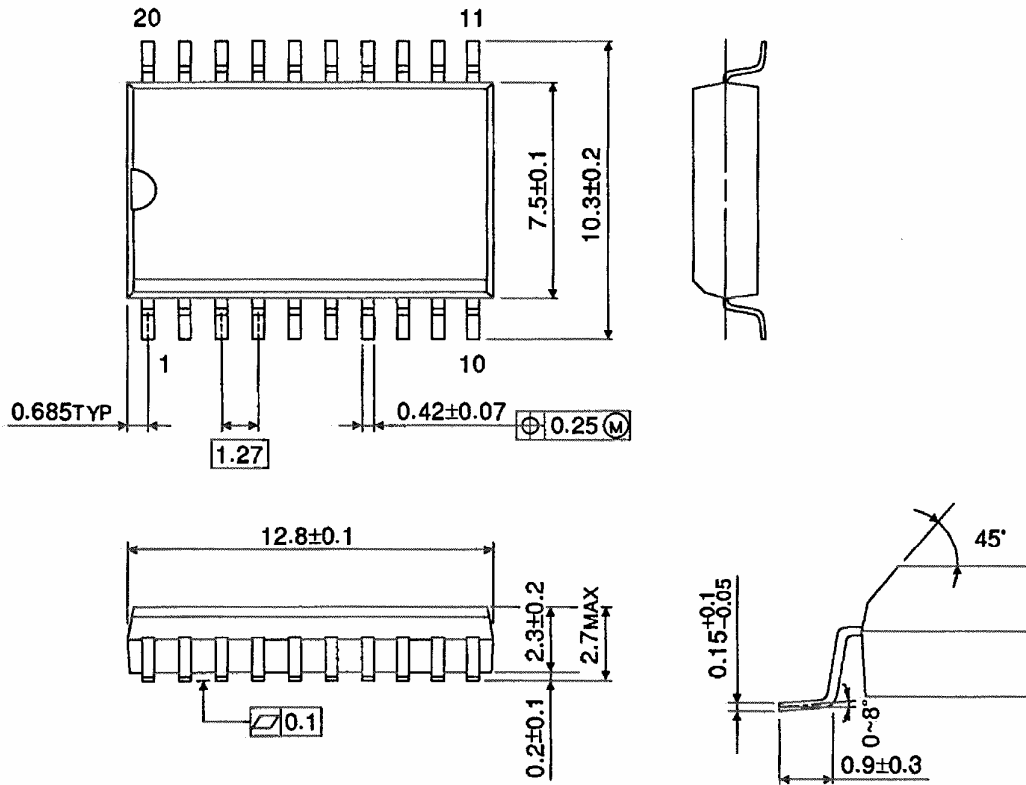

Note: This package is not available in Japan.

Weight: 0.46 g (typ.)

Package Dimensions

TSSOP20-P-0044-0.65A

Unit: mm

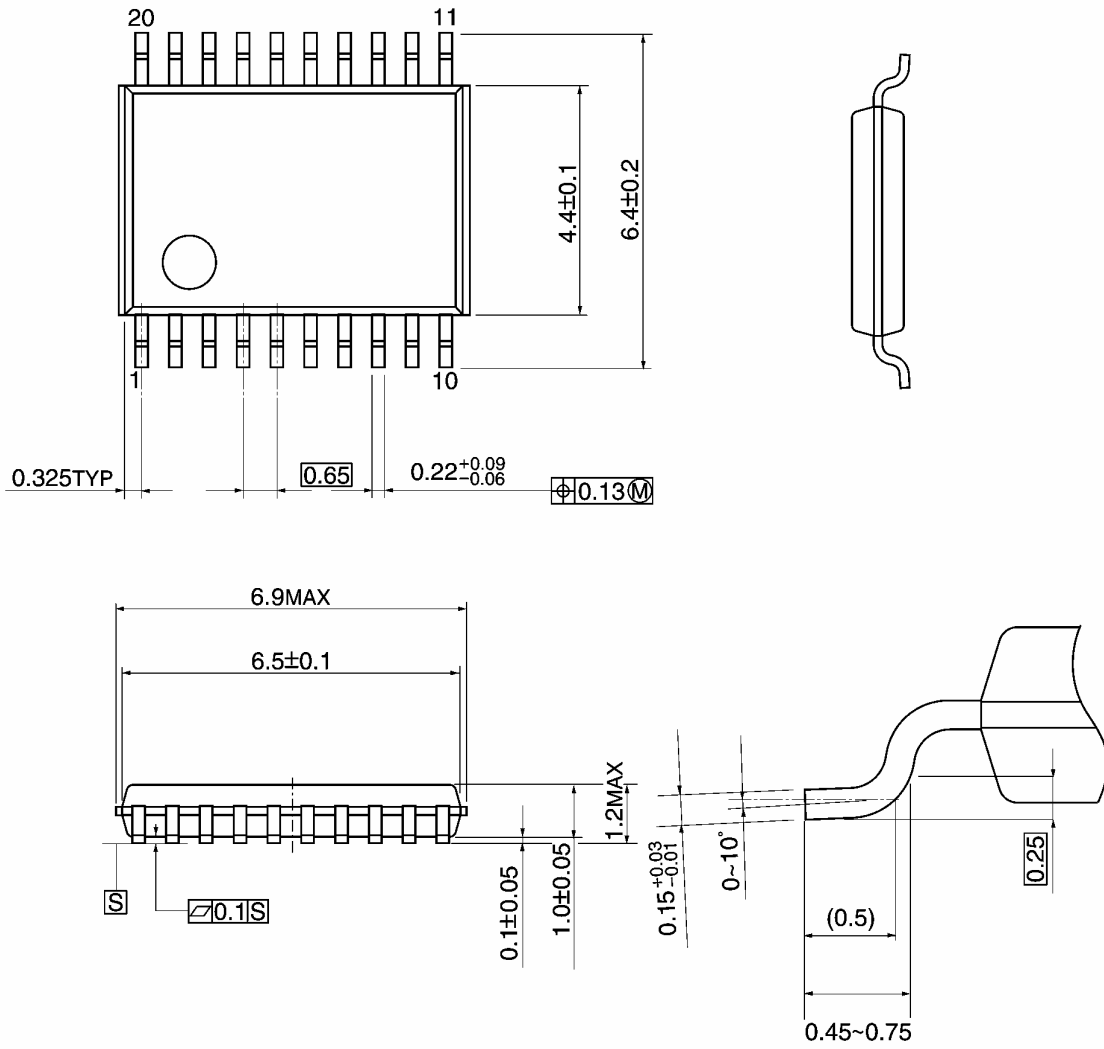

Weight: 0.08 g (typ.)

Note: Lead (Pb)-Free Packages**DIP20-P-300-2.54A SOP20-P-300-1.27A TSSOP20-P-0044-0.65A****RESTRICTIONS ON PRODUCT USE**

060116EBA

- The information contained herein is subject to change without notice. 021023_D
- TOSHIBA is continually working to improve the quality and reliability of its products. Nevertheless, semiconductor devices in general can malfunction or fail due to their inherent electrical sensitivity and vulnerability to physical stress. It is the responsibility of the buyer, when utilizing TOSHIBA products, to comply with the standards of safety in making a safe design for the entire system, and to avoid situations in which a malfunction or failure of such TOSHIBA products could cause loss of human life, bodily injury or damage to property.
In developing your designs, please ensure that TOSHIBA products are used within specified operating ranges as set forth in the most recent TOSHIBA products specifications. Also, please keep in mind the precautions and conditions set forth in the "Handling Guide for Semiconductor Devices," or "TOSHIBA Semiconductor Reliability Handbook" etc. 021023_A
- The TOSHIBA products listed in this document are intended for usage in general electronics applications (computer, personal equipment, office equipment, measuring equipment, industrial robotics, domestic appliances, etc.). These TOSHIBA products are neither intended nor warranted for usage in equipment that requires extraordinarily high quality and/or reliability or a malfunction or failure of which may cause loss of human life or bodily injury ("Unintended Usage"). Unintended Usage include atomic energy control instruments, airplane or spaceship instruments, transportation instruments, traffic signal instruments, combustion control instruments, medical instruments, all types of safety devices, etc. Unintended Usage of TOSHIBA products listed in this document shall be made at the customer's own risk. 021023_B
- The products described in this document shall not be used or embedded to any downstream products of which manufacture, use and/or sale are prohibited under any applicable laws and regulations. 060106_Q
- The information contained herein is presented only as a guide for the applications of our products. No responsibility is assumed by TOSHIBA for any infringements of patents or other rights of the third parties which may result from its use. No license is granted by implication or otherwise under any patent or patent rights of TOSHIBA or others. 021023_C
- The products described in this document are subject to the foreign exchange and foreign trade laws. 021023_E