

阅读申明

- 1.本站收集的数据手册和产品资料都来自互联网，版权归原作者所有。如读者和版权方有任何异议请及时告之，我们将妥善解决。
- 2.本站提供的中文数据手册是英文数据手册的中文翻译，其目的是协助用户阅读，该译文无法自动跟随原稿更新，同时也可能存在翻译上的不当。建议读者以英文原稿为参考以便获得更精准的信息。
- 3.本站提供的产品资料，来自厂商的技术支持或者使用者的心得体会等，其内容可能存在描述上的差异，建议读者做出适当判断。
- 4.如需与我们联系，请发邮件到marketing@iczoom.com，主题请标有“数据手册”字样。

Read Statement

1. The datasheets and other product information on the site are all from network reference or other public materials, and the copyright belongs to the original author and original published source. If readers and copyright owners have any objections, please contact us and we will deal with it in a timely manner.
2. The Chinese datasheets provided on the website is a Chinese translation of the English datasheets. Its purpose is for reader's learning exchange only and do not involve commercial purposes. The translation cannot be automatically updated with the original manuscript, and there may also be improper translations. Readers are advised to use the English manuscript as a reference for more accurate information.
3. All product information provided on the website refer to solutions from manufacturers' technical support or users the contents may have differences in description, and readers are advised to take the original article as the standard.
4. If you have any questions, please contact us at marketing@iczoom.com and mark the subject with "Datasheets" .

XC74WL157ASR



CMOS Logic

CMOS Logic 2-channel Multiplexer
Operating Voltage Range : 2V ~ 5.5V
High Speed Operations : tpd = 4.1ns(TYP.)
Low Power Consumption : 2 μ A(MAX.)
MSOP-8B Package

APPLICATIONS

Palmtops
Digital equipment

GENERAL DESCRIPTION

XC74WL157ASR is 2-channel multiplexer manufactured using silicon gate CMOS processes. The small quiescent current, which is one of the features of the CMOS logic, gives way to high speed operations which enables LS-TTL.

With wave forming buffers connected internally, stabilized output can be achieved as the series offers high noise immunity.

As the series is integrated into a mini molded, MSOP-8B package, high density mounting is possible.

FEATURES

High Speed Operations : tpd = 4.1ns(TYP.) (VCC=5V)
Operating Voltage Range : 2V ~ 5.5V
Low Power Consumption: 2 μ A (MAX.)
Small Package : MSOP-8B

PIN CONFIGURATION

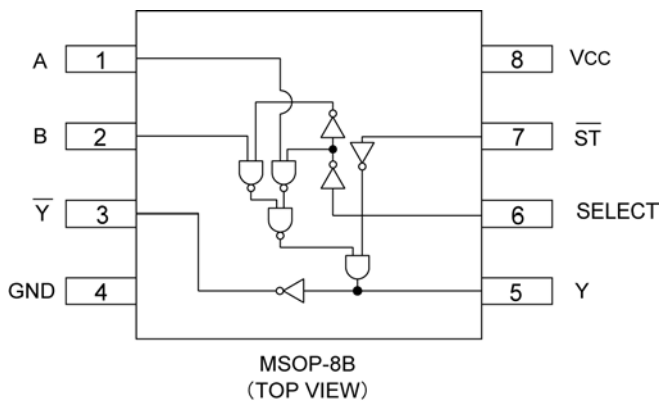

FUNCTIONS

INPUT				OUTPUT	
ST	SELECT	A	B	Y	Y
H	X	X	X	L	H
L	L	L	X	L	H
L	L	H	X	H	L
L	H	X	L	L	H
L	H	X	H	H	L

H=High level

L=Low level

X=Don't care

XC74WL157ASR

ABSOLUTE MAXIMUM RATINGS

Ta=-40 ~85

PARAMETER	SYMBOL	RATINGS	UNITS
Supply Voltage	V _{CC}	-0.5~+6.0	V
Input Voltage	V _{IN}	-0.5~+6.0	V
Output Voltage	V _{OUT}	-0.5~V _{CC} +0.5	V
Input Diode Current	I _{IK}	-20	mA
Output Diode Current	I _{OK}	± 20	mA
Switch Output Current	I _{OUT}	± 25	mA
V _{CC} ,GND Current	I _{CC} ,I _{GND}	± 50	mA
Power Dissipation (Ta = 25)	P _d	300	mW
Storage Temperature Range	T _{stg}	-65~+150	

Note : Voltage is all ground standardized.

RECOMMENDED OPERATING CONDITIONS

PARAMETER	SYMBOL	CONDITIONS	UNITS
Supply Voltage	V _{CC}	2~5.5	V
Input Voltage	V _{IN}	0~5.5	V
Output Voltage	V _{OUT}	0~V _{CC}	V
Operating Temperature Range	T _{opr}	-40~+85	
Input Rise and Fall Time	tr, tf	0~200 (V _{CC} =3.3V)	ns
		0~100 (V _{CC} =5V)	

DC ELECTRICAL CHARACTERISTICS

PARAMETER	SYMBOL	V _{CC} (V)	CONDITIONS	Ta=25			Ta=-40 ~85		UNITS	
				MIN.	TYP.	MAX.	MIN.	MAX.		
Input Voltage	V _{IH}	2.0		1.50	-	-	1.50	-	V	
		3.0		2.10	-	-	2.10	-		
		5.5		3.85	-	-	3.85	-		
	V _{IL}	2.0		-	-	0.50	-	0.50	V	
		3.0		-	-	0.90	-	0.90		
		5.5		-	-	1.65	-	1.65		
Output Voltage	V _{OH}	2.0	V _{IN} =V _{IH}	I _{OH} =-50 μ A	1.90	2.00	-	1.90	-	V
		3.0			2.90	3.00	-	2.90	-	
		4.5			4.40	4.50	-	4.40	-	
		3.0		I _{OH} =-4mA	2.58	-	-	2.48	-	
		4.5		I _{OH} =-8mA	3.94	-	-	3.80	-	
		2.0		V _{IN} =V _{IL}	I _{OL} =50 μ A	-	-	0.10	-	
	3.0	-	-			0.10	-	0.10		
	4.5	-	-			0.10	-	0.10		
	3.0	I _{OL} =4mA	-		-	0.36	-	0.44		
	4.5	I _{OL} =8mA	-		-	0.36	-	0.44		
	Input Current	I _{IN}	0~5.5		V _{IN} =V _{CC} or GND	-0.10	-	0.10	-1.00	1.00
	Static Supply Current	I _{CC}	5.5	V _{IN} =V _{CC} or GND	-	-	2.00	-	20.0	μ A

SWITCHING ELECTRICAL CHARACTERISTICS

(tr=tf=3ns)

PARAMETER	SYMBOL	CONDITIONS		Ta=25			Ta=-40 ~85		UNITS
		CL	Vcc(V)	MIN.	TYP.	MAX.	MIN.	MAX.	
Delay Time (A, B-Y, \overline{Y})	tPLH	15pF	3.3	-	6.2	9.7	1.0	11.5	ns
			5.0	-	4.1	6.4	1.0	7.5	
		50pF	3.3	-	8.7	13.2	1.0	15.0	ns
			5.0	-	5.6	8.4	1.0	9.5	
	tPHL	15pF	3.3	-	6.2	9.7	1.0	11.5	ns
			5.0	-	4.1	6.4	1.0	7.5	
		50pF	3.3	-	8.7	13.2	1.0	15.0	ns
			5.0	-	5.6	8.4	1.0	9.5	
Delay Time (SEDECT-Y, \overline{Y})	tPLH	15pF	3.3	-	8.4	13.2	1.0	15.5	ns
			5.0	-	5.3	8.1	1.0	9.5	
		50pF	3.3	-	10.9	16.7	1.0	19.0	ns
			5.0	-	6.8	10.1	1.0	11.5	
	tPHL	15pF	3.3	-	8.4	13.2	1.0	15.5	ns
			5.0	-	5.3	8.1	1.0	9.5	
		50pF	3.3	-	10.9	16.7	1.0	19.0	ns
			5.0	-	6.8	10.1	1.0	11.5	
Delay Time (\overline{ST} -Y, Y)	tPLH	15pF	3.3	-	8.7	13.6	1.0	16.0	ns
			5.0	-	5.6	8.6	1.0	10.0	
		50pF	3.3	-	11.2	17.1	1.0	19.5	ns
			5.0	-	7.1	10.6	1.0	12.0	
	tPHL	15pF	3.3	-	8.7	13.6	1.0	16.0	ns
			5.0	-	5.6	8.6	1.0	10.0	
		50pF	3.3	-	11.2	17.1	1.0	19.5	ns
			5.0	-	7.1	10.6	1.0	12.0	
Input Capacitance	CIN	-	-	-	4	10	-	10	pF
Power Dissipation Capacitance	Cpd	-	-	-	20	-	-	-	pF

NOISE CHARACTERISTICS

(tr=tf=3ns)

PARAMETER	SYMBOL	CONDITIONS		Ta=25			UNITS
		CL	Vcc(V)	MIN.	TYP.	MAX.	
Non Functional Output Maximum Dynamic VOL	VOLP	50pF	5.0	-	0.3	0.8	V
Non Functional Output Minimum Dynamic VOL	VOLV	50pF	5.0	-0.8	-0.3	-	V
Minimum Dynamic VIH	VIHD	50pF	5.0	-	-	3.5	V
Maximum Dynamic VIL	VILD	50pF	5.0	-	-	1.5	V

XC74WL157ASR

TEST CIRCUIT

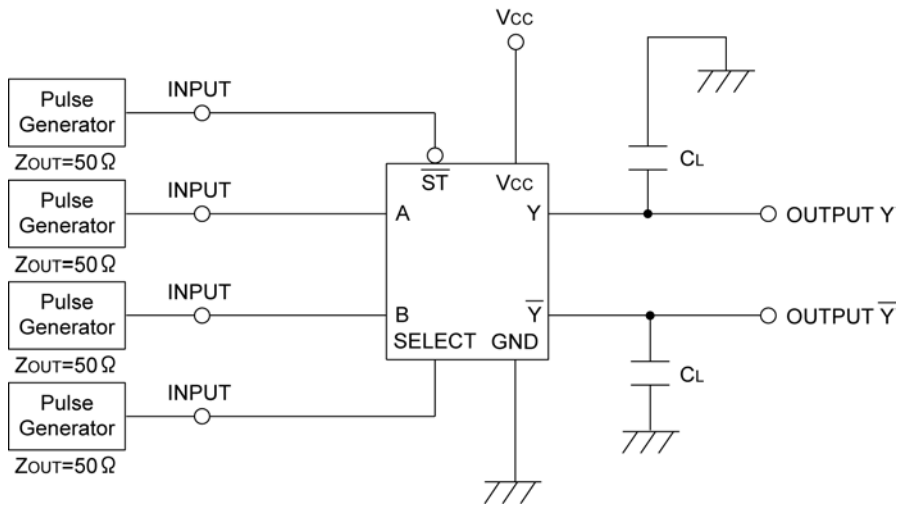

WAVEFORM

