

阅读申明

- 1.本站收集的数据手册和产品资料都来自互联网，版权归原作者所有。如读者和版权方有任何异议请及时告之，我们将妥善解决。
- 2.本站提供的中文数据手册是英文数据手册的中文翻译，其目的是协助用户阅读，该译文无法自动跟随原稿更新，同时也可能存在翻译上的不当。建议读者以英文原稿为参考以便获得更精准的信息。
- 3.本站提供的产品资料，来自厂商的技术支持或者使用者的心得体会等，其内容可能存在描述上的差异，建议读者做出适当判断。
- 4.如需与我们联系，请发邮件到marketing@iczoom.com，主题请标有“数据手册”字样。

Read Statement

1. The datasheets and other product information on the site are all from network reference or other public materials, and the copyright belongs to the original author and original published source. If readers and copyright owners have any objections, please contact us and we will deal with it in a timely manner.
2. The Chinese datasheets provided on the website is a Chinese translation of the English datasheets. Its purpose is for reader's learning exchange only and do not involve commercial purposes. The translation cannot be automatically updated with the original manuscript, and there may also be improper translations. Readers are advised to use the English manuscript as a reference for more accurate information.
3. All product information provided on the website refer to solutions from manufacturers' technical support or users the contents may have differences in description, and readers are advised to take the original article as the standard.
4. If you have any questions, please contact us at marketing@iczoom.com and mark the subject with "Datasheets" .

100325 Low Power Hex ECL-to-TTL Translator

General Description

The 100325 is a hex translator for converting F100K logic levels to TTL logic levels. Differential inputs allow each circuit to be used as an inverting, non-inverting or differential receiver. An internal reference voltage generator provides V_{BB} for single-ended operation, or for use in Schmitt trigger applications. All inputs have $50k\Omega$ pull-down resistors. When the inputs are either unconnected or at the same potential the outputs will go LOW.

When used in single-ended operation the apparent input threshold of the true inputs is 20mV to 40mV higher (positive) than the threshold of the complementary inputs. The V_{EE} and V_{TTL} power may be applied in either order.

Features

- Pin/function compatible with 100125
- Meets 100125 AC specifications
- 50% power reduction of the 100125
- Differential inputs with built in offset
- Standard FAST® outputs
- 2000V ESD protection
- -4.2V to -5.7V operating range
- Available to industrial grade temperature range

Ordering Code:

Order Number	Package Number	Package Description
100325SC	M24B	24-Lead Small Outline Integrated Circuit (SOIC), JEDEC MS-013, 0.300 Wide
100325PC	N24E	24-Lead Plastic Dual-In-Line Package (PDIP), JEDEC MS-010, 0.400 Wide
100325QI	V28A	28-Lead Plastic Lead Chip Carrier (PLCC), JEDEC MO-047, 0.450 Square
100325QC	V28A	28-Lead Plastic Lead Chip Carrier (PLCC), JEDEC MO-047, 0.450 Square Industrial Temperature Range (-40°C to +85°C)

Devices also available in Tape and Reel. Specify by appending the suffix letter "X" to the ordering code.

Connection Diagrams

24-Pin DIP/SOIC

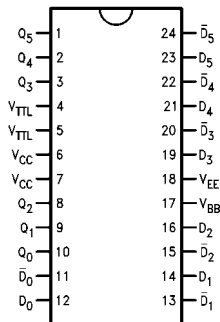

28-Pin PLCC

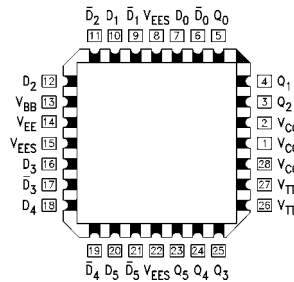

Pin Descriptions

Pin Names	Description
D_0 - D_5	Data Inputs
\bar{D}_0 - \bar{D}_5	Inverting Data Inputs
Q_0 - Q_5	Data Outputs

FAST® is a registered trademark of Fairchild Semiconductor Corporation.

100325

Truth Table

Inputs		Outputs
D_n	\overline{D}_n	Q_n
L	H	L
H	L	H
L	L	L
H	H	L
OPEN	OPEN	L
V_{EE}	V_{EE}	L
L	V_{BB}	L
H	V_{BB}	H
V_{BB}	L	H
V_{BB}	H	L

H = HIGH Voltage Level
L = LOW Voltage Level

Logic Diagram

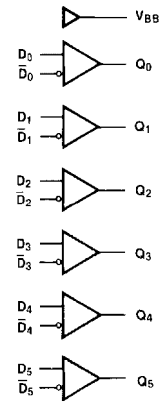

Absolute Maximum Ratings ^(Note 1)				Recommended Operating Conditions					
Storage Temperature (T_{STG})	-65°C to +150°C			Case Temperature (T_C)	Commercial 0°C to +85°C				
Maximum Junction Temperature (T_J)	+150°C			Industrial	-40°C to +85°C				
V_{EE} Pin Potential to Ground Pin	-7.0V to +0.5V			Supply Voltage (V_{EE})	-5.7V to -4.2V				
V_{TTL} Pin Potential to Ground Pin	-0.5V to +6.0V								
Input Voltage (DC)	V_{EE} to +0.5V								
Voltage Applied to Output									
in HIGH State (with $V_{CC} = 0V$)	-0.5V to V_{CC}								
Current Applied to Output									
in LOW State (Max)	twice the rated I_{OL} (mA)								
ESD (Note 2)	≥2000V								
<p>Note 1: The "Absolute Maximum Ratings" are those values beyond which the safety of the device cannot be guaranteed. The device should not be operated at these limits. The parametric values defined in the Electrical Characteristics tables are not guaranteed at the absolute maximum rating. The "Recommended Operating Conditions" table will define the conditions for actual device operation.</p> <p>Note 2: ESD testing conforms to MIL-STD-883, Method 3015.</p>									
Commercial Version									
DC Electrical Characteristics									
$V_{EE} = -4.2V$ to $-5.7V$, $V_{CC} = GND$, $V_{TTL} = +4.5V$ to $5.5V$, $T_C = 0°C$ to $+85°C$ (Note 3)									
Symbol	Parameter	Min	Typ	Max	Units	Conditions			
V_{BB}	Output Reference Voltage	-1380	-1320	-1260	mV	$I_{VBB} = -2.1$ mA			
V_{IH}	Single-Ended Input HIGH Voltage	-1165		-870	mV	Guaranteed HIGH Signal for All Inputs (with One Input Tied to V_{BB})			
V_{IL}	Single-Ended Input LOW Voltage	-1830		-1475	mV	Guaranteed LOW Signal for All Inputs (with One Input Tied to V_{BB})			
V_{OH}	Output HIGH Voltage	2.5			V	$I_{OH} = -2.0$ mA	$V_{IN} = V_{IH} (Max)$		
V_{OL}	Output LOW Voltage			0.5	V	$I_{OL} = 20$ mA	or $V_{IL} (Min)$		
V_{DIFF}	Input Voltage Differential	150			mV	Required for Full Output Swing			
V_{CM}	Common Mode Voltage	$V_{CC} - 2.0$		$V_{CC} - 0.5$	V				
I_{IH}	Input HIGH Current			350	μA	$V_{IN} = V_{IH} (Max)$, $D_0-D_5 = V_{BB}$, $\bar{D}_0-\bar{D}_5 = V_{IL} (Min)$			
I_{IL}	Input LOW Current	0.5			μA	$V_{IN} = V_{IL} (Min)$, $D_0-D_5 = V_{BB}$			
I_{OS}	Output Short-Circuit Current	-150		-60	mA	$V_{OUT} = GND$ (Note 4)			
I_{EE}	V_{EE} Power Supply Current	-37	-27	-17	mA	$D_0-D_5 = V_{BB}$			
I_{TTL}	V_{TTL} Power Supply Current		45	65	mA	$D_0-D_5 = V_{BB}$			
<p>Note 3: The specified limits represent the "worst case" value for the parameter. Since these values normally occur at the temperature extremes, additional noise immunity and guardbanding can be achieved by decreasing the allowable system operating ranges. Conditions for testing shown in the tables are chosen to guarantee operation under "worst case" conditions.</p> <p>Note 4: Test one output at a time.</p>									
DIP AC Electrical Characteristics									
$V_{EE} = -4.2V$ to $-5.7V$, $V_{CC} = GND$, $V_{TTL} = +4.5V$ to $+5.5V$									
Symbol	Parameter	$T_C = 0°C$		$T_C = +25°C$		$T_C = +85°C$		Units	Conditions
		Min	Max	Min	Max	Min	Max		
t_{PLH}	Propagation Delay							ns	$C_L = 15$ pF Figures 1, 2
t_{PHL}	Data to Output	0.80	3.50	0.90	3.70	1.00	4.00		
t_{PLH}	Propagation Delay							ns	$C_L = 50$ pF Figures 1, 3
t_{PHL}	Data to Output	1.60	4.30	1.70	4.50	1.80	4.80		

Commercial Version (Continued)
SOIC and PLCC AC Electrical Characteristics
 $V_{EE} = -4.2V$ to $-5.7V$, $V_{CC} = GND$, $V_{TTL} = +4.5V$ to $+5.5V$

Symbol	Parameter	$T_C = 0^\circ C$		$T_C = +25^\circ C$		$T_C = +85^\circ C$		Units	Conditions
		Min	Max	Min	Max	Min	Max		
t_{PLH} t_{PHL}	Propagation Delay Data to Output	0.80	3.30	0.90	3.50	1.00	3.80	ns	$C_L = 15$ pF Figures 1, 2
t_{PLH} t_{PHL}	Propagation Delay Data to Output	1.60	4.10	1.70	4.30	1.80	4.60	ns	$C_L = 50$ pF Figures 1, 3
t_{OSHL}	Maximum Skew Common Edge Output-to-Output Variation Data to Output Path		0.65		0.65		0.65	ns	PLCC Only (Note 5)
t_{OSLH}	Maximum Skew Common Edge Output-to-Output Variation Data to Output Path		0.65		0.65		0.65	ns	PLCC Only (Note 5)
t_{OST}	Maximum Skew Opposite Edge Output-to-Output Variation Data to Output Path		2.20		2.20		2.20	ns	PLCC Only (Note 5)
t_{PS}	Maximum Skew Pin (Signal) Transition Variation Data to Output Path		2.10		2.10		2.10	ns	PLCC Only (Note 5)

Note 5: Output-to-Output Skew is defined as the absolute value of the difference between the actual propagation delay for any outputs within the same packaged device. The specifications apply to any outputs switching in the same direction either HIGH-to-LOW (t_{OSHL}), or LOW-to-HIGH (t_{OSLH}), or in opposite directions both HL and LH (t_{OST}). Parameters t_{OST} and t_{PS} guaranteed by design.

Industrial Version

PLCC DC Electrical Characteristics

$V_{EE} = -4.2V$ to $-5.7V$, $V_{CC} = GND$, $T_C = -40^{\circ}C$ to $+85^{\circ}C$ (Note 6)

Symbol	Parameter	$T_C = -40^{\circ}C$		$T_C = 0^{\circ}C$ to $+85^{\circ}C$		Units	Conditions
		Min	Max	Min	Max		
V_{BB}	Output Reference Voltage	-1395	-1255	-1380	-1260	mV	$I_{V_{BB}} = -2.1$ mA
V_{IH}	Single-Ended Input HIGH Voltage	-1170	-870	-1165	-870	mV	Guaranteed HIGH Signal for All Inputs (with One Input Tied to V_{BB})
V_{IL}	Single-Ended Input LOW Voltage	-1830	-1480	-1830	-1475	mV	Guaranteed LOW Signal for All Inputs (with One Input Tied to V_{BB})
V_{OH}	Output HIGH Voltage	2.5		2.5		V	$I_{OH} = -2.0$ mA
V_{OL}	Output LOW Voltage		0.5		0.5	V	$I_{OL} = 20$ mA
V_{DIFF}	Input Voltage Differential	150		150		mV	Required for Full Output Swing
V_{CM}	Common Mode Voltage	$V_{CC} - 2.0$	$V_{CC} - 0.5$	$V_{CC} - 2.0$	$V_{CC} - 0.5$	V	
I_{IH}	Input HIGH Current		450		350	μA	$V_{IN} = V_{IH} (Max)$, $D_0-D_5 = V_{BB}$, $\bar{D}_0-\bar{D}_5 = V_{IL} (Min)$
I_{IL}	Input LOW Current	0.5		0.5		μA	$V_{IN} = V_{IL} (Min)$, $D_0-D_5 = V_{BB}$
I_{OS}	Output Short-Circuit Current	-150	-60	-150	-60	mA	$V_{OUT} = GND$ (Note 7)
I_{EE}	V_{EE} Power Supply Current	-37	-15	-37	-17	mA	$D_0-D_5 = V_{BB}$
I_{TTL}	V_{TTL} Power Supply Current		65		65	mA	$D_0-D_5 = V_{BB}$

Note 6: The specified limits represent the "worst case" value for the parameter. Since these values normally occur at the temperature extremes, additional noise immunity and guardbanding can be achieved by decreasing the allowable system operating ranges. Conditions for testing shown in the tables are chosen to guarantee operation under "worst case" conditions.

Note 7: Test one output at a time.

PLCC AC Electrical Characteristics

$V_{EE} = -4.2V$ to $-5.7V$, $V_{CC} = GND$, $V_{TTL} = +4.5V$ to $+5.5V$

Symbol	Parameter	$T_C = -40^{\circ}C$		$T_C = +25^{\circ}C$		$T_C = +85^{\circ}C$		Units	Conditions
		Min	Max	Min	Max	Min	Max		
t_{PLH}	Propagation Delay							ns	$C_L = 15$ pF Figures 1, 2
t_{PHL}	Data to Output	0.80	3.30	0.90	3.50	1.00	3.80		
t_{PLH}	Propagation Delay							ns	$C_L = 50$ pF Figures 1, 3
t_{PHL}	Data to Output	1.60	4.10	1.70	4.30	1.80	4.60		

Switching Waveform

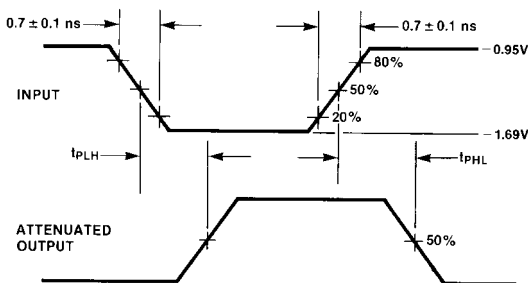
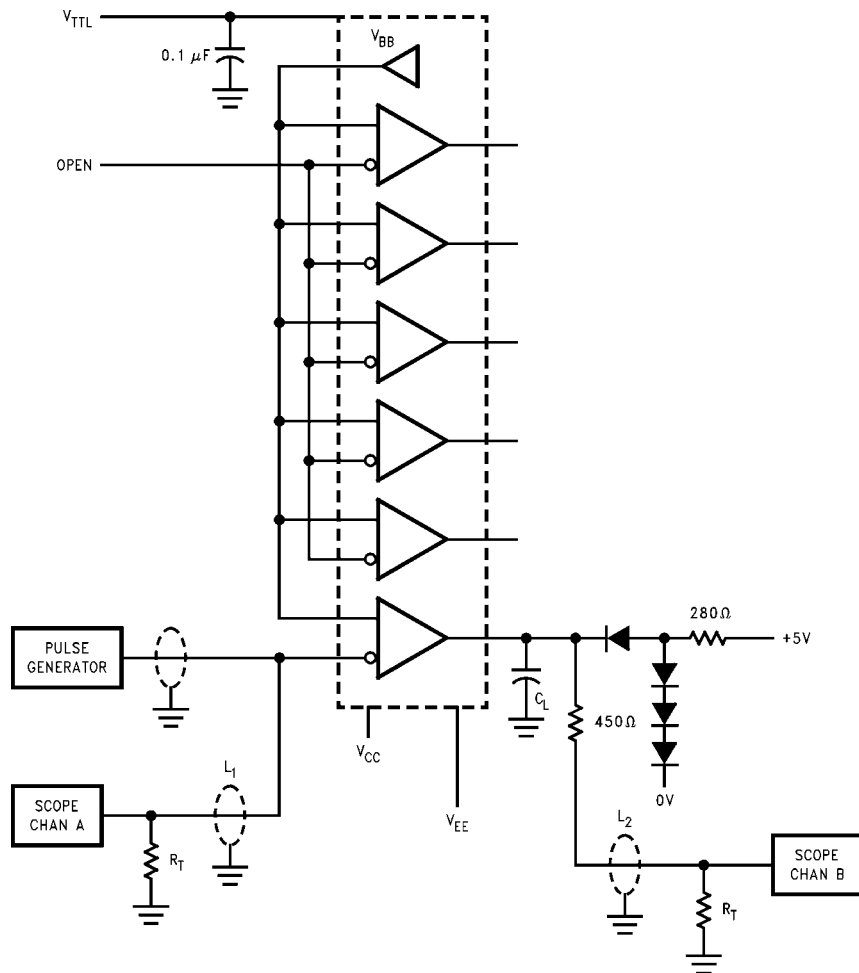

FIGURE 1. Propagation Delay

Test Circuits



- Note:**
- $V_{CC} = 0V$, $V_{EE} = -4.5V$, $V_{TTL} = +5V$
 - $L1$ and $L2$ = equal length 50Ω impedance lines
 - $R_T = 50\Omega$ terminator internal to scope
 - Decoupling $0.1 \mu F$ from GND to V_{CC} , V_{EE} and V_{TTL}
 - All unused outputs are loaded with 500Ω to GND
 - C_L = Fixture and stray capacitance = 15 pF

FIGURE 2. AC Test Circuit for 15 pF Loading

Test Circuits (Continued)

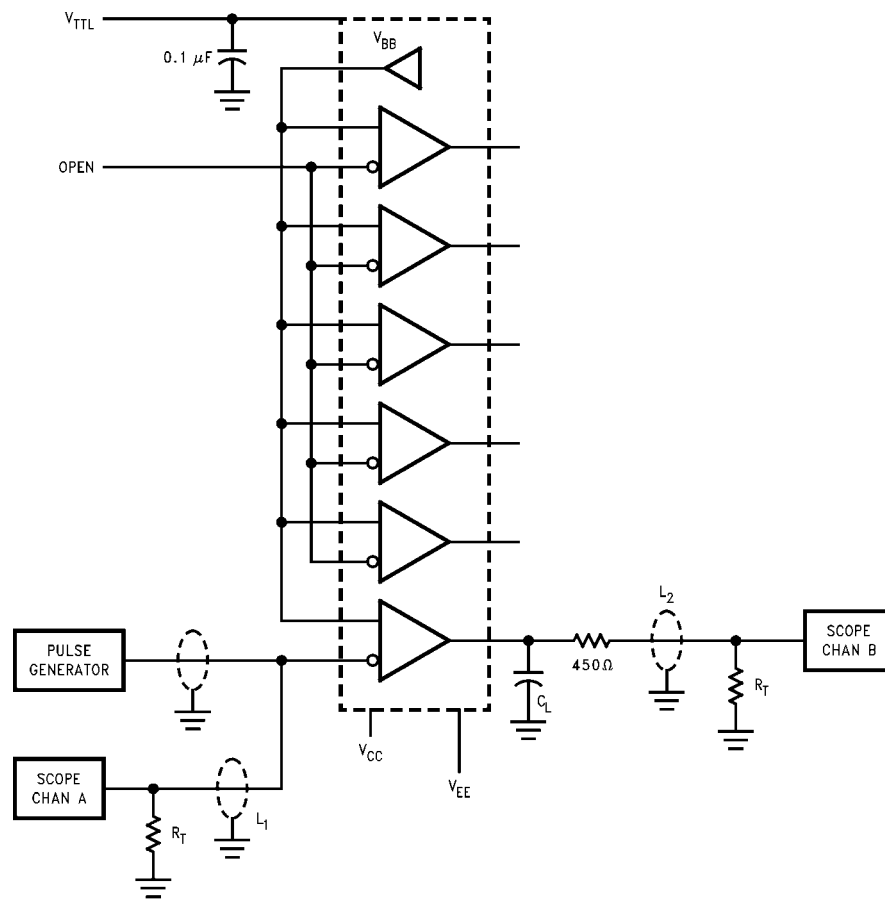

Note:

- $V_{CC} = 0V$, $V_{EE} = -4.5V$, $V_{TTL} = +5V$
- L1 and L2 = equal length 50Ω impedance lines
- $R_T = 50\Omega$ terminator internal to scope
- Decoupling 0.1 μF from GND to V_{CC} , V_{EE} and V_{TTL}
- All unused outputs are loaded with 500Ω to GND
- C_L = Fixture and stray capacitance = 50 pF

FIGURE 3. AC Test Circuit for 50 pF Loading

Physical Dimensions inches (millimeters) unless otherwise noted

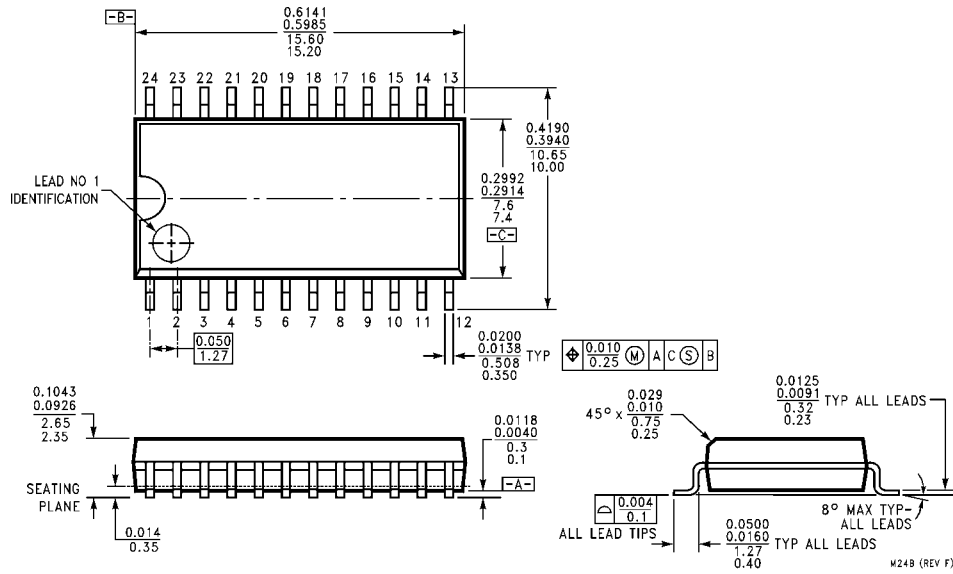

**24-Lead Small Outline Integrated Circuit (SOIC), JEDEC MS-013, 0.300 Wide
Package Number M24B**

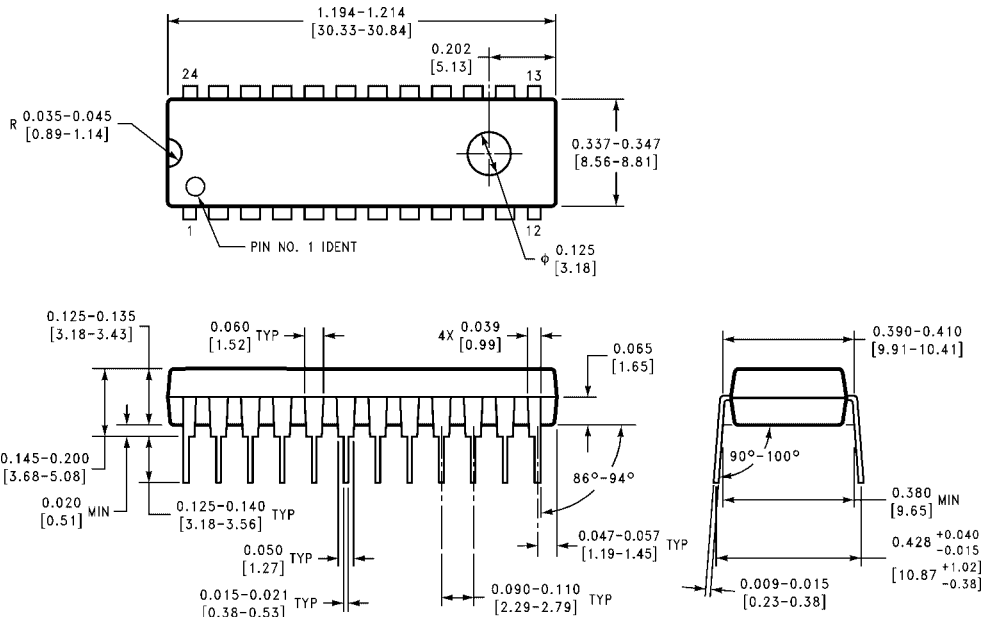

**24-Lead Plastic Dual-In-Line Package (PDIP), JEDEC MS-010, 0.400 Wide
Package Number N24E**

Physical Dimensions inches (millimeters) unless otherwise noted (Continued)

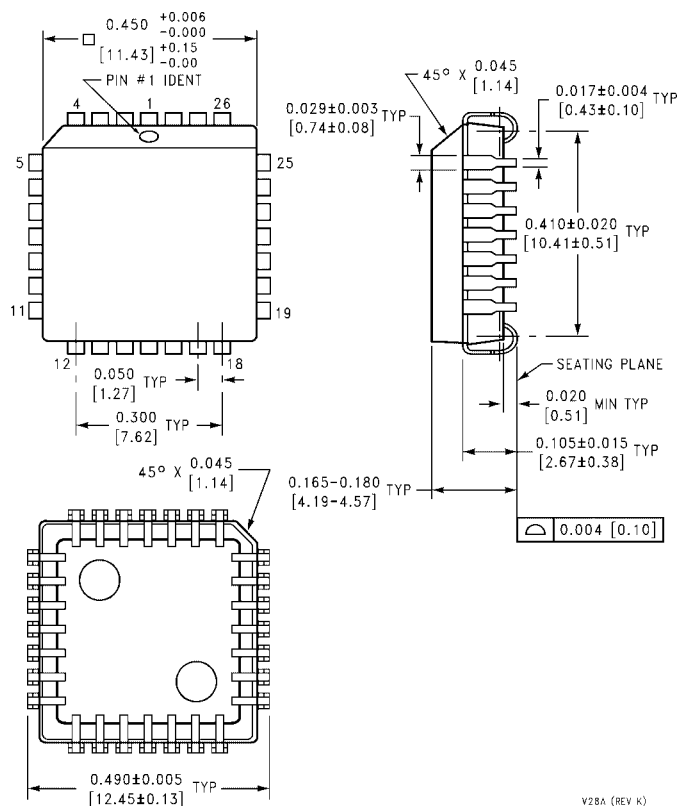

**28-Lead Plastic Lead Chip Carrier (PLCC), JEDEC MO-047, 0.450 Square
Package Number V28A**

V28A (REV K)

Fairchild does not assume any responsibility for use of any circuitry described, no circuit patent licenses are implied and Fairchild reserves the right at any time without notice to change said circuitry and specifications.

LIFE SUPPORT POLICY

FAIRCHILD'S PRODUCTS ARE NOT AUTHORIZED FOR USE AS CRITICAL COMPONENTS IN LIFE SUPPORT DEVICES OR SYSTEMS WITHOUT THE EXPRESS WRITTEN APPROVAL OF THE PRESIDENT OF FAIRCHILD SEMICONDUCTOR CORPORATION. As used herein:

1. Life support devices or systems are devices or systems which, (a) are intended for surgical implant into the body, or (b) support or sustain life, and (c) whose failure to perform when properly used in accordance with instructions for use provided in the labeling, can be reasonably expected to result in a significant injury to the user.
2. A critical component in any component of a life support device or system whose failure to perform can be reasonably expected to cause the failure of the life support device or system, or to affect its safety or effectiveness.

www.fairchildsemi.com